

InGaAs area image sensor

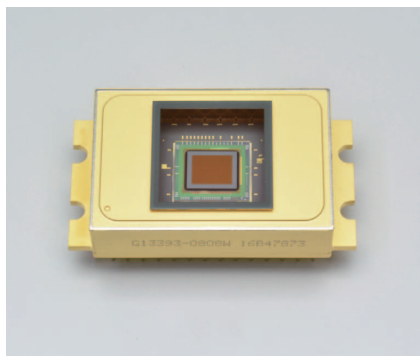

G13393-0808W

Image sensor with 320 × 256 pixels developed for two-dimensional infrared imaging

The G13393-0808W has a hybrid structure consisting of a CMOS readout circuit (ROIC: readout integrated circuit) and back-illuminated InGaAs photodiodes. Each pixel is made up of an InGaAs photodiode and a ROIC electrically connected by indium bump. The timing generator in the ROIC provides an analog video output and AD-TRIG output which are obtained by just supplying digital inputs.

The G13393-0808W has 320 × 256 pixels arrayed at a 20 μm pitch. Light incident on the InGaAs photodiodes is converted into electrical signals which are then input to the ROIC through indium bumps. Electrical signals in the ROIC are converted into voltage signals and then sequentially output from the video line by the shift register. The G13393-0808W is hermetically sealed in a metal package together with a two-stage thermoelectric cooler to deliver stable operation.

Features

- Spectral response range: 0.95 to 1.7 μm
- High sensitivity: 1 μV/e⁻
- Frame rate: 228 fps max.
- Global shutter mode
- Simple operation (built-in timing generator)
- Two-stage TE-cooled type

Applications

- Near infrared non-destructive inspection (farm produce inspection, semiconductor inspection, fill level inspection)
- Hyperspectral imaging
- Traffic monitoring

Structure

Parameter	Specification	Unit
Image size	6.40 × 5.12	mm
Cooling	Two-stage TE-cooled	-
Total number of pixels	320 × 256 (81920)	pixels
Number of effective pixels	320 × 256 (81920)	pixels
Pixel size	20 × 20	μm
Pixel pitch	20	μm
Fill factor	100	%
Package	28-pin metal (refer to dimensional outline)	-
Window material	Sapphire glass with anti-reflective coating	-

Block diagram

The series of operations of the readout circuit are described below. The integration time is equal to the low period of the master start pulse (MSP), which is a frame scan signal, and the output voltage is sampled and held simultaneously at all pixels. Then, the pixels are scanned, and the video is output.

The vertical shift register scans from top to bottom while sequentially selecting each row. The following operations ① to ③ are performed on each pixel of the selected row.

- ① Transfers the optical signal information sampled and held in each pixel to the signal processing circuit as a signal voltage, and samples and holds the signal voltage.
- ② Resets each pixel after having transferred the signal, transfers the reset signal voltage to the signal processing circuit, and samples and holds the reset signal voltage.
- ③ The horizontal shift register performs a sequential scan to output the signal voltage and reset signal voltage as serial data. The offset voltage in each pixel can be eliminated by finding a difference between the signal voltage and the reset signal voltage with a circuit outside the sensor.

Then the vertical shift register shifts by one row to select the next row and the operations ① to ③ are repeated.

When the MSP, which is a frame scan signal, goes low after the vertical shift register advances to the 256th row, the reset switches for all pixels simultaneously turn off and the next frame integration begins.

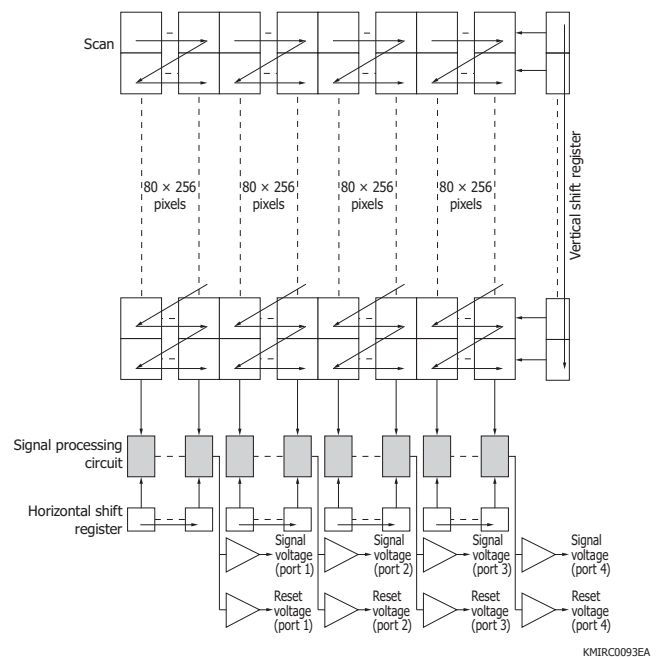

Absolute maximum ratings

Parameter	Symbol	Value	Unit
Supply voltage	V _{dd}	-0.3 to +5.5	V
Clock pulse voltage	V(MCLK)	V _{dd} + 0.5	V
Start pulse voltage	V(MSP)	V _{dd} + 0.5	V
Operating temperature*1 *2	T _{opr}	0 to +60	°C
Storage temperature*2	T _{stg}	-20 to +70	°C
Allowable TE cooler current	I _c	2.8	A
Allowable TE cooler voltage	V _c	4.0	V
Thermistor power dissipation	P _{th}	0.2	mW

*1: Chip temperature

*2: No dew condensation

When there is a temperature difference between a product and the ambient in high humidity environment, dew condensation may occur on the product surface. Dew condensation on the product may cause a deterioration of characteristics and reliability.

Note: Exceeding the absolute maximum ratings even momentarily may cause a drop in product quality. Always be sure to use the product within the absolute maximum ratings.

Electrical and optical characteristics (Ta=25 °C, Td=15 °C, Vdd=Port_sel=Mode01=5 V, Mode02=0 V, Vb1=0.5 V, PD_bias=3 V, Vref=3 V)

Parameter	Symbol	Condition	Min.	Typ.	Max.	Unit
Spectral response range	λ		-	0.95 to 1.7	-	μm
Peak sensitivity wavelength	λ_p		-	1.55	-	μm
Photosensitivity	S	$\lambda=\lambda_p$	0.7	0.8	-	A/W
Conversion efficiency	CE		-	1	-	$\mu\text{V}/e^-$
Saturation charge	Qsat		-	1100	-	ke^-
Saturation output voltage	Vsat		0.6	1.1	-	V
Photoresponse nonuniformity*3	PRNU	After subtracting dark output, Integration time=5 ms	-	± 10	± 20	%
Dark output	V _D	Integration time=10 ms	-	0.03	0.15	V
Dark current	I _D		-	0.5	2.5	pA
Dark output nonuniformity	DSNU	Integration time=10 ms	-	± 0.1	± 0.3	V
Temperature coefficient of dark output	ΔT_{Ds}		-	1.1	-	times/°C
Readout noise	N _r	Integration time=10 ms	-	500	1000	$\mu\text{V rms}$
Dynamic range	DR		-	2200	-	-
Defective pixels*4	-		-	-	0.37	%

*3: Measured at one-half of the saturation, excluding first and last pixels on each row

*4: Pixels with photoresponse nonuniformity (integration time 5 ms), dark output nonuniformity, readout noise, or dark current higher than the maximum value (Zone 1 + 2 + 3)

[Zone definitions]

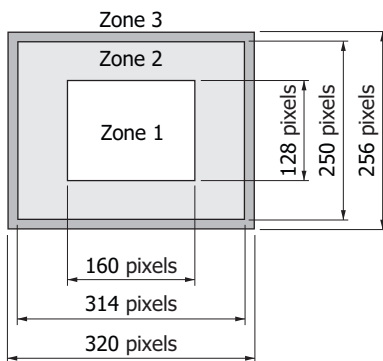

[Defective pixels in each zone]

Zone	Maximum number of defective pixels	Percentage of defective pixels
1	41	0.2%
2	116	0.2%
3	171	5.0%
1 + 2	157	0.2%
1 + 2 + 3	303	0.37%

[Consecutive defective pixels]

The number of consecutive adjacent defect pixels is less than 16.

KMIRC0094EA

Electrical characteristics (Ta=25 °C, Td=15 °C, Vdd=Port_sel=Mode01=5 V, Mode02=0 V, Vb1=0.5 V, PD_bias=3 V, Vref=3 V)

Parameter	Symbol	Min.	Typ.	Max.	Unit
Supply current*5	I _{dd}	-	50	100	mA
Element bias current	I(PD_bias)	-	-	1	mA

Equivalent circuit

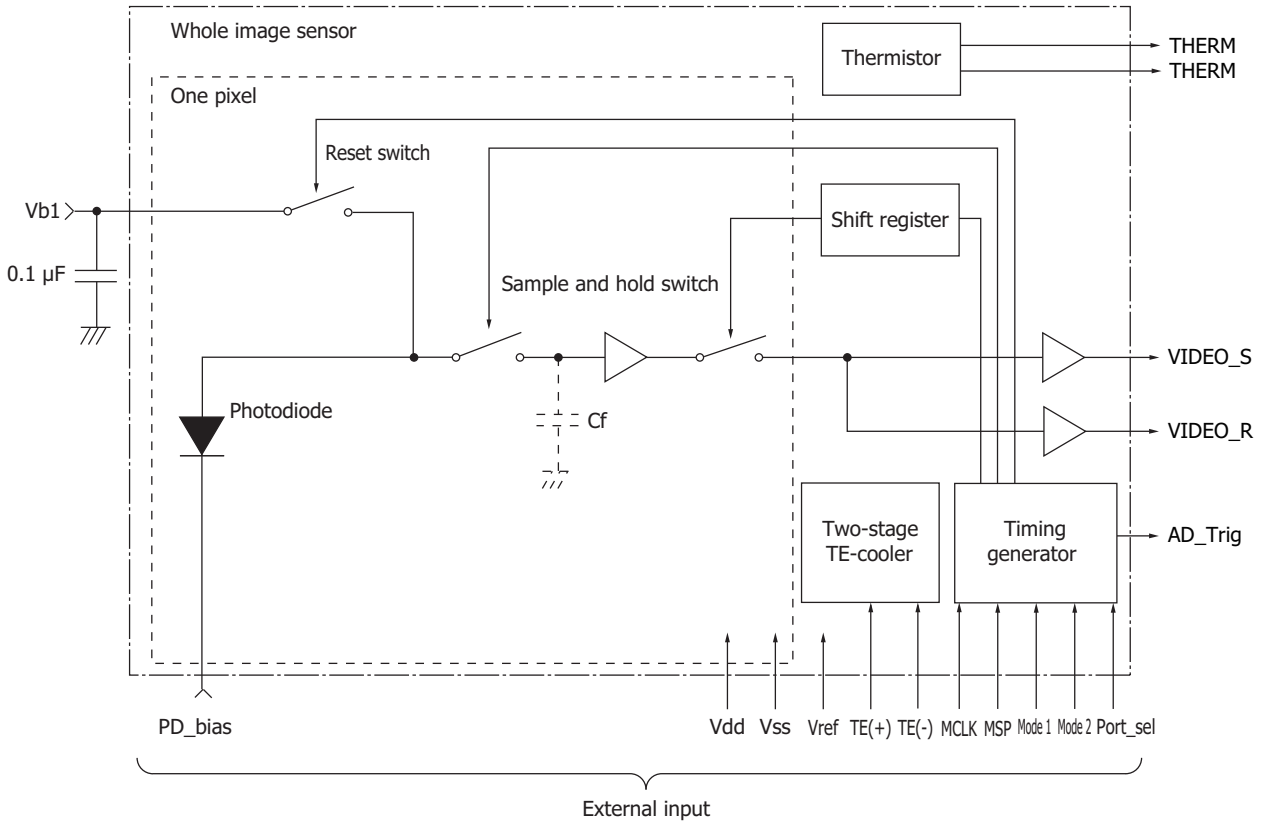

KMIRC0072ED

Connection example

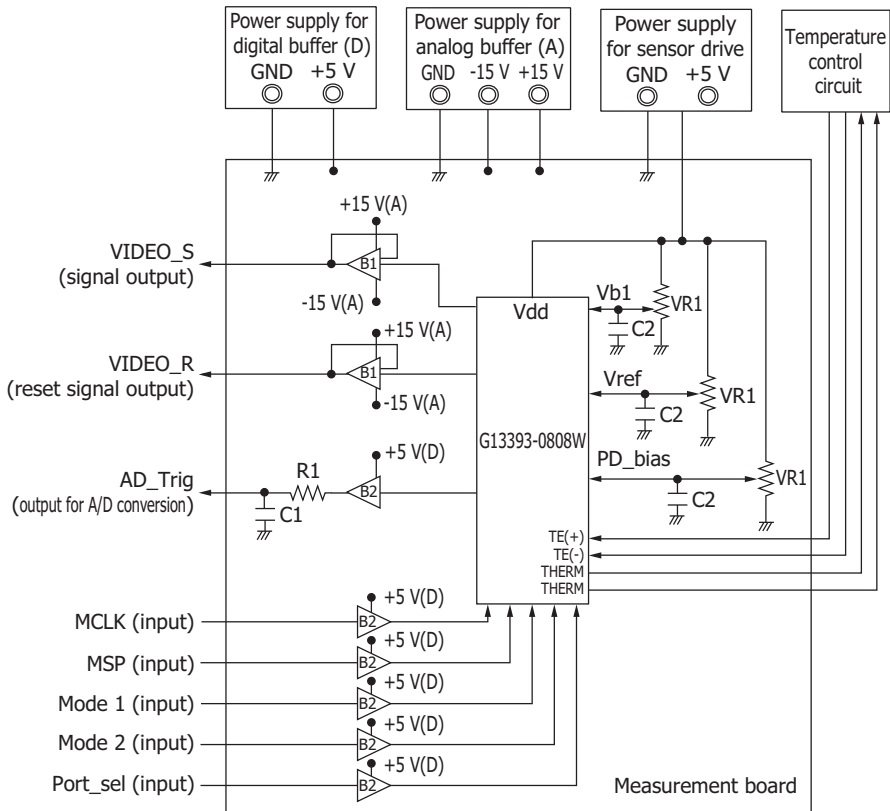

(Reference) Parameter values (Reference) Buffer

Symbol	Value
R1	10 Ω
VR1	10 kΩ
C1	330 pF
C2	0.1 μF

Symbol	IC
B1	AD847
B2	TC74HCT541

KMIRC0095EA

Timing chart

The video output from a single pixel is equal to 4 MCLK (master clock) pulses. The MSP (master start pulse) is a signal for setting the integration time, so making the low (0 V) period of the MSP longer will extend the integration time. The MSP also functions as a signal that triggers each control signal to perform frame scan. When the MSP goes from low (0 V) to high (5 V), each control signal starts on the falling edge of the MCLK and frame scan is performed during the high period of the MSP. The low (0 V) period of the MSP serves as the integration time. The timing charts when operated at a MCLK frequency of 25 MHz are shown below.

■ Number of readout ports: 4

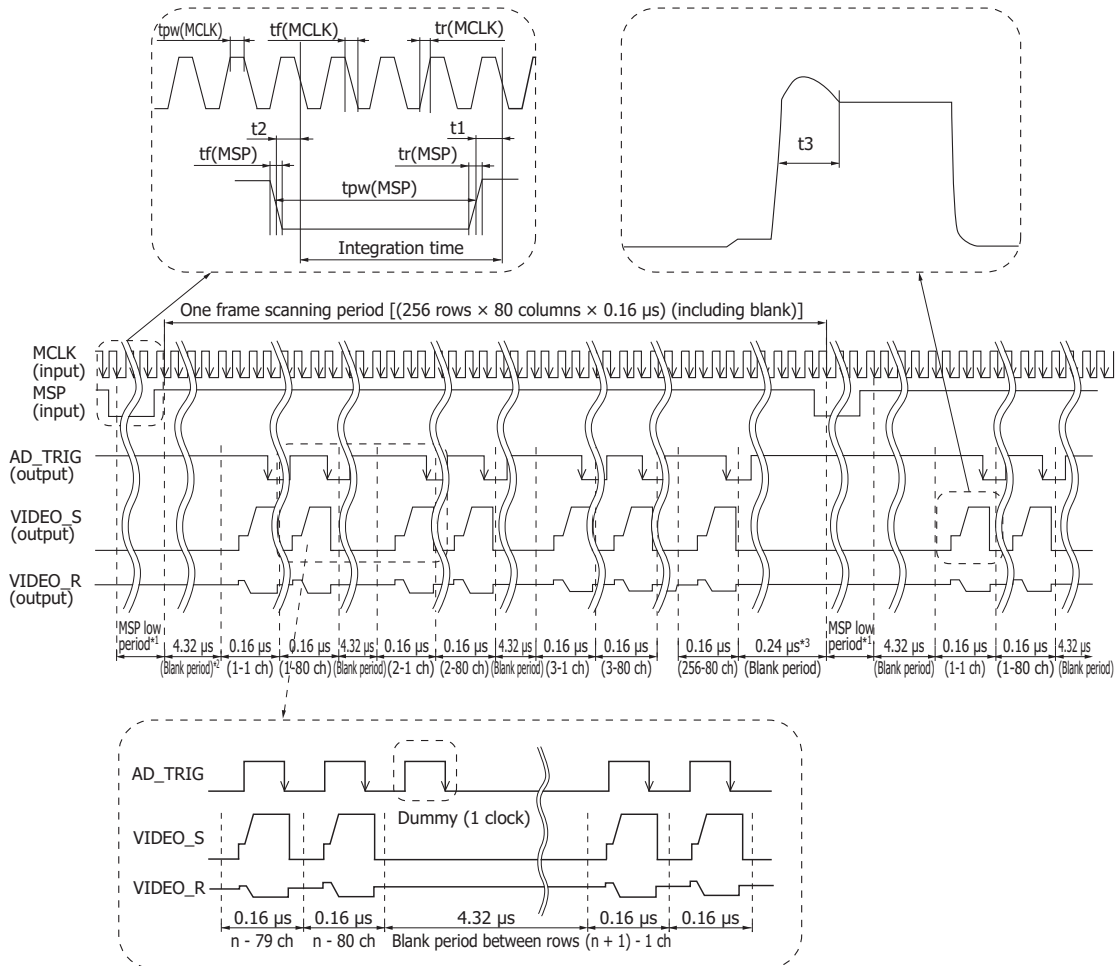

*1: The minimum number of MCLK pulses during the MSP low period is 25. The integration time can be changed by adjusting the MSP low period.
 Integration time = MSP low period
 *2: There is a blank of 4.32 μs between each row.
 *3: The blank period after scanning the last channel is 0.24 μs.

KMIRC0096EA

Parameter	Symbol	Min.	Typ.	Max.	Unit
Clock pulse rise/fall times	$tr(MCLK)$	0	10	12	ns
	$tf(MCLK)$				
Clock pulse width	$tpw(MCLK)$	10	-	-	ns
Start pulse rise/fall times	$tr(MSP)$	0	10	12	ns
	$tf(MSP)$				
Start pulse width	$tpw(MSP)$	0.001	-	10	ms
Reset (rise) timing*5	t1	10	-	-	ns
Reset (fall) timing*5	t2	10	-	-	ns
Output settling time	t3	-	-	50	ns

*5: Setting these timings shorter than the minimum value may delay the operation by one MCLK pulse and cause malfunction.

Recommended drive conditions (Ta=25 °C)

Parameter	Symbol	Min.	Typ.	Max.	Unit
Supply voltage	Vdd	4.9	5	5.1	V
Ground	Vss	-	0	-	V
Element bias current	V(PD_bias)	2.9	3.0	3.1	V
Pixel reset voltage	Vb1	0.4	0.5	0.6	V
Video line reset voltage	Vref	2.9	3.0	3.1	V
Clock frequency	f	-	-	25	MHz
Clock pulse voltage	High level	Vdd - 0.5	Vdd	Vdd + 0.5	V
	Low level	0	0	0.5	
Start pulse voltage	High level	Vdd - 0.5	Vdd	Vdd + 0.5	V
	Low level	0	0	0.5	
Video output voltage (VIDEO_S)	High level	Vsh	4.0	4.1	V
	Low level	Vsl	2.9	3.0	
Video output voltage	VIDEO_R	2.8	2.9	3.0	V
Video data rate	DR	-	f/4	-	MHz
Frame rate*6	FV	-	-	228	fps

*6: Frame rate=1/(MSP low period + Readout time)

Readout time=(Video data rate × Number of pixels) + (Blank period between rows × Number of rows) + Blank period between frames
MSP low period=1 μs min.

Readout time={0.16 μs × 80 columns × 256 rows} + (4.32 μs × 256 rows) + 0.24 μs=4382.96 μs

Frame rate=1/(1 μs + 4382.96 μs)=228.1 fps

Operation mode selection

Terminal name	Pin no.	Input	Description
Port_sel	24	High=5 V (Vdd)	To enable the setting for reading from all ports, apply a fixed voltage of High=5 V (Vdd).
Mode2	25	Low=0 V (Vss)	To operate the sensor in global shutter mode, apply the fixed voltage indicated on the left.
Mode1	27	High=5 V (Vdd)	

Spectral response

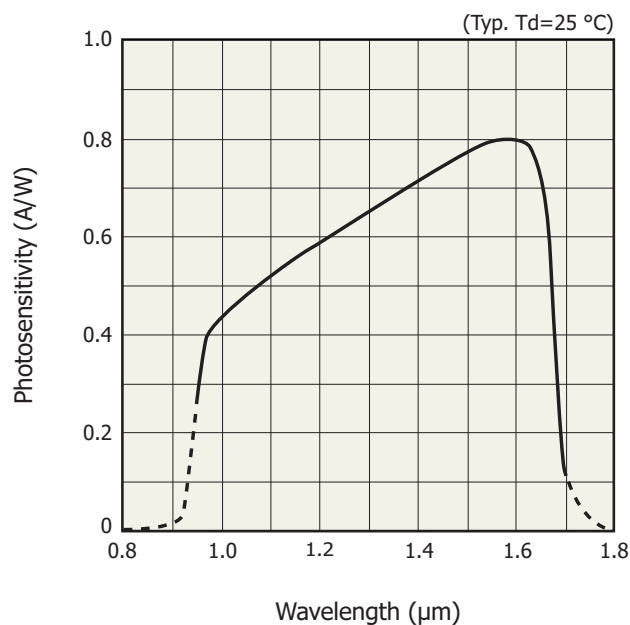

Photosensitivity temperature characteristics

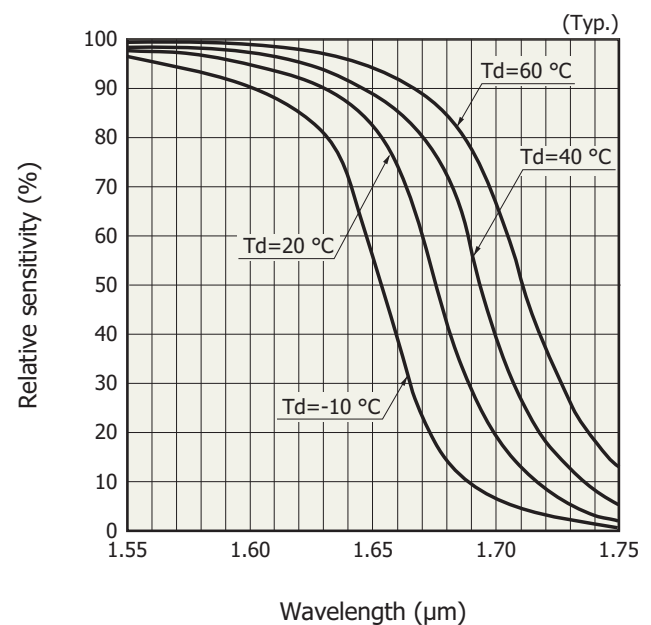

Specifications of built-in TE-cooler and thermistor

Parameter	Symbol	Condition	Min.	Typ.	Max.	Unit
Internal resistance	Rint	Ta=25 °C	0.75	0.9	1.05	Ω
Maximum heat absorption of built-in TE-cooler*7 *8	Qmax		-	8.4	-	W
Thermistor resistance	Rth		8.2	9	9.8	kΩ

*7: This is a theoretical heat absorption level that offsets the temperature difference in the thermoelectric cooler when the maximum current is supplied to the sensor.

*8: Heat absorption at Tc=Th

Tc: Temperature on the cooling side of TE-cooler

Th: Temperature on the heat dissipating side of TE-cooler.

Thermistor temperature characteristics*9

Cooling characteristics of TE-cooler*9

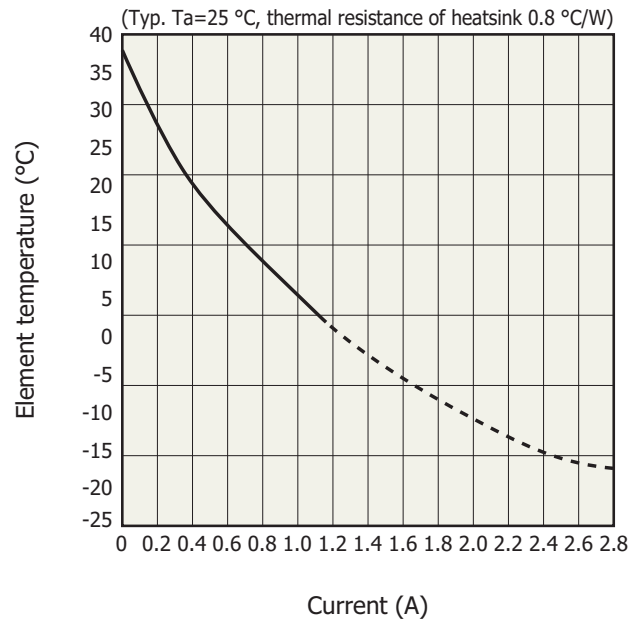
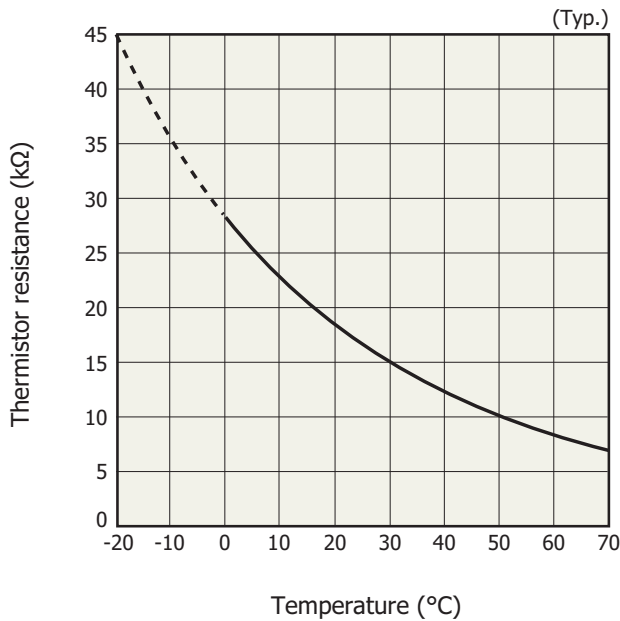

KMIRB0067EB

KMIRB0088EB

There is the following relation between the thermistor resistance and temperature (°C).

$$R1 = R2 \times \exp B \{1/(T1 + 273.15) - 1/(T2 + 273.15)\}$$

R1: resistance at T1 (°C)

R2: resistance at T2 (°C)

B: B constant (B=3410 K ± 2%)

Thermistor resistance=9 kΩ (at 25 °C)

*9: The range outside the operating temperature range (0 to +60 °C) is indicated with a broken line.

Current vs. voltage characteristics of TE-cooler*9

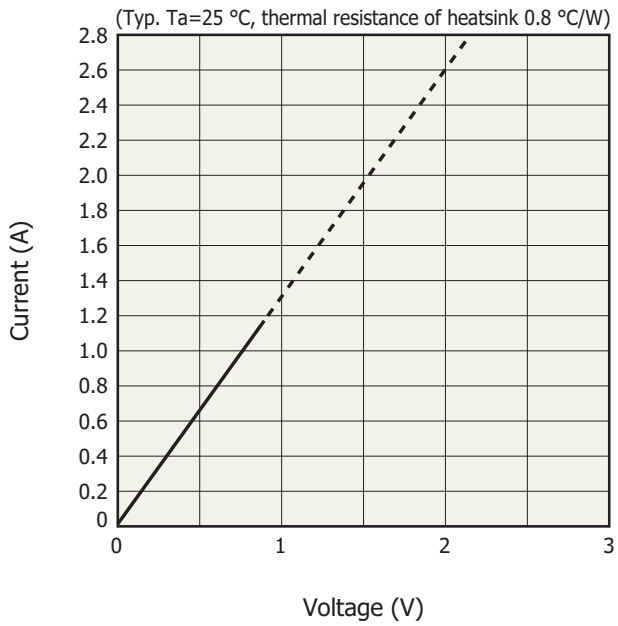

KMIRB0089EB

*9: The range outside the operating temperature range (0 to $+60\text{ }^\circ\text{C}$) is indicated with a broken line.

Dimensional outline (unit: mm)

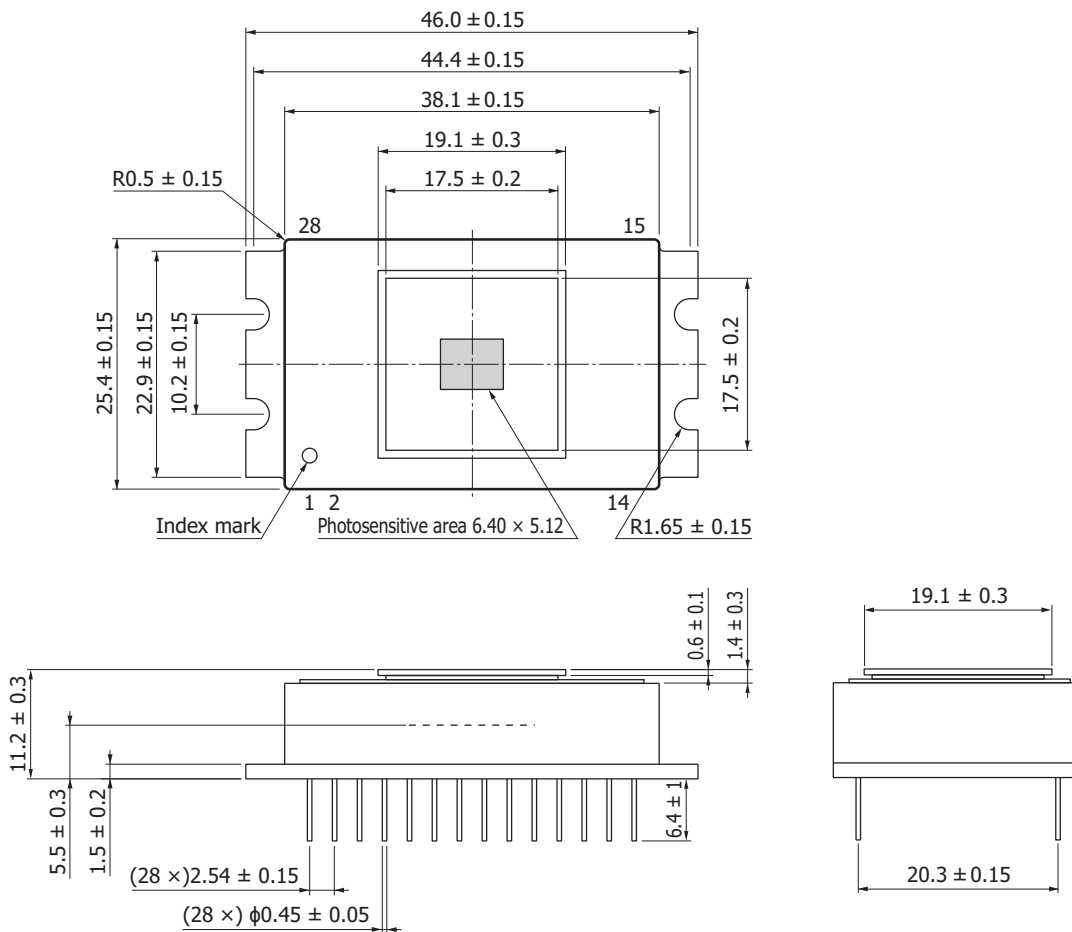

KMIRA0034EA

Pin connections

Pin no.	Name	Input/output	Function	Remarks
1	PD_bias	Input	Photodiode bias voltage	3.0 V
2	Vb1	Input	Pixel bias voltage	0.5 V
3	TE(+)	Input	Thermoelectric cooler (+)	
4	NC	-	-	
5	Vref	Input	Video reference voltage	3.0 V
6	VIDEO-S1	Output	Video output after integration (port 1)	2.9 to 4.0 V typ.
7	VIDEO-R1	Output	Video output after reset (port 1)	2.9 V typ.
8	Vss	Input	0 V ground	0 V
9	VIDEO-S2	Output	Video output after integration (port 2)	2.9 to 4.0 V typ.
10	VIDEO-R2	Output	Video output after reset (port 2)	2.9 V typ.
11	VIDEO-S3	Output	Video output after integration (port 3)	2.9 to 4.0 V typ.
12	VIDEO-R3	Output	Video output after reset (port 3)	2.9 V typ.
13	VIDEO-S4	Output	Video output after integration (port 4)	2.9 to 4.0 V typ.
14	VIDEO-R4	Output	Video output after reset (port 4)	2.9 V typ.
15	Vdd	Input	+5 V power supply	5 V
16	THERM	Output	Thermistor	
17	THERM	Output	Thermistor	
18	D_Vdd	Input	+5 V power supply (digital)	5 V
19	NC	-	-	
20	AD_Trig	Output	A/D sampling signal	Synchronized with falling edge
21	MSP	Input	Frame scan start pulse	
22	MCLK	Input	Control pulse for timing generator	Synchronized with falling edge
23	D_Vdd	Input	+5 V power supply (digital)	5 V
24	Port_sel	Input	Readout port	Fixed at 5 V
25	Mode2	Input	Operation mode 2	Fixed at 0 V
26	TE(-)	Input	Thermoelectric cooler (-)	
27	Mode1	Input	Operation mode 1	Fixed at 5 V
28	NC	-	-	Do not ground.

■ Precautions

(1) Electrostatic countermeasures

This device has a built-in protection circuit against static electrical charges. However, to prevent destroying the device with electrostatic charges, take countermeasures such as grounding yourself, the workbench and tools to prevent static discharges. Also protect this device from surge voltages which might be caused by peripheral equipment.

(2) Incident window

If there is dust or stain on the light incident window, it will show up as black blemishes on the image. When cleaning, avoid rubbing the window surface with dry cloth, dry cotton swab or the like, since doing so may generate static electricity. Use soft cloth, paper or a cotton swab moistened with alcohol to wipe dust and stain off the window surface. Then blow compressed air onto the window surface so that no spot or stain remains.

(3) Soldering

To prevent damaging the device during soldering, take precautions to prevent excessive soldering temperatures and times. Soldering should be performed within 10 seconds at a soldering temperature below 260 °C.

(4) Operating and storage environments

Handle the device within the temperature range specified in the absolute maximum ratings. Operating or storing the device at an excessively high temperature and humidity may cause variations in performance characteristics and must be avoided.

■ Related information

www.hamamatsu.com/sp/ssd/doc_en.html

- Precautions
- Disclaimer
- Image sensors

Information described in this material is current as of July 2016.

Product specifications are subject to change without prior notice due to improvements or other reasons. This document has been carefully prepared and the information contained is believed to be accurate. In rare cases, however, there may be inaccuracies such as text errors. Before using these products, always contact us for the delivery specification sheet to check the latest specifications.

The product warranty is valid for one year after delivery and is limited to product repair or replacement for defects discovered and reported to us within that one year period. However, even if within the warranty period we accept absolutely no liability for any loss caused by natural disasters or improper product use. Copying or reprinting the contents described in this material in whole or in part is prohibited without our prior permission.

HAMAMATSU

www.hamamatsu.com

HAMAMATSU PHOTONICS K.K., Solid State Division

1126-1 Ichino-cho, Higashi-ku, Hamamatsu City, 435-8558 Japan, Telephone: (81) 53-434-3311, Fax: (81) 53-434-5184

U.S.A.: Hamamatsu Corporation: 360 Foothill Road, Bridgewater, N.J. 08807, U.S.A., Telephone: (1) 908-231-0960, Fax: (1) 908-231-1218

Germany: Hamamatsu Photonics Deutschland GmbH: Arzbergerstr. 10, D-82211 Herrsching am Ammersee, Germany, Telephone: (49) 8152-375-0, Fax: (49) 8152-265-8

France: Hamamatsu Photonics France S.A.R.L.: 19, Rue du Saule Trapu, Parc du Moulin de Massy, 91882 Massy Cedex, France, Telephone: 33-(1) 69 53 71 00, Fax: 33-(1) 69 53 71 10

United Kingdom: Hamamatsu Photonics UK Limited: 2 Howard Court, 10 Tewin Road, Welwyn Garden City, Hertfordshire AL7 1BW, United Kingdom, Telephone: (44) 1707-294888, Fax: (44) 1707-325777

North Europe: Hamamatsu Photonics Norden AB: Torshamnsgatan 35 16440 Kista, Sweden, Telephone: (46) 8-509-031-00, Fax: (46) 8-509-031-01

Italy: Hamamatsu Photonics Italia S.r.l.: Strada della Moia, 1 int. 6, 20020 Arese (Milano), Italy, Telephone: (39) 02-93581733, Fax: (39) 02-93581741

China: Hamamatsu Photonics (China) Co., Ltd.: B1201, Jiaming Center, No.27 Dongsanhuan Beilu, Chaoyang District, Beijing 100020, China, Telephone: (86) 10-6586-6006, Fax: (86) 10-6586-2866