

Compact Side-on PMT

Photosensor Modules H9306/H9307 Series



The H9306/H9307 series photosensor modules incorporate a 13-mm (1/2") diameter side-on photomultiplier tube, a high-voltage power supply circuit and a low noise amplifier. Two types of amplifiers are available with a current-to-voltage conversion factor of 1 V/μA or 0.1 V/μA and a frequency bandwidth of 20 kHz or 200 kHz. The H9306/H9307 series uses a Cockcroft-Walton circuit with low power consumption.

Five types of photomultiplier tubes are provided as standard lineups to meet various needs for spectral response range. Flexible cables are used for easy installation equipment.

Product Variations

Type No.					Current-to-Voltage Conversion Factor*	Frequency Bandwidth*	Features
185 nm to 750 nm	185 nm to 900 nm	185 nm to 900 nm	185 nm to 830 nm	185 nm to 650 nm			
H9306-01	H9306-02	H9306-03	H9306-04	H9306-05	1 V/μA	DC to 20 kHz	Low power consumption
H9307-01	H9307-02	H9307-03	H9307-04	H9307-05	0.1 V/μA	DC to 200 kHz	

* The amplifier specification can be changed upon request. Feel free to contact our sales office.

This product can't be used at vacuum environment or reduced pressure environment. Please pay attention when the H9306 series/H9307 series is used for measuring the light below 190 nm.

Specifications

(at +25 °C)

Parameter		H9306 / H9307 Series					Unit	
Suffix		-01	-02	-03	-04	-05	—	
Input Voltage		±11.5 to ±15.5					V	
Max. Input Voltage		±18					V	
Max. Input Current		+9 / -1 (H9306), +15 / -8 (H9307)					mA	
Max. Control Voltage		+1.2 (Input Impedance: 1 MΩ)					V	
Recommended Control Voltage Adjustment Range		+0.25 to +1.0					V	
Effective Area		3.7 × 13.0					mm	
Peak Sensitivity Wavelength		420	400	450	530	340	nm	
Cathode	Luminous Sensitivity	Min.	80	200	350	140	20	μA/lm
		Typ.	120	300	500	200	40	
	Blue Sensitivity Index (CS 5-58)	Typ.	10	—	—	—	5	—
	Red/White Ratio	Typ.	—	0.3	0.4	0.15	—	—
Radiant Sensitivity *1		Typ.	90	77	105	70	48	mA/W
H9306 Series (with internal 20 kHz amp)								
Anode	Luminous Sensitivity *2	Min.	1.0 × 10 ⁸	4.0 × 10 ⁸	1.0 × 10 ⁹	3.0 × 10 ⁸	5.0 × 10 ⁷	V/lm
		Typ.	7.0 × 10 ⁸	1.2 × 10 ⁹	2.0 × 10 ⁹	7.0 × 10 ⁸	3.0 × 10 ⁸	
	Radiant Sensitivity *1 *2	Typ.	520	310	420	250	360	V/nW
	Voltage Output Depending on PMT Dark Current *2 *3 *4	Typ.	1	1	2	0.1	0.5	mV
Max.		10	10	10	1	5		
Max. Output Signal Voltage *5		+10 (Load resistance 10 kΩ)					V	
Current-to-Voltage Conversion Factor		1					V/μA	
H9307 Series (with internal 200 kHz amp)								
Anode	Luminous Sensitivity *2	Min.	1.0 × 10 ⁷	4.0 × 10 ⁷	1.0 × 10 ⁸	3.0 × 10 ⁷	5.0 × 10 ⁶	V/lm
		Typ.	7.0 × 10 ⁷	1.2 × 10 ⁸	2.0 × 10 ⁸	7.0 × 10 ⁷	3.0 × 10 ⁷	
	Radiant Sensitivity *1 *2	Typ.	52	31	42	25	36	V/nW
	Voltage Output Depending on PMT Dark Current *2 *3 *4	Typ.	0.1	0.1	0.2	0.01	0.05	mV
Max.		1	1	1	0.1	0.5		
Max. Output Signal Voltage *5		+1 (Load resistance 10 kΩ)					V	
Current-to-Voltage Conversion Factor		0.1					V/μA	
H9306 / H9307 Series								
Offset Voltage		Typ.	±3					mV
Ripple Noise *2 *6 (peak to peak)		Max.	0.8					mV
Settling Time *7		Max.	10					s
Operating Ambient Temperature *8							+5 to +50	°C
Storage Temperature *8							-20 to +50	°C
Weight							110	g

*1: Measured at the peak sensitivity wavelength *2: Control voltage = +1.0 V *3: After 30 minutes storage in darkness *4: Output of anode dark current

*5: At ±15 V input voltage *6: Cable RG-174/U, Cable length 450 mm, Load resistance = 1 MΩ, Load capacitance = 22 pF

*7: The time required for the output to reach a stable level following a change in the control voltage from +1.0 V to +0.5 V. *8: No condensation

Voltage Output Type Photosensor Modules

Characteristics (Anode radiant sensitivity, PMT gain)

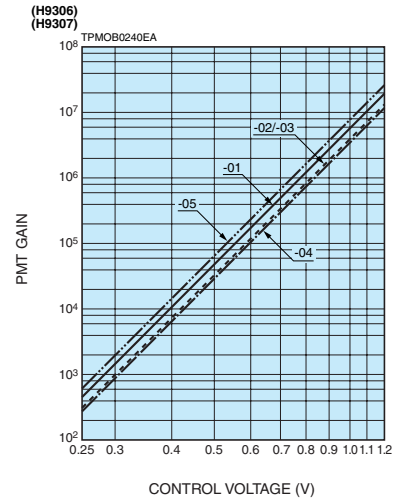
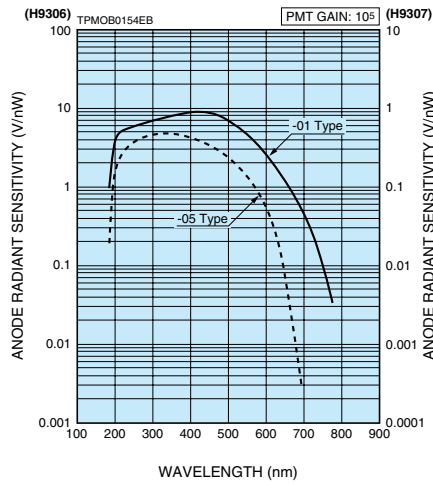
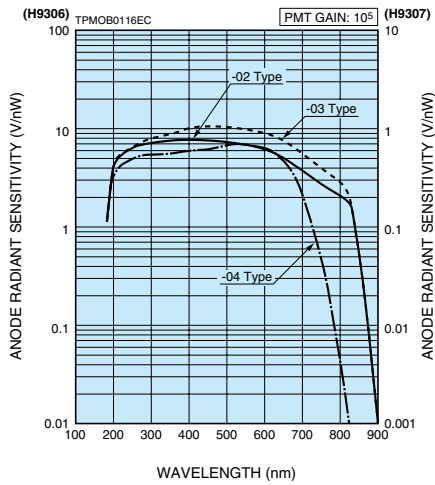

Sensitivity Adjustment Method

VOLTAGE PROGRAMMING

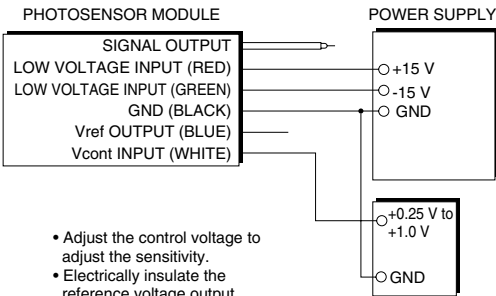

RESISTANCE PROGRAMMING

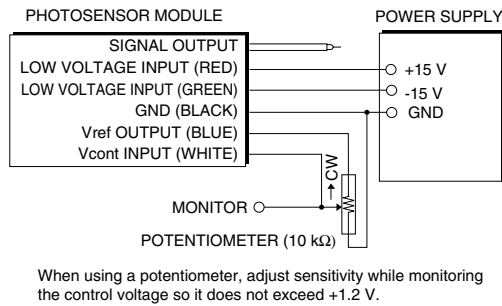

TPMOC0147ED

Dimensional Outlines (Unit: mm)

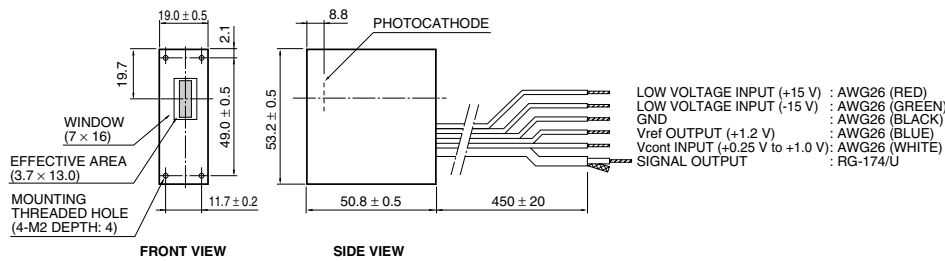

TPMOA0013EH

DETAILS OF INPUT WINDOW

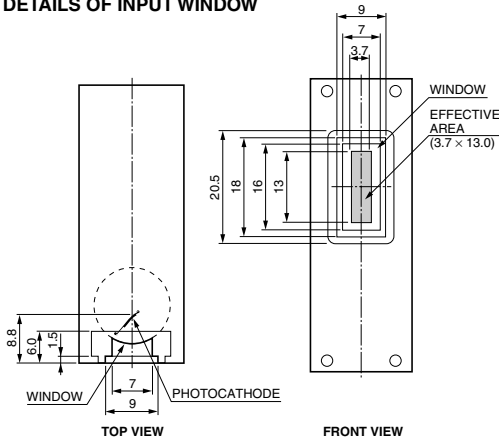

TPMOA0018EE