

Metal, ceramic, plastic package products

This document describes general precautions for using HAMAMATSU opto-semiconductors of metal, ceramic, and plastic packages (hereafter called "the product"). For precautions on handling image sensors, unsealed products (opto-semiconductors whose chip is exposed), refer to precautions of "image sensors", "unsealed products" available from HAMAMATSU respectively.

If the product comes with special precautions on the delivery specification sheet, then be sure to strictly comply with those instructions.

1. Handling

(1) Dust, contamination and scratch countermeasures

Dirt, stains, or scratches on the product may cause poor electrical and optical characteristics, so use caution on the following points:

- Perform work in a clean location.
- Dropping the product or causing strong friction to the window material may damage the window, so use plenty of caution when handling.
- Using tweezers or gloves is recommended when touching the product. Be especially careful not to touch the window with bare hands. Dirt or stains on the window may cause a drop in light transmittance through the window. In the case of ultraviolet light detection, oil from the fingers can cause a 30% drop in sensitivity. Moreover, touching the leads with bare hands may cause leakage between terminals or plating corrosion, or problems with solder wettability.
- Do not allow sharp or hard objects to come in contact with the window to prevent it from being scratched. Resin sealed (potting or coating) types, plastic packages, and types with an anti-reflection coated window are vulnerable to scratches, so handle them carefully. If very small light spots are detected, then scratches on the window may be a problem.
- Take precautions to protect the window from contamination or scratches when packing or shipping equipment in which the product is installed.

(2) Removing contamination

- Use air blow to remove dust adhering to the window. When handling an electrostatic sensitive devices, use an ionizer to remove static electricity.
- If oil or grease adheres to the window, then gently wipe it away with cotton swabs, etc. moistened with ethyl alcohol while taking care not to scratch the window. Strongly rubbing or rubbing the same section over and over might cause poor electrical and optical characteristics, or a loss of device reliability.
- When cleaning the window surface, do not rub it with dry cloth or cotton swab. Doing so may generate static electricity and lead to malfunctions.

(3) Cleaning

Avoid use of solvents as much as possible for cleaning. If such use is unavoidable, then keep the following points in mind:

- Use alcohol solvents such as ethyl alcohol. Some solvents may damage plastic packages and cause package swelling.
- Before actual cleaning, check for any problems by testing out the cleaning methods in advance.
- Ultrasonic and steam cleaning may cause fatal damage to the product, so do not use such methods. Soak washing is recommended.
- If mounting components on a printed circuit board using no-clean solder, do not try to clean away the flux. Cleaning away the flux may cause problems such as electrical leaks between terminals and operating failures.

[Figure 1] Do not damage window.

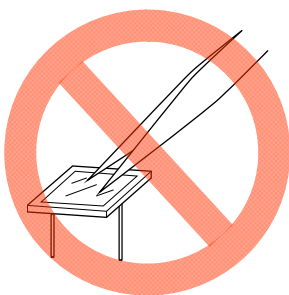

KPDC0012EA

[Figure 2] Remove dirt from the window by gently wiping with a cotton swab, etc. moistened with ethyl alcohol.

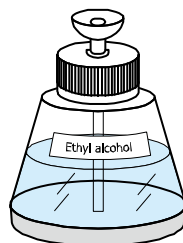
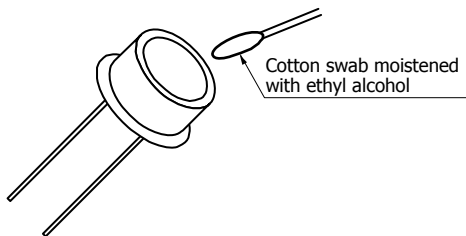

KIRD0027EA

(4) Handling component leads

- During the design stage, make sure the lead insertion hole spacing on the printed circuit board match the lead spacing of the product. Do not attempt to forcibly insert the leads into the holes if the insertion hole spacing does not match the product lead spacing.
- Do lead forming and trimming before starting soldering.
- Clamp the root of the lead before forming and trimming the lead and be sure not to apply mechanical stress to the leads within the package during these tasks. Forming the leads from their roots may cause package cracks and other problems.
- If cutting the leads after soldering is unavoidable, then do so after the soldered section has returned to normal temperature.

[Figure. 3] Lead forming

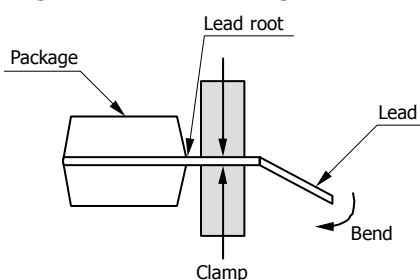

KOTH0034EA

(5) Ultraviolet light and X-ray irradiation

Long-term exposure to UV or X-ray irradiation will cause product characteristics to deteriorate. Avoid exposing the product to any unnecessary UV or X-ray irradiation. The product usage environment may require countermeasures to block unnecessary UV or X-rays. Please avoid exposing the bonding sections of the ceramic base and glass to UV light.

2. Storage

Carefully observe the product storage conditions listed in the delivery specification sheet. Do not let the product get wet or be exposed to direct sunlight, harmful gases or dust. Also avoid storing it in locations where sudden temperature changes may occur.

(1) Products packed in conductive moisture-proof bags

- To prevent oxidation or contamination on the leads and moisture absorption by the package, do not open the conductive moisture-proof bag until just before product use. Even if still packed in the moisture-proof bag, do not let the bag get wet or be exposed to direct sunlight, harmful gases or dust, or do not store it in locations where sudden temperature changes may occur. Also avoid humidity rise which may occur such as by turning off the night-time air conditioning.
- Do not lay a heavy object or load on the product or the bag. Also avoid stacking the products or bags when storing them.
- If storing the product in another case, then use a container not easily charged with static electricity. If the product is an electrostatic sensitive device, then place it in a conductive case.
- Placing the product in an unsatisfactory environment (exceeding conditions in Table 1) may cause poor solderability, rust on product leads, or a drop in electrical characteristics. If there are storage conditions listed on the datasheet or delivery specification sheet, then be sure to comply with them.
- If there is a problem with the sealing of the moisture-proof packing, then the silica gel color will change from navy blue to red due to moisture absorption. So check for color change of the silica gel when opening. If you find this abnormality, then please contact us for assistance.

[Table 1] Storage conditions (products shipped sealed in conductive moisture-proof bags)

Product	Storage conditions	Cautions
Unopened product	Temperature: 15 °C to 35 °C Humidity: 45% to 75% Period: within 12 months	A sharp item coming in contact with the moisture-proof bag might open a hole in it so use caution. After opening, we recommend storage in a low-humidity desiccator.
Opened product	Temperature: 15 °C to 35 °C Storage in a low-humidity desiccator (no condensation) Period: within 3 months	

(3) Tape packing products

- Tape unwound from a reel must not be left in that state for long periods.
- Do not bend the tape more than necessary.

3. Soldering

The correct soldering time and temperature differ depending on the type of package. See the recommended soldering condition examples [Table 2] for soldering time and temperature. If soldering conditions are listed in the datasheet or delivery specification sheet, then please comply with those conditions.

[Table 2] Recommended soldering condition examples

Package	Soldering temperature	Soldering time	Remark
Metal	260 °C or less	Within 10 seconds	
Ceramic	260 °C or less	Within 5 seconds	Solder the leads at a point at least 2 mm away from the package body. [Figure 5]
Plastic	230 °C or less	Within 5 seconds	Solder the leads at a point at least 1 mm away from the package body.

(1) Points requiring special caution

- Take adequate care to make sure that the soldering iron tip temperature and the soldering time are correct.
- Do not attempt soldering at high temperatures or long periods.
- Take measures to prevent solder or flux from flying outward and sticking to the window, contaminating it.

(2) Flux

Use non-cleaning solder or rosin type flux. Using flux with relatively strong acid or alkali levels or inorganic flux may cause corrosion on the leads.

(3) When using a soldering iron

- To prevent effects from electrostatic charges, use a grounded soldering iron whose insulation resistance is 10 MΩ or more.
- Set the soldering iron tip temperature by referring to the recommended soldering condition examples [Table 2]. If you cannot provide these conditions, then grip the root of the lead you are soldering with tweezers or a similar tool to prevent heat from conducting to the product package [Figure 4].

- Do not let the soldering iron directly contact the package section of the product. Direct contact with the soldering iron may cause mechanical or optical damage.
- Do the soldering so that no stress is applied to the package section of the product. Soldering in a state where stress is applied will cause residual stress after the soldering that tends to cause deterioration.

[Figure 4] Using tweezers on lead root to dissipate heat

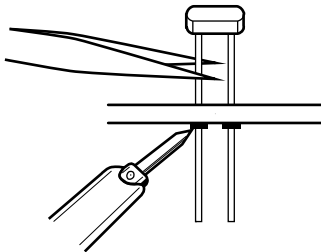

KPDC0032EA

[Figure 5] Soldering ceramic packages

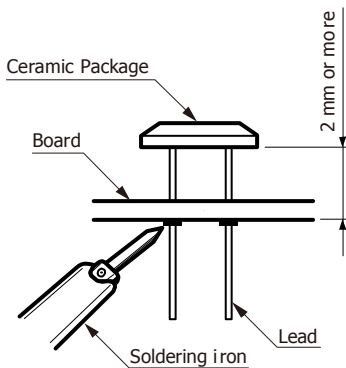

KPDC0013EC

(4) Flow (dipping) soldering

- Do flow soldering by dipping just the lead portion into a tank of solder. Do not dip the package into the solder tank. Dipping the package into the solder may cause mechanical and optical damage.
- Do flow soldering while being careful not to apply external force to the leads and package. If flow soldering is done while external force is applied, the product may easily deteriorate due to the residual stress.

4. Electrostatic sensitive devices

Electrostatic sensitive products come with an electrostatic warning label on the product packing. Handling of the product requires taking precautions on the following points to avoid damage and product deterioration due to static electricity.

[Figure 6] Electrostatic warning label

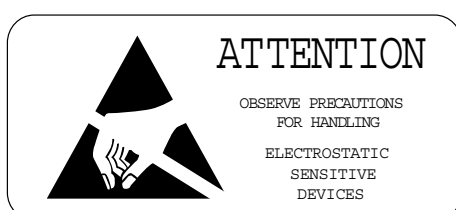

(1) Workplace and facilities, etc.

- Lay a conductive mat (750 k Ω to 1 G Ω) on the surface of the workbench and ground it.
- Use conductive flooring material or lay a conductive mat on the workplace floor and ground it.
- Ground all manufacturing equipment and inspection devices.
- Keep moisture at approximately 50%. Low humidity tends to cause static electricity and high humidity is prone to moisture absorption.

(2) Handling

- Using an ionizer or similar item to eliminate electrical charges is recommended when handling the product.
- Wear anti-static clothing and conductive shoes (100 k Ω to 100 M Ω).
- Attach a wrist strap (having protective resistance of 750 k Ω to 35 M Ω) directly to the skin, and ground the strap. If the wrist strap does not include protective resistance, there is a risk of electric shock hazard due to electric leak. Also wear conductive finger sacks or gloves.
- Tools such as tweezers used to handle the product may sometimes become electrically charged. Connect a ground line as needed.
- Use a soldering iron with an insulation resistance of 10 M Ω or higher. The soldering iron tip should be grounded.
- If the product is induction-charged and contacts with a metal, excessive current may flow due to electrostatic discharge causing damage to the product. To prevent induction charging, keep objects (insulators such as plastic and vinyl, PC display monitors and keyboards, etc. that may possibly be electrically charged) away from the product. The product may be induction-charged even by just bringing such objects close to the product. If keeping such objects near the product is unavoidable, then use an ionizer, etc. to remove electrostatic charges from the objects that are apt to be electrostatically charged.
- Friction on the product causes electrostatic charges. If such friction is unavoidable, then remove the electrostatic charges using an ionizer, etc.
- Peripheral devices must be properly grounded so that no surges are applied to the product by a leakage voltage. Do not allow a voltage exceeding the absolute maximum ratings to be applied to the product from the measurement instrument, etc. (This tends to occur during ON/OFF switching of power sources, so use caution.) If there is the possibility of a surge voltage, insert a filter (made up of a resistor and capacitor) to protect the product. During operation do not attach or detach any connector, etc. that are connected to the power supply line or output line.

(3) Carrying, storage and packing

- Place the product on a conductive foam by inserting the leads into the foam (for shorting leads) and then put it in a conductive case. The PC board to mount the product should also be put in a conductive case. Also, avoid using plastic or styrofoam as they may generate static electricity by vibration during shipping, etc. causing breakdown or deterioration of the product.
- Use a conductive carrying case and storage shelf.
- Avoid storing the product near equipment that may generate high voltage or high electromagnetic fields.

Note: It is not always necessary to provide all the anti-electrostatic measures stated above. Implement these measures according to the extent of deterioration or damage that may occur.

[Figure 7] Electrostatic countermeasure example

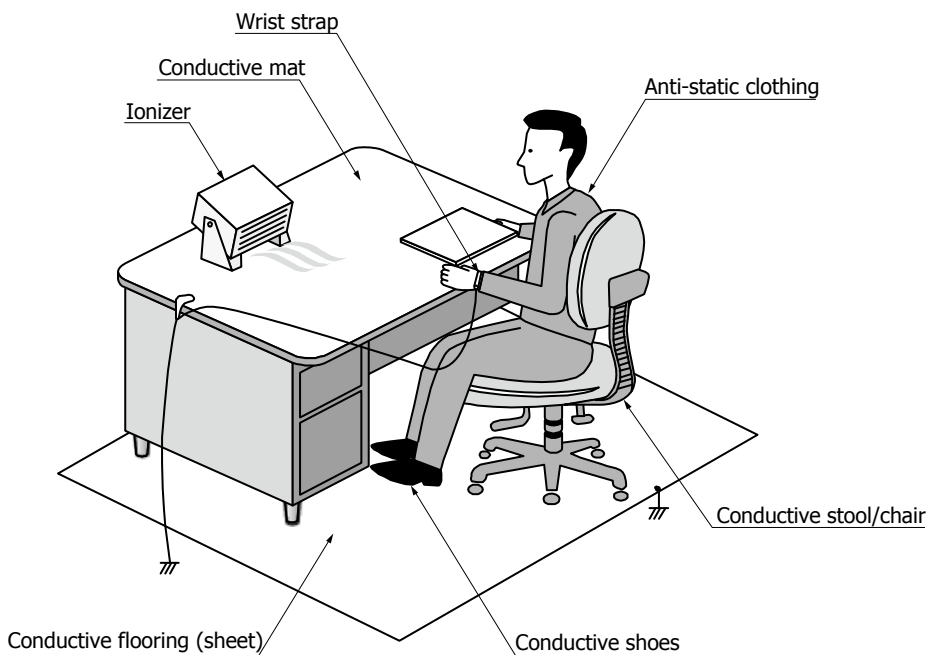

KOTH0031EB

5. Handling in cardboard boxes

The product comes shipped in cardboard boxes. Care must be taken with the following points during cardboard box handling.

- During handling, comply with warning labels displayed on the cardboard box.
- Do not set the cardboard box upside down or stand it on one end. Doing so will apply an undesired force to the product that might cause breakage.
- Take care not to apply impacts from dropping or excessive vibration to the cardboard box during handling.

[Figure 8] Warning displays on cardboard box

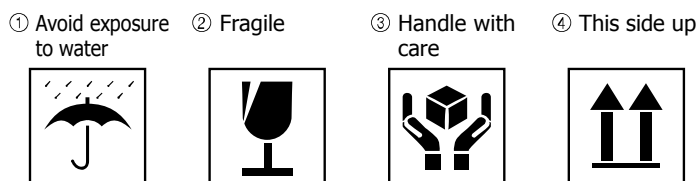

KOTH0030EB

HAMAMATSU

www.hamamatsu.com

HAMAMATSU PHOTONICS K.K., Solid State Division

1126-1 Ichino-cho, Higashi-ku, Hamamatsu City, 435-8558 Japan, Telephone: (81) 53-434-3311, Fax: (81) 53-434-5184

U.S.A.: Hamamatsu Corporation: 360 Foothill Road, P.O.Box 6910, Bridgewater, N.J. 08807-0910, U.S.A., Telephone: (1) 908-231-0960, Fax: (1) 908-231-1218

Germany: Hamamatsu Photonics Deutschland GmbH: Arzbergerstr. 10, D-82211 Herrsching am Ammersee, Germany, Telephone: (49) 8152-375-0, Fax: (49) 8152-265-8

France: Hamamatsu Photonics France S.A.R.L.: 19, Rue du Saule Trapu, Parc du Moulin de Massy, 91882 Massy Cedex, France, Telephone: 33-(1) 69 53 71 00, Fax: 33-(1) 69 53 71 10

United Kingdom: Hamamatsu Photonics UK Limited: 2 Howard Court, 10 Tewin Road, Welwyn Garden City, Hertfordshire AL7 1BW, United Kingdom, Telephone: (44) 1707-294888, Fax: (44) 1707-325777

North Europe: Hamamatsu Photonics Norden AB: Smidesvägen 12, SE-171 41 Solna, Sweden, Telephone: (46) 8-509-031-00, Fax: (46) 8-509-031-01

Italy: Hamamatsu Photonics Italia S.R.L.: Strada della Moia, 1 int. 6, 20020 Arese, (Milano), Italy, Telephone: (39) 02-935-81-733, Fax: (39) 02-935-81-741

China: Hamamatsu Photonics (China) Co., Ltd.: 1201 Tower B, Jiaming Center, No.27 Dongsanhuan Bellu, Chaoyang District, Beijing 100020, China, Telephone: (86) 10-6586-6006, Fax: (86) 10-6586-2866

KXX-A12028 A