

LAMP

5 W XENON FLASH LAMP MODULES



①: L9455/L9456 series (side-on type) ②: L11035/L11036 series (head-on type) ③: L11316/L11317 series (high output type)
④: L9455 (SMA fiber adapter type) ⑤: L9455/L9456 series (high precision type) ⑥: L9455/L9456 series (silent type)

* SMA fiber is sold separately.

OVERVIEW

Hamamatsu offers xenon flash lamp modules containing a 5 W xenon flash lamp along with its power supply and trigger socket. Up to 5 W of energy can be input, which is the maximum among lamp modules of this size. These xenon flash lamp modules also deliver high stability and long service life, making them ideal as a light source for water quality and atmospheric analyzers.

Different types of lamp modules are provided: side-on type, head-on type, and twice higher light output type than the other lamp modules currently in use.

Also offered are the SMA fiber adapter type, silent type, and high precision type.

APPLICATIONS

- Blood analyzers
- Laboratory testing
- Air pollution analysis
- Water quality and pollution analysis
- Microplate readers
- Fluorescence spectrophotometers
- Semiconductor inspection
- Light sources for image processing

FEATURES

- High stability... 1.5 % CV or less
- Long life... 1×10^9 flashes or more
- Compact size
- Repetitive emission frequency ... 530 Hz Max.
- Broad emission spectrum ... Covers from UV to near IR
- Compatible with SMA fibers ... No lens design required
- Silent type ... Audible noise reduced to 1/10 or less
- High precision type ... ± 0.05 mm precision
- Internal EMC noise filter ... Electromagnetic noise reduced to CISPR 11 Class B

HIGHLY STABLE TYPE FOR ANALYTICAL INSTRUMENTS

TYPE NUMBER GUIDE

L O O O O - A B

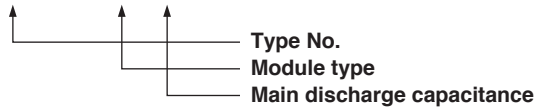

●Type No.

Type No.	Arc size	Type	Maximum input
L9455	1.5 mm	Side-on	50 mJ
L9456	3.0 mm		
L11035 *	1.5 mm	Head-on	50 mJ
L11036 *	3.0 mm		

* Make to order

A: Module type

Suffix	Module type
0	Standard
1	SMA fiber adapter
2 *	Silent
4 *	High precision

* Make to order

* The L9456 and L11036 are not available as a module with an SMA fiber adapter.

B: Main discharge capacitance

Suffix	Capacitance
1	0.22 μ F
2	0.11 μ F
3	0.047 μ F
4	0.28 μ F

Window material change, built-in EMC noise filter and lamp electrode angle change are available as options. please feel free to consult us.

SPECIFICATIONS

Parameter	L9455 series	L9456 series	Unit
	L11035 series	L11036 series	
Arc size	1.5	3.0	mm
Window material	UV glass		—
Emission wavelength range	185 to 2000		nm
Main discharge voltage variable range *1	400 to 600		V
Main discharge capacitor *2	0.22 / 0.11 / 0.047 / 0.28		μ F
Maximum input energy (per flash) *3	See operating conditions.		—
Maximum average input (continuous) *4	5		W
Light output stability (Max.) *5	2.0	1.5	% CV
Guaranteed life *6	1×10^9		flashes
Input voltage range	11 to 28		V
Input current	1		A
Inrush current	4		A
Trigger input	Rectangular wave 5 V to 10 V; pulse width must be 10 μ s or more. *7		—
Trigger input impedance	330		Ω
Cooling method	Not required *8		—
Weight (standard type: L9455-01)	Approx. 155		g
Operating temperature range	0 to +40		$^{\circ}$ C
Storage temperature range	-40 to +90		$^{\circ}$ C
Storage humidity range	Below 95 (no condensation)		% RH
EMC standards	Without EMC noise filter	IEC61326-1: 2005 Group1, ClassA	
	With EMC noise filter	IEC61326-1: 2005 Group1, ClassB	
Safety standards	IEC62471: 2006 Risk Group3		—

NOTE:

- *1 Internal: Adjustable with variable trimmer.
External: Variable with control voltage from 3.2 V to 4.8 V.
- *2 Installed at time of shipment (refer to the above lineups).
- *3 Maximum lamp input energy (per flash)
 $E = 1/2 CV^2$
E: Maximum lamp input energy (J)
V: Main discharge voltage (V)
C: Main discharge capacitance (F)
- *4 Maximum average lamp input (continuous)
 $W = E \times f$
f: Lamp emission repetition frequency (Hz)
- *5 Light output stability is given by:
Light output stability (% CV) = light output standard deviation / average light output \times 100
- *6 At 5 W operation
- *7 Only for external control; synchronized with rising edge.
- *8 Cooling is required when the package temperature exceeds 50 $^{\circ}$ C during operation.

VIBRATION AND SHOCK RESISTANCE

Resistance to vibration: 5 Hz to 200 Hz, 15 m/s²

Resistance to shock: 500 m/s²

OPERATING CONDITIONS

Type No.	Main discharge capacitor (μF)	Main discharge voltage (V)	Maximum input energy [per flash] (mJ)	Maximum repetition rate (Hz)	Maximum input (W)
L9455/L9456-○1 L11035/L11036-○1	0.22	400	17.6	284	5.0
		500	27.5	182	5.0
		600	39.6	126	5.0
L9455/L9456-○2 L11035/L11036-○2	0.11	400	8.8	530	4.7
		500	13.8	362	5.0
		600	19.8	252	5.0
L9455/L9456-○3 L11035/L11036-○3	0.047	400	3.8	530	2.0
		500	5.9	530	3.1
		600	8.5	530	4.5
L9455/L9456-○4 L11035/L11036-○4	0.28	400	22.4	223	5.0
		500	35.0	142	5.0
		600	50.4	100	5.0

CHARACTERISTICS

●LIGHT OUTPUT STABILITY * (Typical initial value)

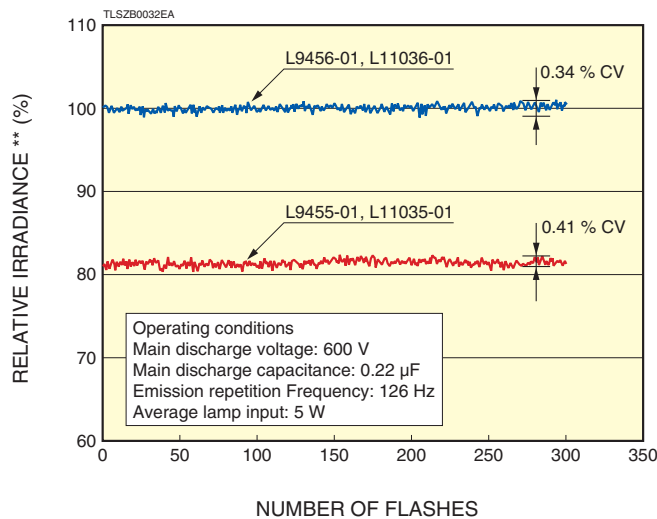

* Light output stability (% CV) = light output standard deviation / average light output × 100
 ** Output value with average light output of L9456-01 set to 100%.

Measurement block diagram

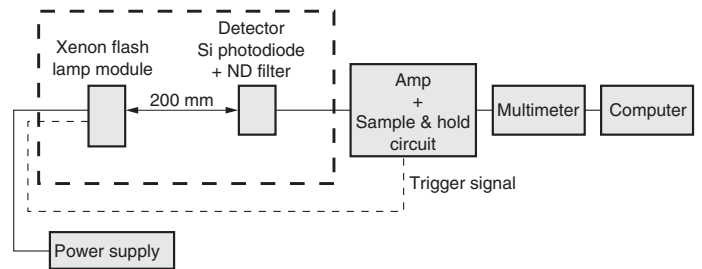

TLSZC0009EB

●LIFE CHARACTERISTICS

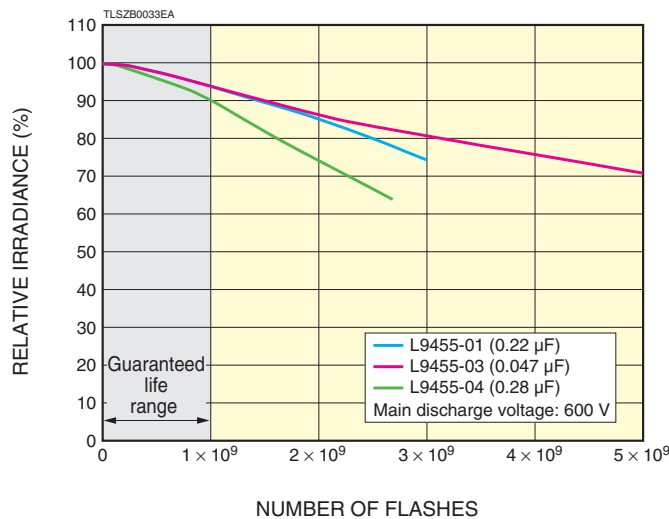

●SPECTRAL DISTRIBUTION (L9455 -01 series)

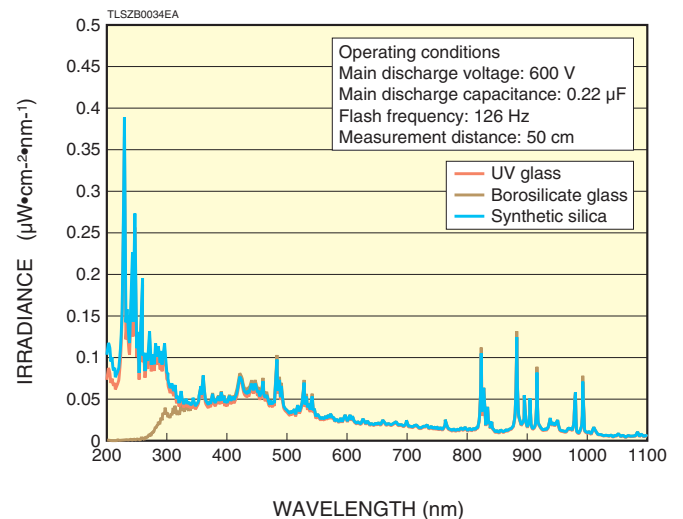

CHARACTERISTICS

●EMISSION PULSE WAVEFORM

Waveform difference by arc length

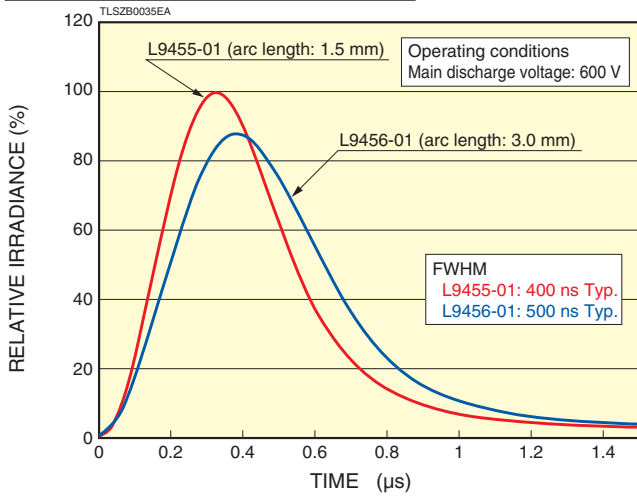

●DIRECTIVITY (LIGHT DISTRIBUTION) (L9455/L9456 series)

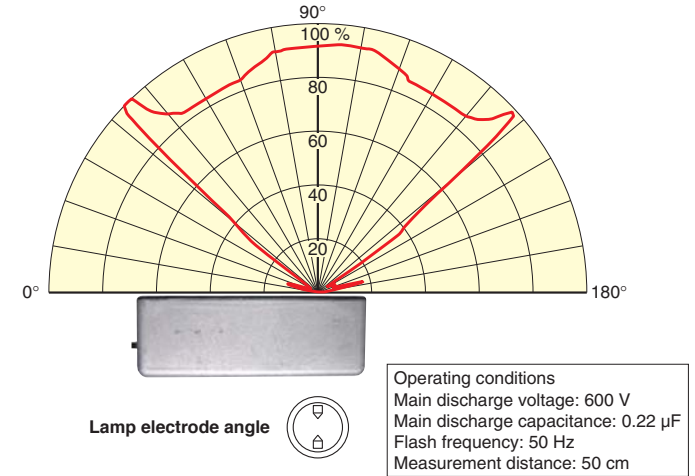

Waveform difference by main discharge capacitance

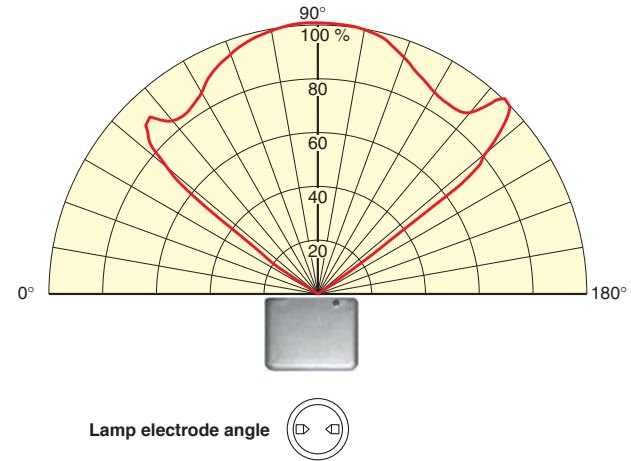
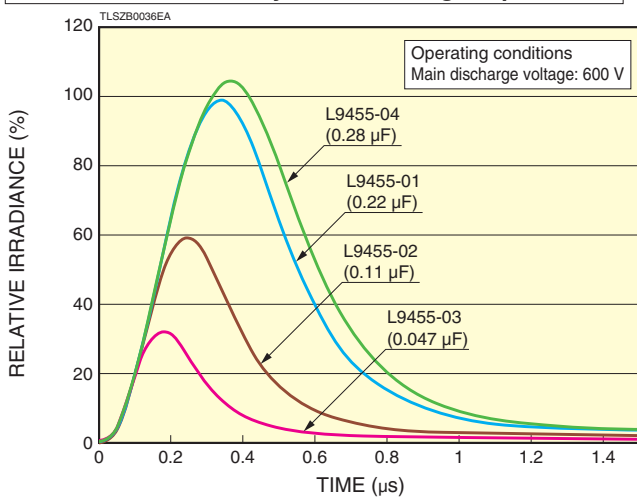

TLSZB0037EA

DIMENSIONAL OUTLINES (unit: mm)

STANDARD TYPE

●L9455-0○, L9456-0○

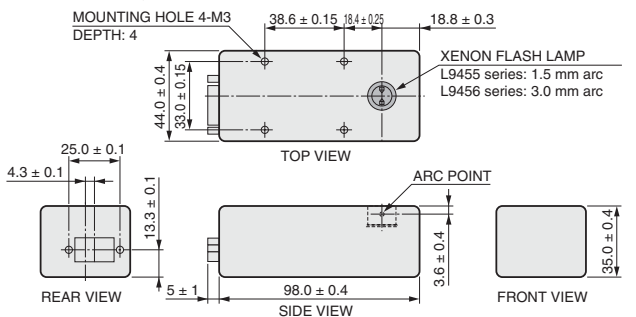

●L11035-0○, L11036-0○

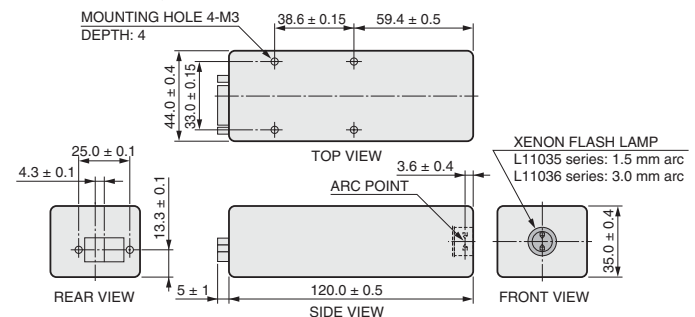

INTERNAL/EXTERNAL SELECTOR SWITCH FOR MAIN DISCHARGE VOLTAGE

INTERNAL/EXTERNAL SELECTOR SWITCH FOR MAIN DISCHARGE VOLTAGE

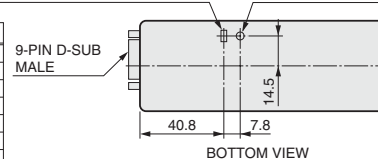
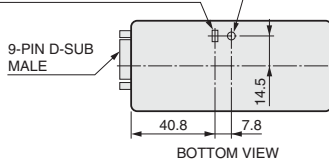

9-pin D-sub connection

Pin No.	Signal
1	+ input voltage (11 V to 28 V) ^(A)
2	+ input voltage (11 V to 28 V) ^(A)
3	+ main discharge voltage control (3.2 V to 4.8 V)
4	Trigger RTN ^(B)
5	+ trigger input ^(B)
6	Input voltage RTN
7	Input voltage RTN
8	Main discharge voltage control RTN
9	No connection

^(A) Input current: 1 A, Inrush current: 4 A

^(B) Trigger input: 5 V to 10 V rectangular waveform (pulse width: 10 μs or more)

Package must be grounded, for example, by using an M3 screw for mounting holes.

TLSXA0099EF

TLSZA0009EF

DIMENSIONAL OUTLINES (Unit: mm)

SMA FIBER ADAPTER TYPE

●L9455-1○

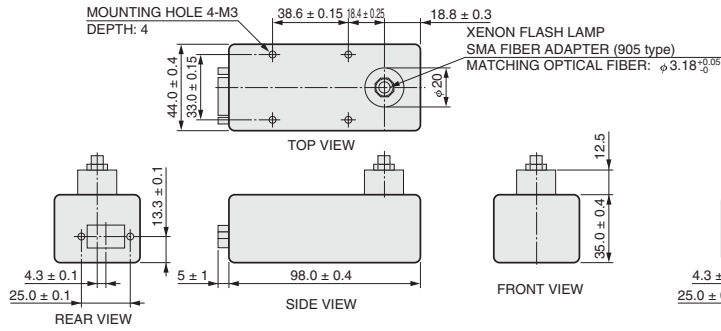

●L11035-1○

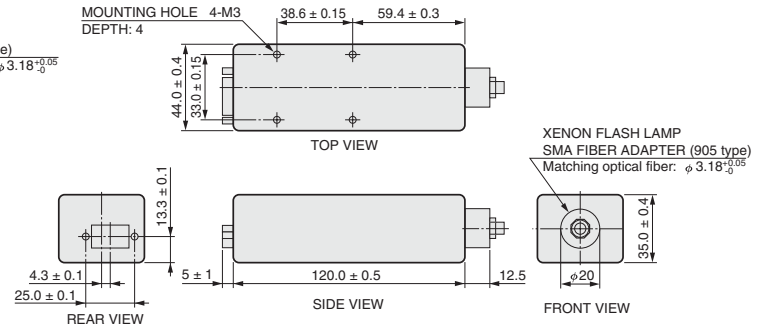

INTERNAL/EXTERNAL SELECTOR SWITCH FOR MAIN DISCHARGE VOLTAGE

TRIMMER FOR MAIN DISCHARGE VOLTAGE

INTERNAL/EXTERNAL SELECTOR SWITCH FOR MAIN DISCHARGE VOLTAGE

TRIMMER FOR MAIN DISCHARGE VOLTAGE

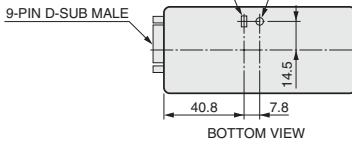

9-pin D-sub connection

Pin No.	Signal
1	+ input voltage (11 V to 28 V) [Ⓐ]
2	+ input voltage (11 V to 28 V) [Ⓐ]
3	+ main discharge voltage control (3.2 V to 4.8 V)
4	Trigger RTN [Ⓑ]
5	+ trigger input [Ⓑ]
6	Input voltage RTN
7	Input voltage RTN
8	Main discharge voltage control RTN
9	No connection

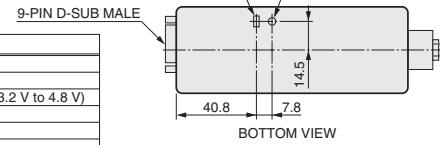

[Ⓐ] Input current: 1 A, Inrush current: 4 A
[Ⓑ] Trigger input: 5 V to 10 V rectangular waveform (pulse width: 10 μ s or more)
 Package must be grounded, for example, by using an M3 screw for mounting holes.

TLSXA0107EE

TLSZA0010EC

SILENT TYPE Emitting points are different.

●L9455-2○, L9456-2○

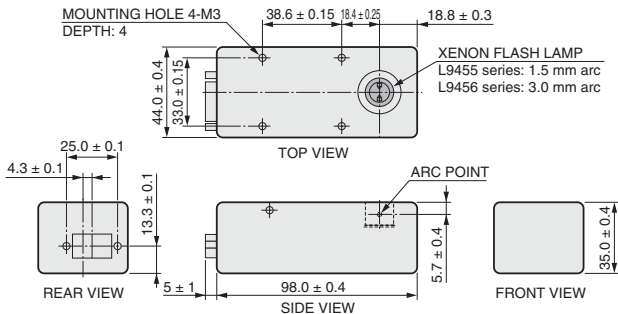

●L11035-2○, L11036-2○

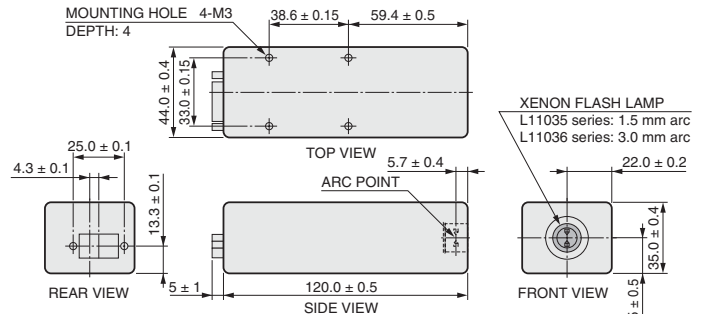

INTERNAL/EXTERNAL SELECTOR SWITCH FOR MAIN DISCHARGE VOLTAGE

TRIMMER FOR MAIN DISCHARGE VOLTAGE

INTERNAL/EXTERNAL SELECTOR SWITCH FOR MAIN DISCHARGE VOLTAGE

TRIMMER FOR MAIN DISCHARGE VOLTAGE

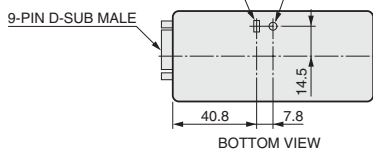

9-pin D-sub connection

Pin No.	Signal
1	+ input voltage (11 V to 28 V) [Ⓐ]
2	+ input voltage (11 V to 28 V) [Ⓐ]
3	+ main discharge voltage control (3.2 V to 4.8 V)
4	Trigger RTN [Ⓑ]
5	+ trigger input [Ⓑ]
6	Input voltage RTN
7	Input voltage RTN
8	Main discharge voltage control RTN
9	No connection

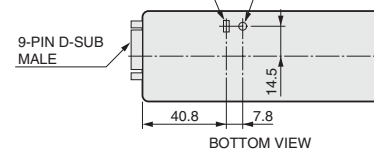

[Ⓐ] Input current: 1 A, Inrush current: 4 A
[Ⓑ] Trigger input: 5 V to 10 V rectangular waveform (pulse width: 10 μ s or more)
 Package must be grounded, for example, by using an M3 screw for mounting holes.

TLSZA0014EB

TLSZA0015EB

HIGH PRECISION TYPE Positioning pins are provided in the lamp position.

●L9455-4○, L9456-4○

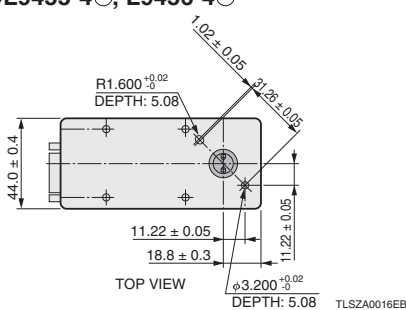

●L11035-4○, L11036-4○

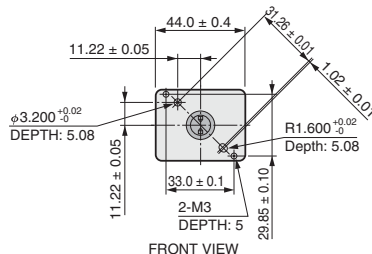

TLSZA0016EB

TLSZA0017EB

HIGH OUTPUT TYPE

TYPE NUMBER GUIDE

L O O O O - A B

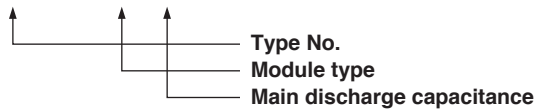

●Type No.

Type No.	Arc size	Type	Maximum input
L11316	1.5 mm	Side-on	100 mJ
L11317	3.0 mm		

A: Module type

Suffix	Module type
0	Standard
1	SMA fiber adapter
2 *	Silent
4 *	High precision

* Make to order

*The L11317 is not available as a module with an SMA fiber adapter.

B: Main discharge capacitance

Suffix	Capacitance
1	0.2 μ F
2	0.1 μ F

Window material selection, built-in EMC noise filter and lamp electrode angle change are available as options. please feel free to consult us.

SPECIFICATIONS

Parameter	L11316 series	L11317 series	Unit
Arc size	1.5	3.0	mm
Window material	UV glass		—
Emission wavelength range	185 to 2000		nm
Main discharge voltage	Internal	650 to 1000	V
Main discharge voltage variable range *1	External	500 to 1000	
Main discharge capacitance *2	0.2 /0.1		μ F
Maximum input energy (per flash) *3	See operating conditions.		J
Maximum average input (continuous) *4	5		W
Light output stability (Max.) *5	3.0	2.5	% CV
Guaranteed life *6	5×10^8		flashes
Input voltage range	21.6 to 26.4		V
Input current	0.75		A
Inrush current	3		A
Trigger input	Rectangular waveform 5 V to 10 V; pulse width must be 10 μ s or more *7		—
Trigger input impedance	330		Ω
Cooling method	Not required *8		—
Weight (standard type: L11316-01)	Approx. 328		g
Operating temperature range	0 to +40		$^{\circ}$ C
Storage temperature range	-40 to +90		$^{\circ}$ C
Storage humidity range	Below 95 (no condensation)		% RH
EMC standards	Without EMC noise filter	IEC61326-1: 2005 Group1, ClassA	—
	With EMC noise filter	IEC61326-1: 2005 Group1, ClassB	
Safety standards	IEC61010-1: 2010		—
	IEC62471: 2006 Risk Group3		

NOTE:

- *1 Internal: Adjustable with variable trimmer.
External: Variable with control voltage from 2.44 V to 4.88 V.
- *2 Installed at time of shipment (refer to the above lineups).
- *3 Maximum lamp input energy (per flash)
 $E=1/2 CV^2$
E: Maximum lamp input energy (J)
V: Main discharge voltage (V)
C: Main discharge capacitance (F)
- *4 Maximum average lamp input (continuous)
 $W=E \times f$
f: Lamp emission repetition frequency (Hz)
- *5 Light output stability is given by:
Light output stability (% CV) =
light output standard deviation /
average light output $\times 100$
- *6 At 5 W operation
- *7 Only for external control;
synchronized with rising edge.
- *8 Cooling is required when the
package temperature exceeds
50 $^{\circ}$ C during operation.

VIBRATION AND SHOCK RESISTANCE

Resistance to vibration: 5 Hz to 200 Hz, 15 m/s²

Resistance to shock: 500 m/s²

OPERATING CONDITIONS

Type No.	Main discharge capacitor (μF)	Main discharge voltage (V)	Maximum input energy [per flash] (mJ)	Maximum repetition rate (Hz)	Maximum input (W)
L11316-01 L11317-01	0.2	500	25.0	200	5.0
		700	49.0	102	5.0
		1000	100.0	50	5.0
L11316-02 L11317-02	0.1	500	12.5	400	5.0
		700	24.5	204	5.0
		1000	50.0	100	5.0

CHARACTERISTICS

●EMISSION PULSE WAVEFORM

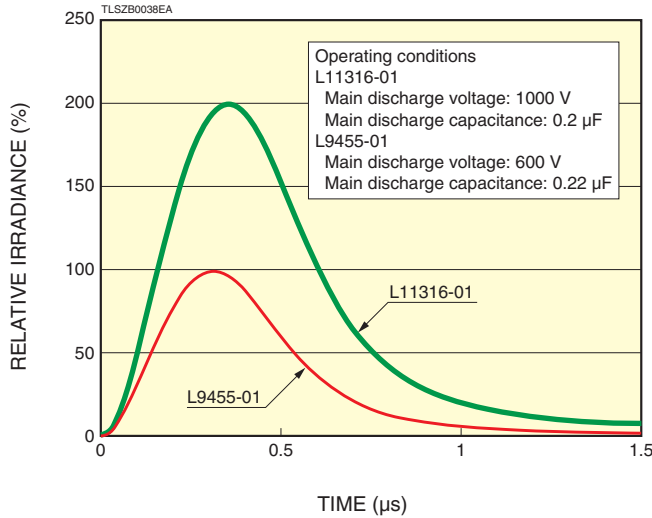

●LIFE CHARACTERISTICS (L11316-01)

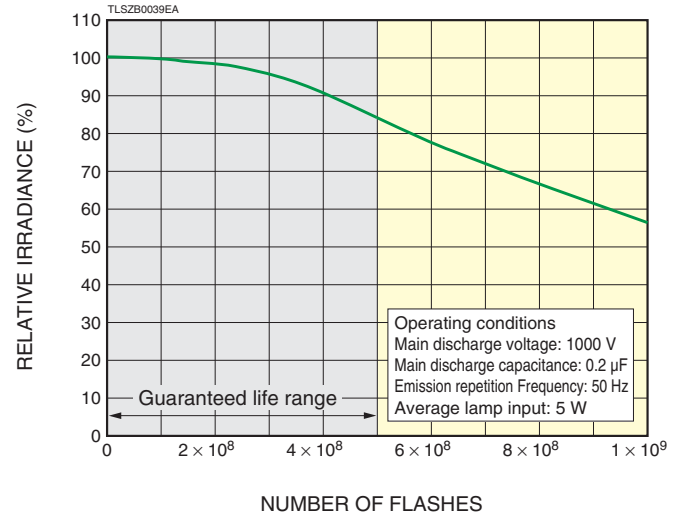

DIMENSIONAL OUTLINES (unit: mm)

STANDARD TYPE

●L11316-00, L11317-00

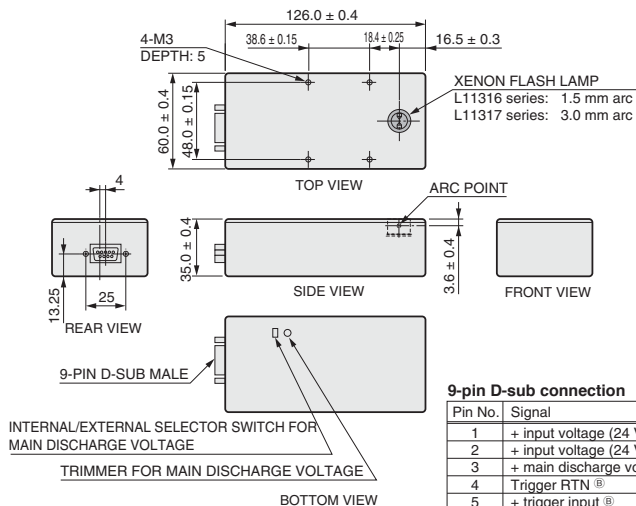

9-pin D-sub connection

Pin No.	Signal
1	+ input voltage (24 V ± 2.4 V) [Ⓐ]
2	+ input voltage (24 V ± 2.4 V) [Ⓐ]
3	+ main discharge voltage control (2.44 V to 4.88 V)
4	Trigger RTN [Ⓑ]
5	+ trigger input [Ⓑ]
6	Input voltage RTN
7	Input voltage RTN
8	Main discharge voltage control RTN
9	No connection

[Ⓐ] Input current: 0.75 A, Inrush current: 3 A

[Ⓑ] Trigger input: 5 V to 10 V rectangular waveform (pulse width: 10 ms or more)

Package must be grounded, for example, by using an M3 screw for mounting holes.

TLSZA0018EB

SMA FIBER ADAPTER TYPE

●L11316-10

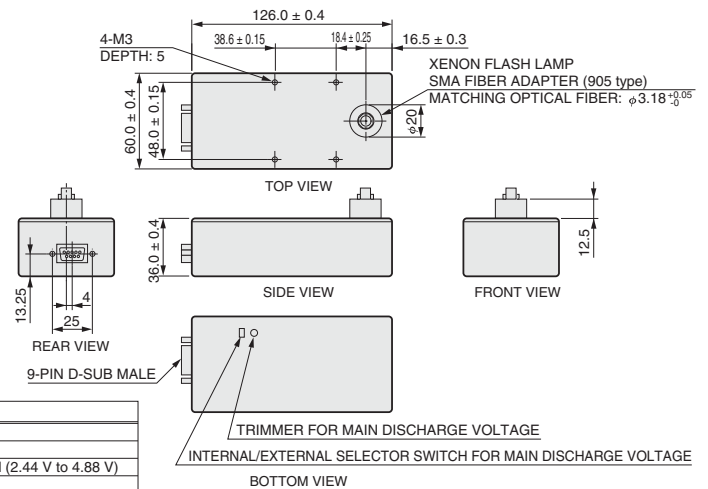

TLSZA0019EB

DIMENSIONAL OUTLINES (Unit: mm)

SILENT TYPE Emitting points are different.

●L11316-2○, L11317-2○

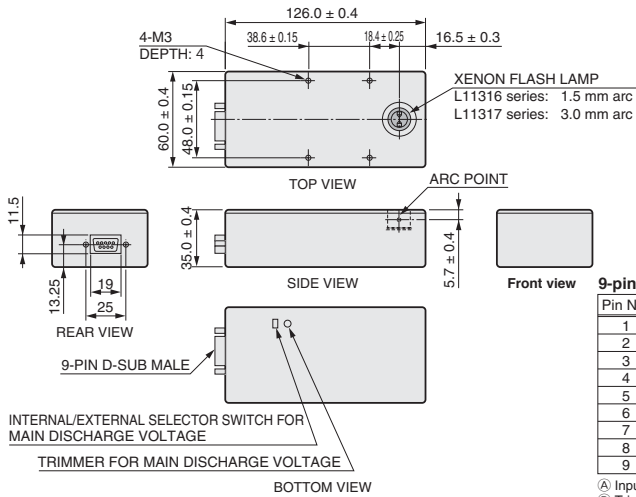

TLSZA0020EB

HIGH PRECISION TYPE Positioning guides are provided in the lamp position.

●L11316-4○, L11317-4○

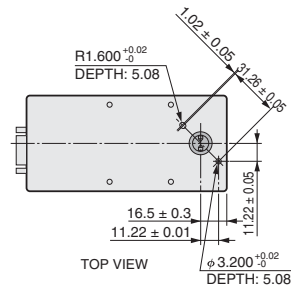

TLSZA0021EB

9-pin D-sub connection

Pin No.	Signal
1	+ input voltage (24 V ± 2.4 V) ^(A)
2	+ input voltage (24 V ± 2.4 V) ^(A)
3	+ main discharge voltage control (2.44 V to 4.88 V)
4	Trigger RTN ^(B)
5	+ trigger input ^(B)
6	Input voltage RTN
7	Input voltage RTN
8	Main-discharge-voltage control RTN
9	No connection

^(A) Input current: 0.75 A, Inrush current: 3 A

^(B) Trigger input: 5 V to 10 V rectangular waveform (pulse width: 10 ms or more)

Package must be grounded, for example, by using an M3 screw for mounting holes.

RELATED PRODUCTS

■UV-RESISTANT LIGHT GUIDE (Sold separately)

These light guides have SMA905 optical fiber connectors at both ends and are designed to minimize loss of UV transmittance. On synthetic silica lamp modules, use the A11691-06AS as a light guide.

●DIMENSIONAL OUTLINE (Unit: mm)

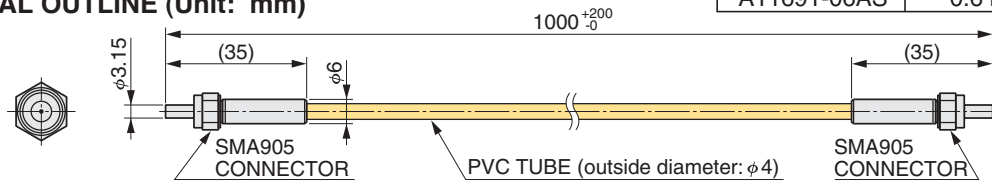

TLSZA0021EB

Type No.	Core diameter	Length
A7969-06AS	0.6 mm	1.0 m
A7969-08AS	0.8 mm	
A11691-06AS	0.6 mm	

■SHIELD CABLE WITH D-SUB INPUT CONNECTOR A11690 (Sold separately)

Besides grounding the module case, properly shielding the cable is important to reduce noise in xenon flash lamp modules. The A11690 is a shielded cable with a D-sub input connector that is extremely effective in reducing noise. Standard cable length is 300 mm but other lengths are available on request. Please consult our sales office if needed.

●DIMENSIONAL OUTLINE (Unit: mm)

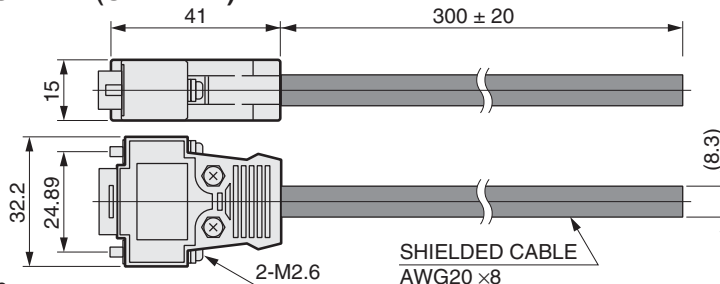

1. Brown : + input voltage
2. Red : + input voltage
3. Blue : + main discharge voltage control
4. Yellow : Trigger RTN.
5. Green : + trigger input
6. White : Input voltage RTN
7. Black : Input voltage RTN
8. Gray : Main-discharge-voltage control RTN

TLSZA0023EB

* Patent pending: 2 patents

Subject to local technical requirements and regulations, availability of products included in this promotional material may vary. Please consult with our sales office. Information furnished by HAMAMATSU is believed to be reliable. However, no responsibility is assumed for possible inaccuracies or omissions. Specifications are subject to change without notice. No patent rights are granted to any of the circuits described herein. ©2015 Hamamatsu Photonics K.K.

HAMAMATSU PHOTONICS K.K. www.hamamatsu.com

HAMAMATSU PHOTONICS K.K., Electron Tube Division

314-5, Shimokanzo, Iwata City, Shizuoka Pref., 438-0193, Japan, Telephone: (81)539/62-5248, Fax: (81)539/62-2205

U.S.A.: Hamamatsu Corporation, 360 Foothill Road, Bridgewater, N.J. 08807-0910, U.S.A., Telephone: (1)908-231-0960, Fax: (1)908-231-1218 E-mail: usa@hamamatsu.com

Germany: Hamamatsu Photonics Deutschland GmbH, Arzbergerstr. 10, D-82211 Herrsching am Ammersee, Germany, Telephone: (49)8152-375-0, Fax: (49)8152-2658 E-mail: info@hamamatsu.de

France: Hamamatsu Photonics France S.A.R.L.: 19, Rue du Saule Trapu, Parc du Moulin de Massy, 91882 Massy Cedex, France, Telephone: (33)1 69 53 71 00, Fax: (33)1 69 53 71 10 E-mail: infos@hamamatsu.fr

United Kingdom: Hamamatsu Photonics UK Limited: 2 Howard Court, 10 Tewin Road, Welwyn Garden City, Hertfordshire AL7 1BW, United Kingdom, Telephone: (44)1707-294888, Fax: (44)1707-325777 E-mail: info@hamamatsu.co.uk

North Europe: Hamamatsu Photonics Norden AB: Torshamnsgatan 35 SE-164 40 Kista, Sweden, Telephone: (46)8-509-031-00, Fax: (46)8-509-031-01 E-mail: info@hamamatsu.se

Italy: Hamamatsu Photonics Italia S.r.l.: Strada della Moia, 1 int. 6, 20020 Arese (Milano), Italy, Telephone: (39)02-93581733, Fax: (39)02-93581741 E-mail: info@hamamatsu.it

China: Hamamatsu Photonics (China) Co., Ltd.: B1201 Jiaming Center, No.27 Dongsanhuan Beilu, Chaoyang District, Beijing 100020, China, Telephone: (86)10-6586-6006, Fax: (86)10-6586-2866 E-mail: hpc@hamamatsu.com.cn

TLSZ1006E04

MAY 2015 IP