

Technical information

Back-thinned TDI-CCD

1 What is a back-thinned TDI-CCD?

Back-thinned TDI (time delay integration)-CCDs allow acquiring high S/N images even under low-light conditions during high-speed imaging and the like. TDI operation yields dramatically enhanced sensitivity by integrating the exposure of a moving object. The back-thinned structure ensures high quantum efficiency over a wide spectral range from the ultraviolet to the near infrared region (200 to 1100 nm).

[Figure 1-1] TDI operation illustration

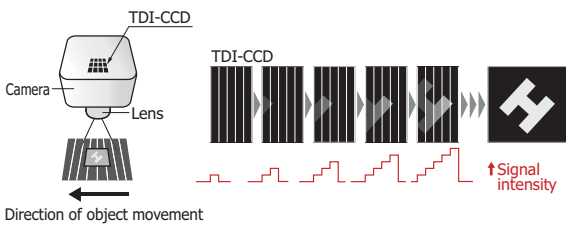

□ TDI operation

In CCD operation, a signal charge is transferred to the output section while being held in potential wells so as not to mix with other individual charges. TDI operation makes good use of this CCD charge transfer principle, and it is an effective technique for imaging a moving object or a still object while scanning it with a CCD sensor that is itself being moved.

Normally, an image focused on the CCD sensor is output as a signal corresponding to the focused position. This means that the image focused within the integration time must stay in the same position on the CCD sensor. If, for some reason, the focused position is shifted, then the image S/N will deteriorate. When an object is moving, the focused position will shift, causing the image to blur or, in some cases, no image to appear.

The TDI operation, in contrast, is a unique operation that captures images of a moving object. In FFT-CCD, signal charges in each column are vertically transferred during charge readout. TDI operation synchronizes this vertical transfer timing with the movement of the object, so signal charges are integrated by a number of times equal to the number of vertical stages of the CCD pixels.

In TDI operation, the signal charges must be transferred

in the same direction at the same speed as those of the object to be imaged. These speeds are expressed by equation (1).

$$v = f \times d \dots\dots\dots (1)$$

- v: object speed, charge transfer speed
- f: vertical CCD transfer frequency
- d: pixel size (transfer direction)

In Figure 1-2, when the charge accumulated in the first stage is transferred to the second stage, another charge produced by photoelectric conversion is simultaneously accumulated in the second stage. Repeating this operation continuously until reaching the last stage M (number of vertical stages) results in a charge accumulation M times greater than the initial charge. This shows that the TDI operation enhances sensitivity up to M times higher than ordinary linear image sensors. (If the number of vertical stages is 128, the sensitivity will be 128 times higher than ordinary linear image sensors.) Since the accumulated signal charges are output for each column from the CCD horizontal shift register, a two-dimensional continuous image can be obtained. TDI operation also improves sensitivity variations compared to two-dimensional operation mode.

[Figure 1-2] Schematic of integrated exposure in TDI operation

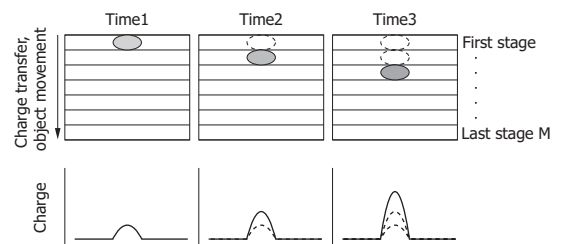

KMPDC0139EA

[Figure 1-3] Imaging examples in TDI operation

(a) Imaging of fast moving object

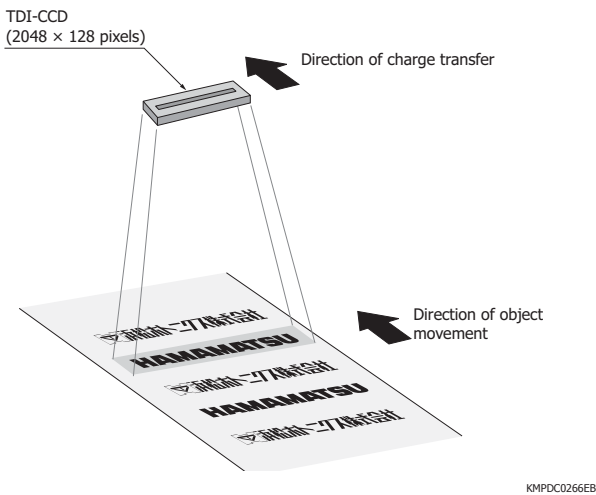

(b) Imaging of fast rotating object

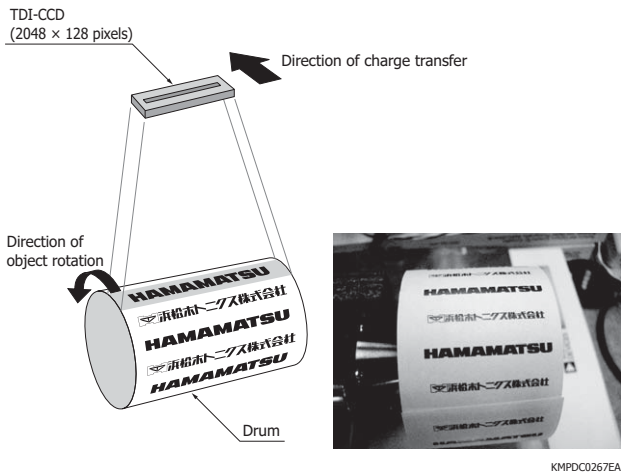

In Figure 1-3 (b), when the CCD is put in two-dimensional operation and the drum is imaged while in idle, a clear image with no blurring is obtained as shown in Figure 1-4 (a). However, when the drum is rotating, the image is blurred as shown in Figure 1-4 (b). Shortening the shutter time captures an unblurred image, but the image becomes dark as shown in Figure 1-4 (c). Using a TDI-CCD acquires clear, continuous images with no blurring as shown in Figure 1-5 since charge transfer is performed in the same direction at the same speed as those of the rotating drum.

[Figure 1-4] Imaging in two-dimensional operation

(a) When drum is in idle



(b) When drum is rotating



(c) When drum is rotating (with shutter time shortened)



[Figure 1-5] Imaging in TDI operation (continuous image during drum rotation)



2 Features

High sensitivity (UV to near IR)

Hamamatsu TDI-CCDs employ back-illuminated structure and ensure high sensitivity in the UV to near infrared region (200 to 1100 nm).

[Figure 2-1] Spectral response (without window)

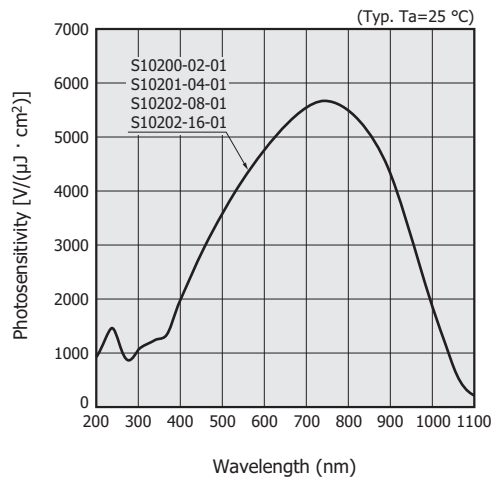

KMPD0268EB

[Figure 2-2] Quantum efficiency vs. wavelength (without window)

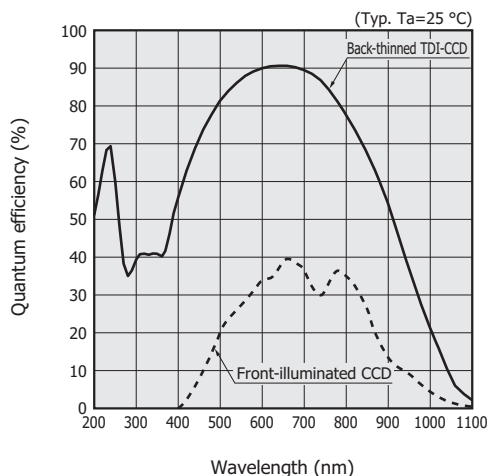

KMPDB0269EC

High-speed line rate using multiple ports

To achieve continuous imaging of high-speed moving samples, multiple amplifiers are arranged in the TDI-CCD, and images are read out in parallel. This results in high-speed line rate. The pixel rate is 30 MHz/port, and the line rate is 50 kHz on the S10200-02-01, S10201-04-01, and S10202-08-01 and 100 kHz on the S10202-16-01.

[Figure 2-3] Sensor structure [typical example: S10201-04-01, 2048 (H) × 128 (V) pixels, 4 ports per side × 2 (bidirectional transfer)]

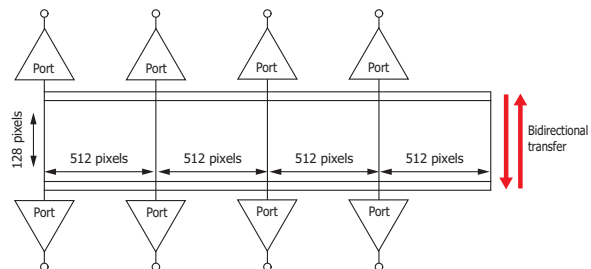

Bidirectional vertical transfer is possible.

KMPDC0268EA

When an object is scanned multiple times, the bidirectional transfer function of the TDI-CCD eliminates the need to return the camera as shown in Figure 2-4 (a), and thus the inspection throughput can be improved.

[Figure 2-4] Camera scan direction

(a) Unidirectional transfer

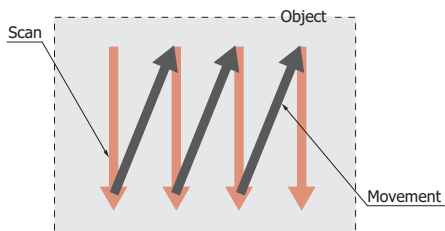

(b) Bidirectional transfer

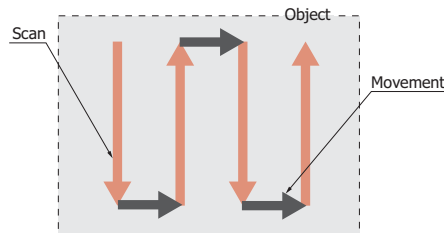

(c) Camera with bidirectional transfer TDI-CCD

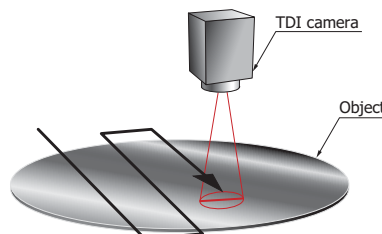

KMPDC0503EA

Anti-blooming

Blooming (overflow) is a phenomenon that occurs when high-intensity light enters the photosensitive area and the resulting signal charge exceeds a specific level. This excess charge then overflows into adjacent pixels and transfer region. A technique to prevent this is called anti-blooming which provides a drain to carry away the excess charge [Figure 2-5].

Anti-blooming structures for CCDs are roughly divided into a lateral type and a vertical type, and our CCDs use the lateral type. The lateral type structure has an overflow drain formed along the pixels or charge transfer channels. This structure has the drawback that the fill factor is reduced when used for front-illuminated CCDs. However, this problem can be avoided when used for back-thinned CCDs [Figure 2-6].

When controlling the anti-blooming function by means of the overflow drain voltage (V_{OFD}) and overflow gate voltage (V_{OFG}), these applied voltages may cause charge to flow from the drain to the pixel or decrease the saturation charge. The applied voltages must be set to appropriate values [Figure 2-7, 2-8].

[Figure 2-5] Imaging examples

(a) Without anti-blooming (b) With anti-blooming

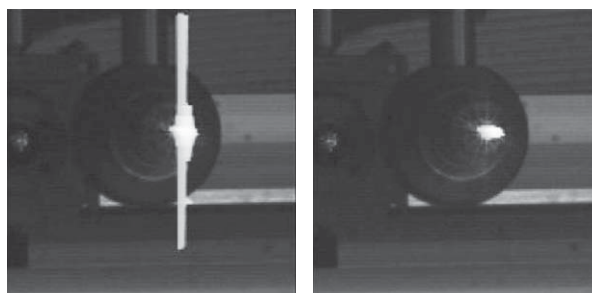

[Figure 2-6] Anti-blooming structure (lateral type) and potential (structure in which overflow drain is provided for two pixels)

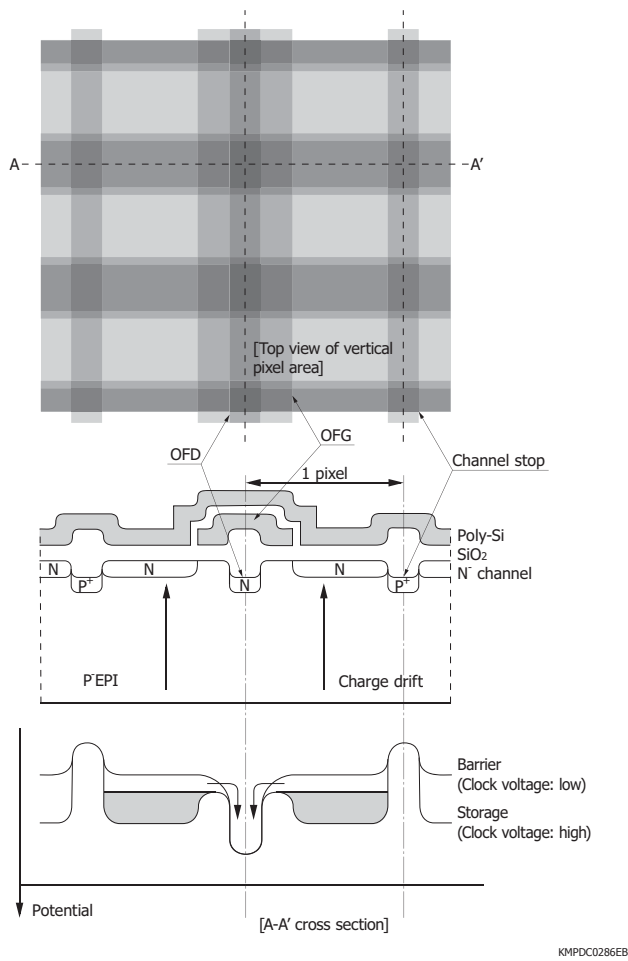

[Figure 2-7] Schematic diagram of anti-blooming (lateral type)

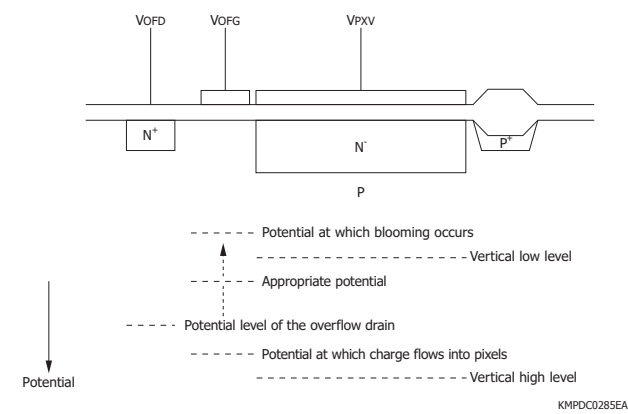

[Figure 2-8] Voltage setting and anti-blooming (schematic)

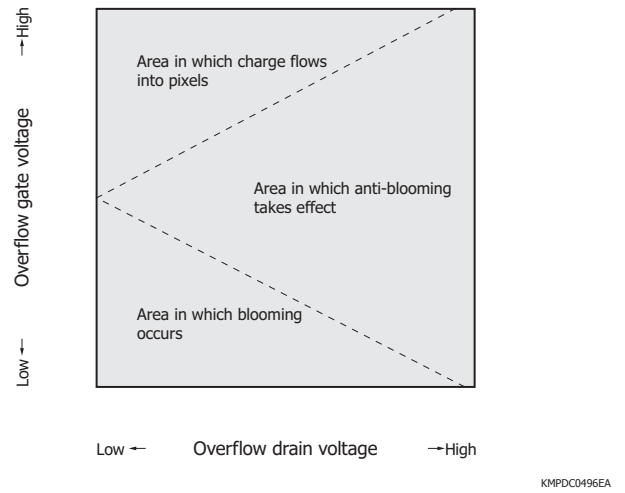

3 Comparison between previous products and new products

[Figure 3-1] Characteristic comparison between previous products and new products

Parameter	Previous product		New product		Unit
	S10200-02 S10201-04 S10202-08 S10202-16	S10200-02-01 S10201-04-01 S10202-08-01 S10202-16-01			
Output signal frequency	Typ.	30	30	MHz	
	Max.	35	40		
CCD node efficiency		3.5	9.5	$\mu\text{V}/e^-$	
Readout noise (30 MHz)		100	35	$e^- \text{ rms}$	
Dynamic range		1000	2857	-	
Operating voltage		See datasheet.	See datasheet.	-	
Output impedance		300	150	Ω	

[Figure 3-1] Output waveforms ($f_c=30 \text{ MHz}$)

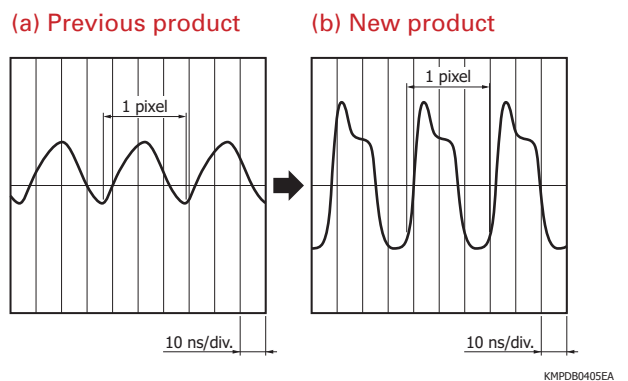

Thanks to the increased CCD node efficiency and optimized amplifier design, the new products produce output waveforms that are closer to the ideal waveform, with greater output amplitude and improved bandwidth than the previous product [Figure 3-1].

4 How to use

Reducing spurious signals

When the back-thinned CCD is viewed from the light input side, the horizontal shift register is covered by the thick area of the silicon (insensitive area) [Figure 4-1], but long-wavelength light may pass through the insensitive area. If this light is received by the horizontal shift register, it can cause spurious signals.

Spurious signals are mixed into the actual signal. If the horizontal transfer time period is longer than the total of the integration times of TDI operation, the effect of spurious signals increases.

If the effect of spurious signals is large, measures need to be taken such as adjusting the light irradiation position or shielding the horizontal shift register.

Reducing effects of dark output

Dark output is an output current that flows when no light is input. For CCDs for measurement applications, the dark output is typically expressed as the number of electrons generated per pixel per second (unit: electron/pixel/s). In TDI operation, since the dark current that is generated by the pixels of each column is integrated over the number of vertical stages, the dark current is expressed as the number of electrons generated per column (unit: electron/pixel), and its magnitude varies depending on the line rate, the number of stages, and the like. As such, at high-speed line rates, the dark current is extremely small.

Dark output nearly doubles for every 5 to 7 °C increase in temperature [Figure 4-2]. When the element temperature

increases, the effects of dark shot noise may increase, in which case an appropriate heat dissipation measures need to be taken [Figure 4-3].

If the dark offset of each column needs to be corrected, use the output from the effective pixels that is generated when there is no incident light (dark state). Note that the blank pixel output does not include signals generated by vertical pixels.

[Figure 4-2] Dark output vs. element temperature (typical example)

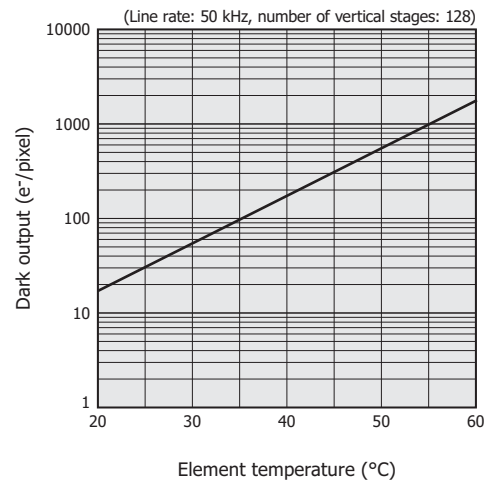

KMPDB0407EA

[Figure 4-1] Device structure (typical example: S10202-08-01, schematic of CCD chip as viewed from top of dimensional outline)

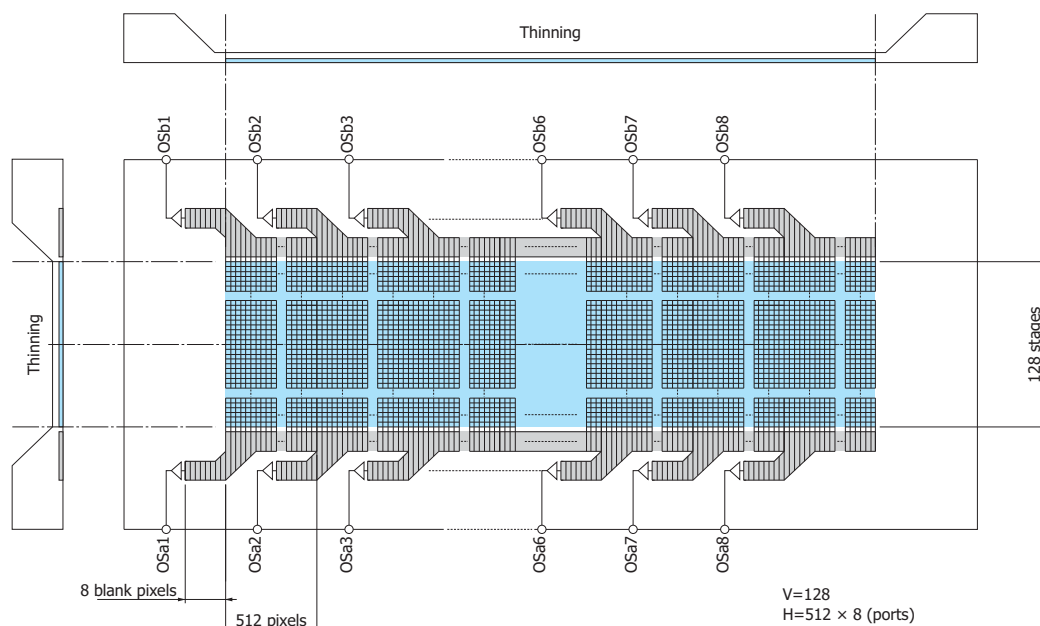

KMPDC0252EC

[Figure 4-3] Noise vs. element temperature (typical example)

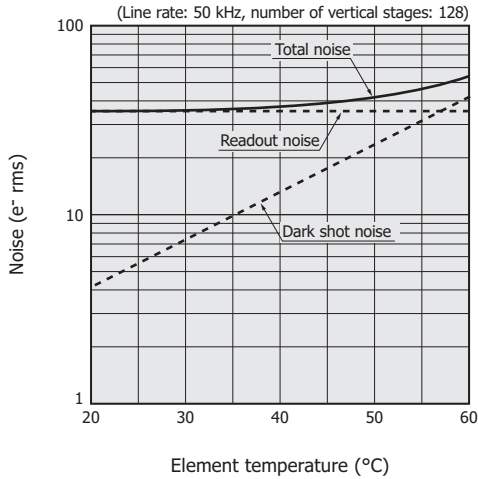

KMPDB0406EA

Heat generation from sensor

The TDI-CCD performs high-speed readout. Because of its multiport structure, the sensor may become hot. Since the dark current increases as the element temperature increases, appropriate heat dissipation measures may be necessary depending on the situation. For the heat dissipation methods, see “Image sensors” under “Precautions.”

The power consumption during charge transfer is proportional to the square of the operating voltage amplitude and readout frequency. In this case, the power consumption by the horizontal shift register whose readout frequency is large is dominant. Therefore, in the horizontal shift register on the side that is not reading out, to reduce heat generation, the drive voltage is set to DC voltage so that unneeded charge is discarded (see the timing chart on the datasheet).

Figure 4-4 is an example showing the relationship between the element temperature and operation time when our evaluation circuit is used (the circuit system is sealed and without any heat dissipation measures).

[Figure 4-4] Element temperature vs. operation time (S10201-04-01, our evaluation circuit, typical example)

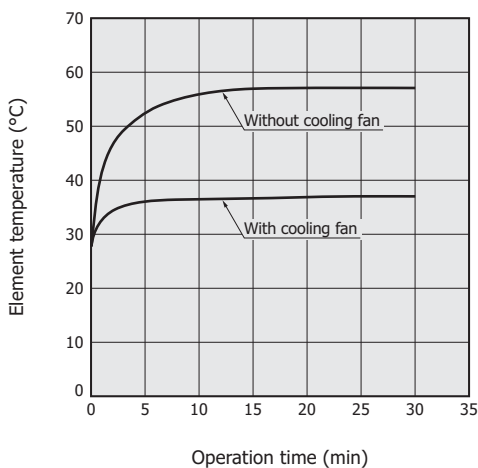

KMPDB0408EA

Clocks and output waveforms during high-speed operation

For the clock waveforms of the horizontal shift register, we recommend that ringing be reduced as much as possible and that the waveforms cross at 50% ± 10% of the clock amplitude [Figure 4-5].

If the drive conditions are not appropriate, saturation charge, CCD transfer efficiency, readout noise, and the like may not meet the characteristic values listed in the datasheet. Furthermore, adjust the waveform applied to the reset gate so that flat regions are created in the OS output waveform’s DC level (reset level) and signal level [Figure 4-6]. The driver circuit requires a mechanism for fine-tuning these clock timings.

[Figure 4-5] Timing chart (horizontal shift register, reset gate)

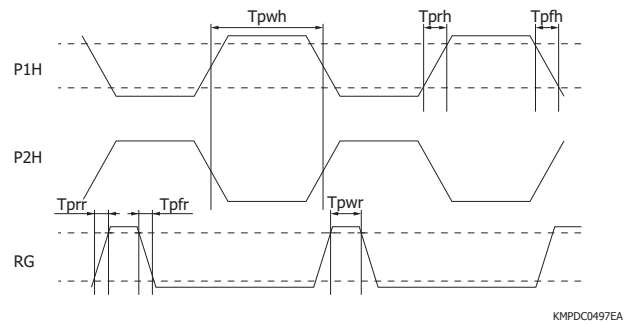

KMPDC0497EA

[Figure 4-6] OS output waveform example

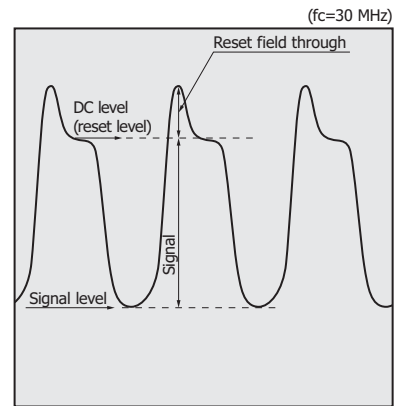

The circuit must be optimized to obtain an ideal waveform as shown above.

KMPDB0409EA

High-speed signal processing circuit

For a CCD signal processing circuit that requires high-speed readout at several megahertz or faster, it is difficult for a circuit constructed only of discrete components to achieve high-speed clamp operation and fast capacitor charging/discharging characteristics.

A high-speed signal processing circuit can be constructed by using an analog front-end IC (a single IC chip consisting of CDS, gain, and offset circuits, A/D converter, etc.) optimized for CCD signal processing [Figure 4-7].

[Figure 4-7] High-speed signal processing circuit example (using analog front-end IC)

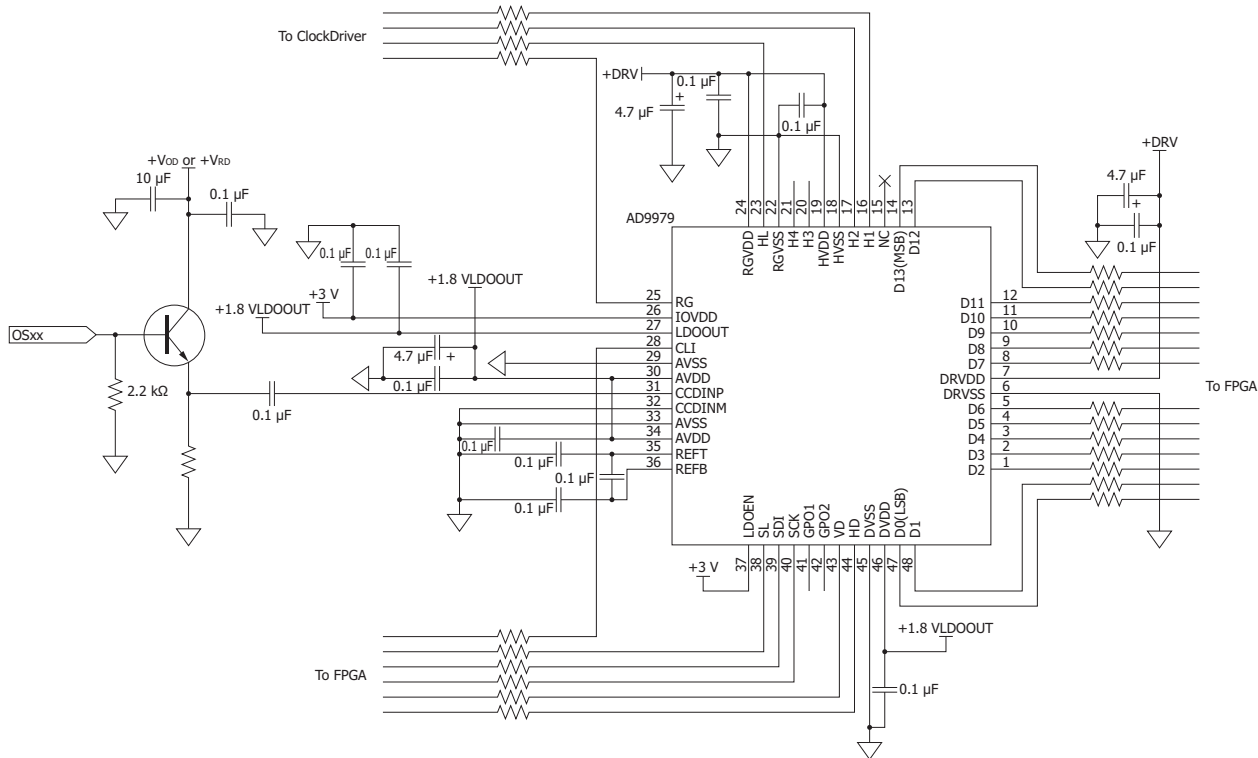

KMPDC0500EA

Readout noise and output signal frequency

In general, lowering the output signal frequency reduces the CCD readout noise [Figure 4-8]. Note that when the output signal frequency is lowered, the line rate is also lowered. This causes an increase in the dark output component during charge transfer, and its shot noise may affect the total noise.

The readout noise varies depending on various factors including the readout circuit.

[Figure 4-8] Readout noise vs. output signal frequency (typical example)

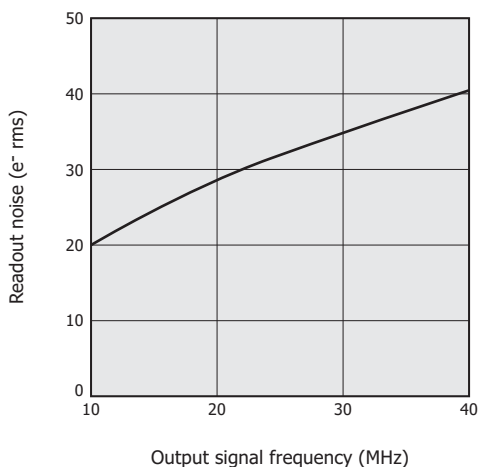

KMPDB0410EA

Exposure adjustment

In TDI operation, the exposure can be varied by changing the line rate. Also, adding a filter to the optical system to adjust the light level is another effective method. Note that our standard products do not have a function for adjusting the exposure by switching the number of vertical stages.

Two-dimensional operation

In addition to TDI operation, Hamamatsu TDI-CCDs can perform two-dimensional operation. This is sometimes used to verify an optical system or for initial evaluation. A two-dimensional operation image when light is incident is shown in Figure 4-9.

A fixed zigzag pattern may appear when the image contrast is enhanced, and the output difference is in the order of a few percent. This is because of the sensitivity difference in each pixel, and the effect varies depending on the wavelength of the incident light. In each column, the composition of pixels of different sensitivities is the same. Therefore, in TDI operation, the average sensitivity of the pixels in each column is the same.

The clock timing chart for two-dimensional operation is shown in Figure 4-10.

(b) Port B readout

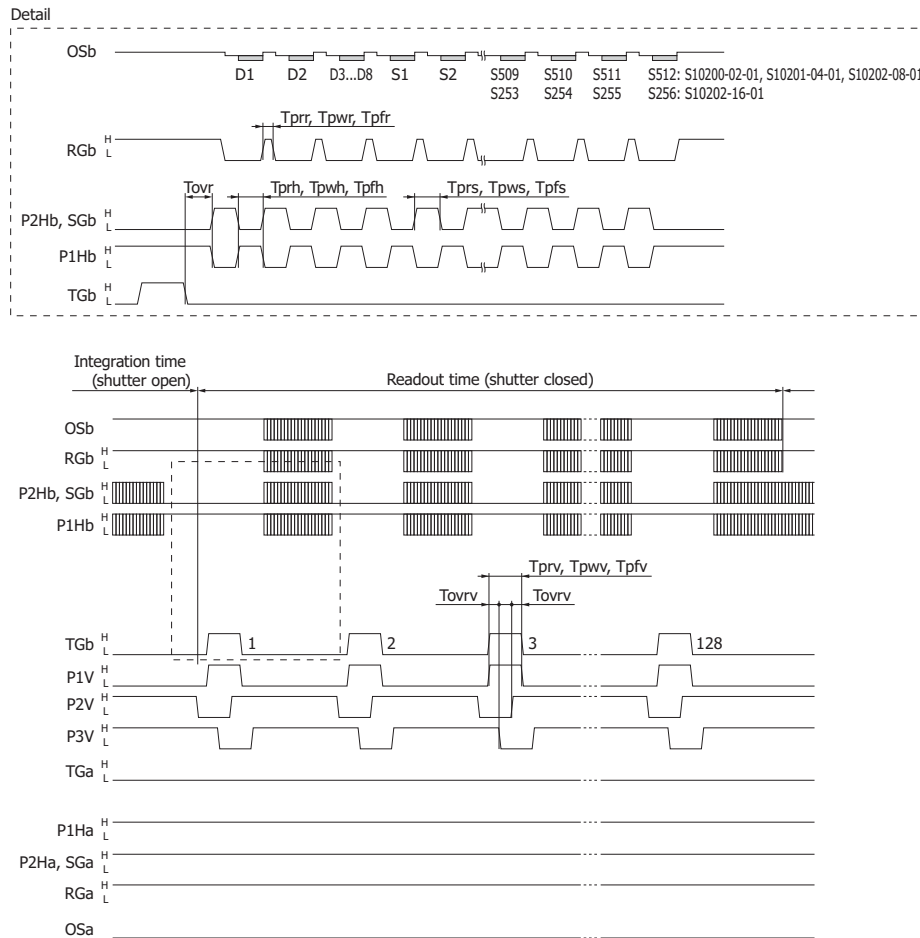

KMPDC0498EB

[Figure 5-1] CCD output section using FDA

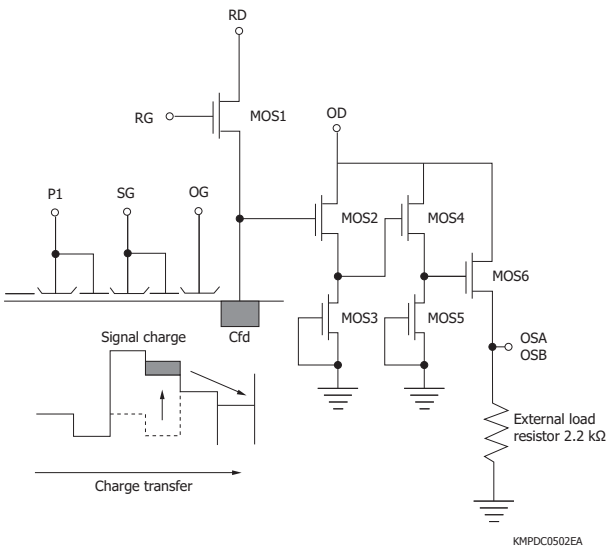

C10000 series TDI camera (related product)

Hamamatsu offers C10000 series TDI cameras with built-in S10201-04-01 back-thinned TDI-CCD and driver circuit.



C10000-801 (built-in S10201-04-01)

Product information

www.hamamatsu.com/all/en/C10000-801.html

Information described in this material is current as of June, 2015.

Product specifications are subject to change without prior notice due to improvements or other reasons. This document has been carefully prepared and the information contained is believed to be accurate. In rare cases, however, there may be inaccuracies such as text errors. Before using these products, always contact us for the delivery specification sheet to check the latest specifications.

Type numbers of products listed in the delivery specification sheets or supplied as samples may have a suffix "(X)" which means preliminary specifications or a suffix "(Z)" which means developmental specifications.

The product warranty is valid for one year after delivery and is limited to product repair or replacement for defects discovered and reported to us within that one year period. However, even if within the warranty period we accept absolutely no liability for any loss caused by natural disasters or improper product use.

Copying or reprinting the contents described in this material in whole or in part is prohibited without our prior permission.

HAMAMATSU

www.hamamatsu.com

HAMAMATSU PHOTONICS K.K., Solid State Division

1126-1 Ichino-cho, Higashi-ku, Hamamatsu City, 435-8558 Japan, Telephone: (81) 53-434-3311, Fax: (81) 53-434-5184

U.S.A.: Hamamatsu Corporation: 360 Foothill Road, Bridgewater, N.J. 08807, U.S.A., Telephone: (1) 908-231-0960, Fax: (1) 908-231-1218

Germany: Hamamatsu Photonics Deutschland GmbH: Arzbergerstr. 10, D-82211 Herrsching am Ammersee, Germany, Telephone: (49) 8152-375-0, Fax: (49) 8152-265-8

France: Hamamatsu Photonics France S.A.R.L.: 19, Rue du Saule Trapu, Parc du Moulin de Massy, 91882 Massy Cedex, France, Telephone: 33-(1) 69 53 71 00, Fax: 33-(1) 69 53 71 10

United Kingdom: Hamamatsu Photonics UK Limited: 2 Howard Court, 10 Tewin Road, Welwyn Garden City, Hertfordshire AL7 1BW, United Kingdom, Telephone: (44) 1707-294888, Fax: (44) 1707-325777

North Europe: Hamamatsu Photonics Norden AB: Torshamnsgatan 35 16440 Kista, Sweden, Telephone: (46) 8-509-031-00, Fax: (46) 8-509-031-01

Italy: Hamamatsu Photonics Italia S.r.l.: Strada della Moia, 1 int. 6, 20020 Arese (Milano), Italy, Telephone: (39) 02-93581733, Fax: (39) 02-93581741

China: Hamamatsu Photonics (China) Co., Ltd.: B1201, Jiaming Center, No.27 Dongsanhuan Beilu, Chaoyang District, Beijing 100020, China, Telephone: (86) 10-6586-6006, Fax: (86) 10-6586-2866