

Time-Resolved Absorption Spectrum Analysis System

Measure the transient absorption spectrum in extremely short time!

Analysis of the formation and decay process of a reactive intermediate in a photoreaction in solutions, solids, membranes, etc are possible.

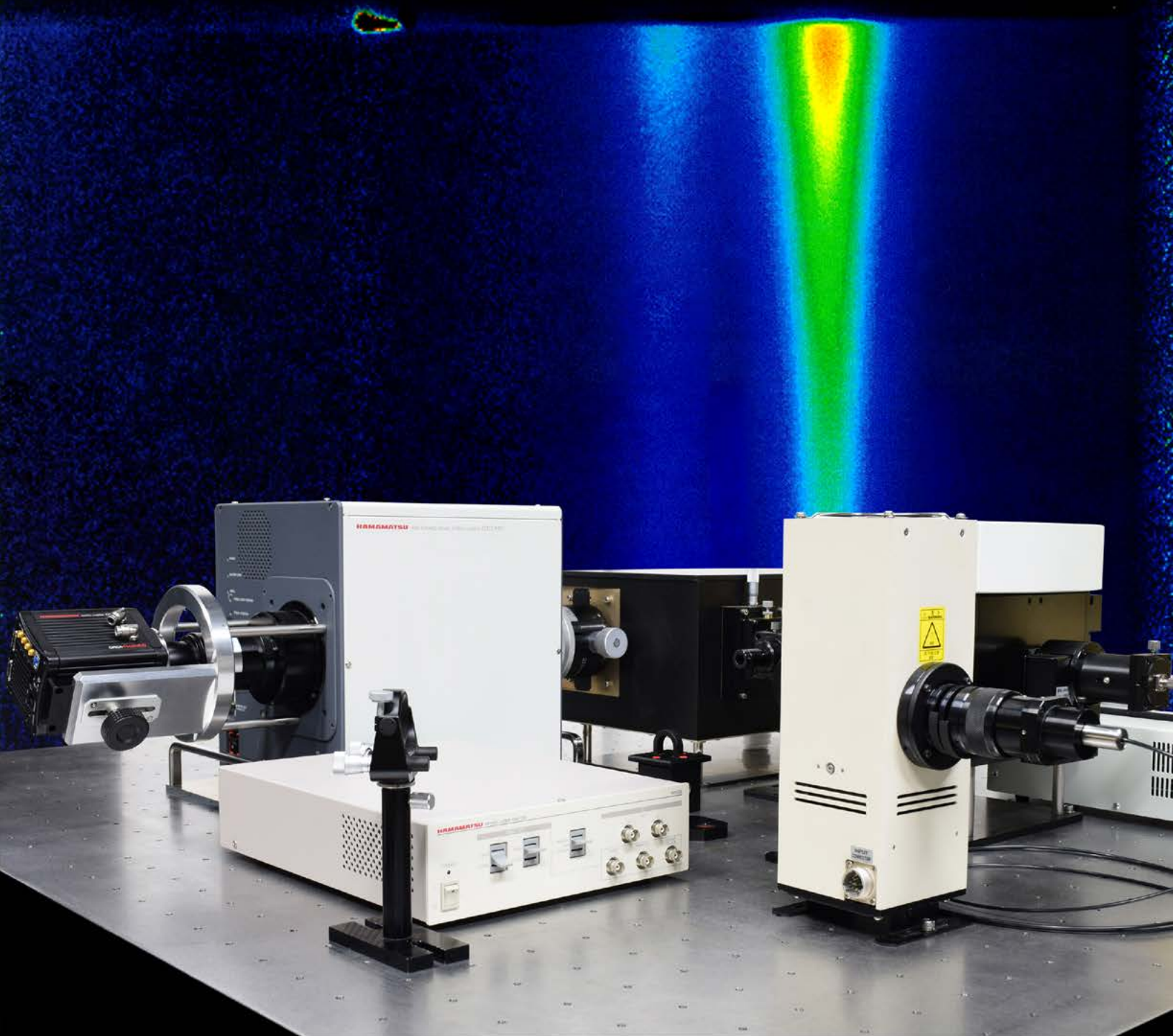

HAMAMATSU
PHOTON IS OUR BUSINESS

Measure the transient absorption spectrum in extremely short time in a high dynamic range with high S/N.



The time-resolved absorption spectrum analysis system is a device to perform transient absorption spectrum measurements in extremely short time. This system enables to analyze the formation and decay process of a reactive intermediate in a photoreaction in solutions, solids, membranes, etc are possible. By using the streak camera as the detector and performing multiple-wavelengths time-resolved measurements with a single shot, time-resolved absorption spectra and transient absorption time-resolved spectral images can be measured simultaneously, and you can obtain images of irreversible phenomenon. The newly developed High dynamic range streak camera C13410 is employed as the detection device. Minute transient absorption changes can also be measured in a high dynamic range with high S/N.

Features

- **Measurements with the smallest optical density (OD) of 0.005 (for single shot, OD value is 0.02 or less)**
- **Simultaneous measurements of multiple wavelengths using a single shot**
- **High time resolution**
- **Automatic measurements with computer control**

System configuration

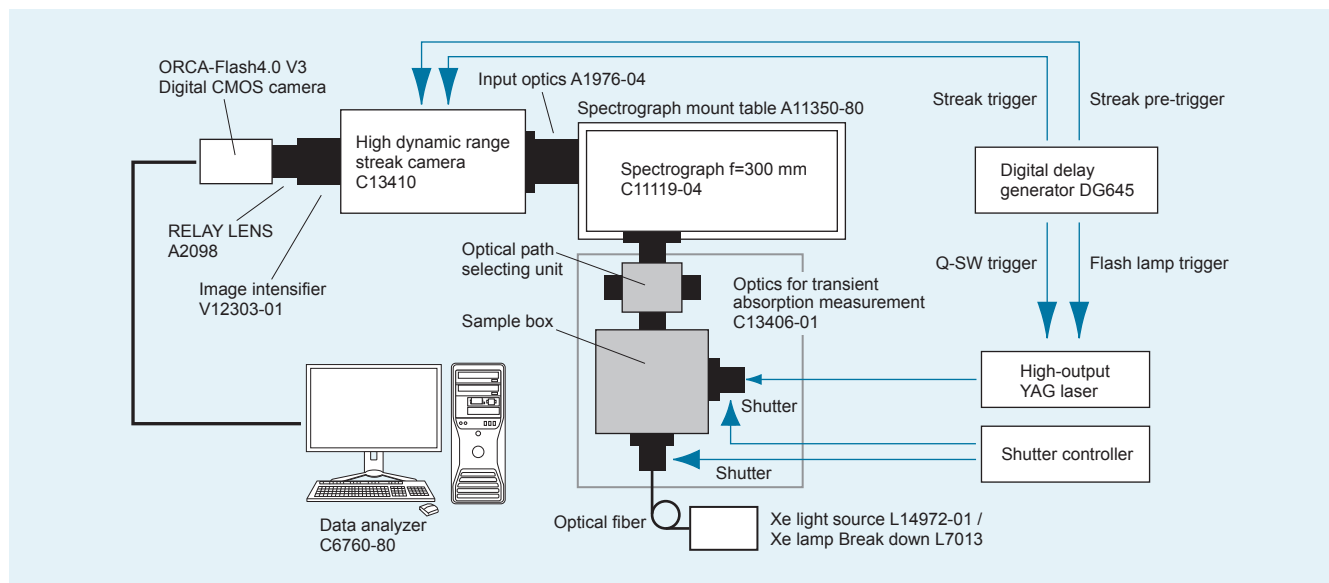

General performance

	Nanosecond Q-SW YAG laser	Picosecond mode-lock YAG laser
Temporal resolution	<7 ns	<70 ps
Measurement time range	20 ns to 1 ms	0.5 ns to 20 ns
White light source	Xe lamp 150 W/CW	Xe lamp Break down
Measurement OD value	0.005 (for single shot, 0.02 or less)	
Simultaneous observation wavelength width (W) and wavelength resolution ($\Delta\lambda$)	100 gr/mm: W= 510 nm, $\Delta\lambda$ <3.0 nm	
	150 gr/mm: W= 340 nm, $\Delta\lambda$ <2.0 nm	
	300 gr/mm: W= 170 nm, $\Delta\lambda$ <1.0 nm	
	600 gr/mm: W= 85 nm, $\Delta\lambda$ <0.5 nm	
Measurement wavelength range	250 nm to 750 nm	
Number of channels	Time axis: 1016 ch Wavelength axis: 1344 ch	

Functions

The time-resolved absorption spectrum analyzing system is composed of a pump and probe lights, optics including shutters (a streak camera transient absorption measurement optical system) a detector part (a spectrograph, a high dynamic range streak camera, and high sensitive digital camera), delay generators, and a data analyzer. For example, a high-output Xenon lamp and a nano-second Q-SW YAG laser are utilized as the pump and probe lights respectively. The pump and probe lights are operated the shutters on the transient absorption measurement software in the data analyzer, and time resolved images such as Data Monitor, (Emission) and Dark images are measured by the detector part. Transient absorption image is obtained from the time-resolved images by calculation with analysis functions.

Control functions

- Streak camera : time range, MCP gain
- Spectrograph : grating selection, central wavelength setting, slit width setting
- Shutter : shutter opening and closing for excitation light and white light, delay generator (delay value setting)

Display functions

- Transient absorption time-resolved spectral images
- Transient absorption time and wavelength profiles

Data storage functions

Live image data (Data, Monitor, Emission1, Emission2, Dark, Absorption1, and Absorption2 from the dialog box), spectrum profiles, and time profiles can be saved as files. This does not include fitting data.

- Image file format : TIFF, ITEX
- Profile file format : TEXT file

Analysis functions

- Analyzing transient absorption operation images
 - For nonfluorescent samples
Absorption1= $-\log_{10} ([Date-Dark]/[Monitor-Dark])$
 - For fluorescent samples
Absorption2= $-\log_{10} ([Date-Emission]/[Monitor-Dark])$
- Analyzing fluorescence images from Emission2
Emission2=Emission1-Dark

Measurement functions

- Data measurements
(The white light is measured with both the pump light and probe light shutters open.)
- Monitor measurements
(The white light is measured with only the probe light shutter open.)
- Emission measurements
(The fluorescence is measured with only the pump light shutter open.)
- Dark measurements
(The dark current is measured with both the pump light and probe light shutters closed.)

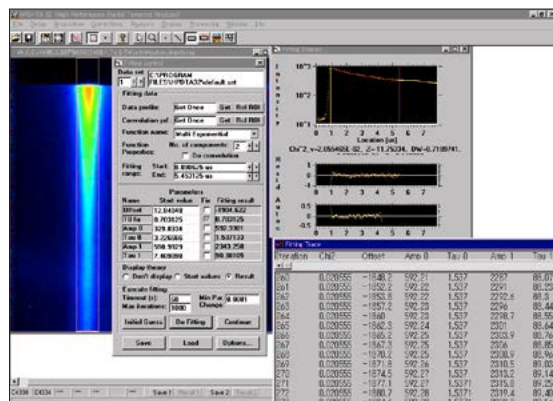

Absorption2
Transient absorption operation image,
example of transient spectrum profile display

Operating principle

Using a streak camera as the detector

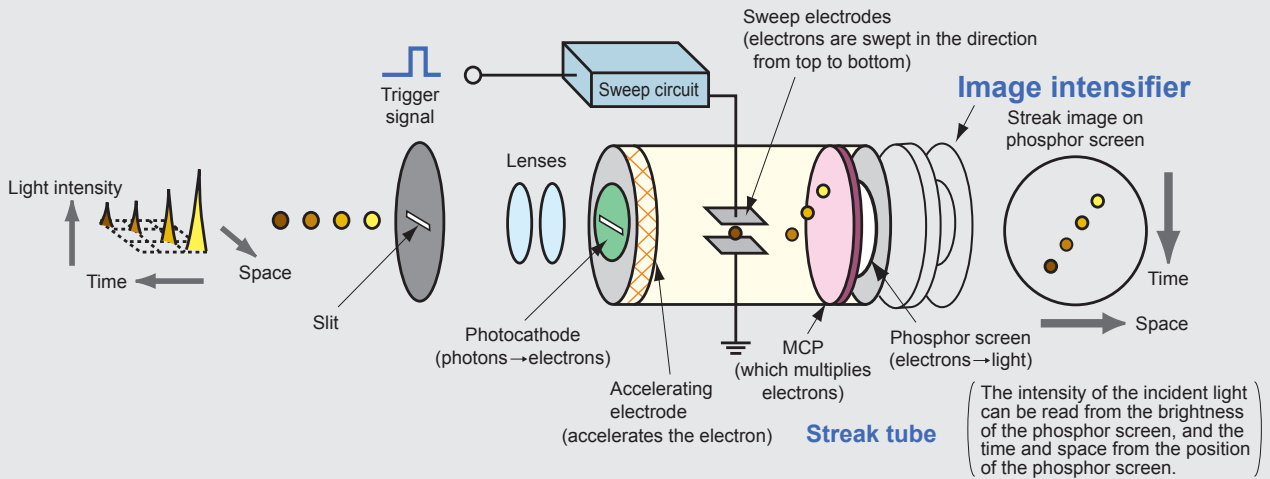

Fig. 1 Operating principle of streak tube

[Streak camera operating principle]

The streak camera is a device that measures and displays the temporal variations of the incident light intensity as the luminance distribution using the positions (spatially) on the screen by converting incident light into electrons and performing a high speed sweep of the electrons from top to bottom. Figure 1 shows the operating principle of the streak tube at the heart of the streak camera.

The light pulse being measured passes through the slit and the lenses and the image of the light is formed as the slit image on the photocathode of the streak tube. Even now, there is a slight lag both temporally and spatially and four light pulses with different light intensities pass through the slit before reaching the photocathode. Because the photocathode also converts the light pulses into electrons proportional to the intensity of the incident light, the four light pulses are converted into electrons in order and accelerated by the accelerating electrode before being conducted towards the phosphor screen. The high-speed sweeping is performed by applying high voltage to the sweep electrodes, timed to the passage between the electrodes of the groups of electrons created from the four light pulses. Because each successive group of electrons arrives a bit later than the previous group, they are deflected at slightly different angles in the perpendicular direction and then bombarded against the phosphor screen where they are converted back into light.

The streak image obtained on the phosphor screen through the image intensifier can be read by a digital camera that has been enhanced for light intensity.

The fluorescence image of the first incident light pulse is positioned at the top of the phosphor screen with successive light pulses appearing lower on the screen in order. In other words, the perpendicular direction on the phosphor screen serves as the time axis. In addition, the brightness of each fluorescence image is proportional to the intensity of the corresponding incident light pulse. The horizontal positions of the fluorescence images correspond to the horizontal positions of the incident light.

Therefore, the spectral images by the spectrograph are formed on the photocathode and the temporal variations in the light intensity that occur in each wavelength can be measured by performing the streak sweep.

[Simultaneous measurements of multiple wavelengths]

As explained in the "Streak camera operating principle" section, time-resolved spectrum measurements of multiple wavelengths can be performed simultaneously by combining the C13410 with the spectrograph. Figure 2 shows an example of a three-dimensional display of time-resolved spectrum photometry.

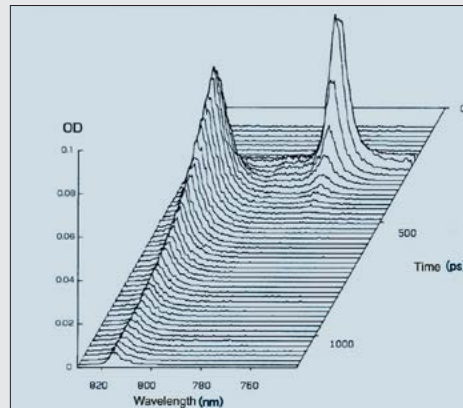
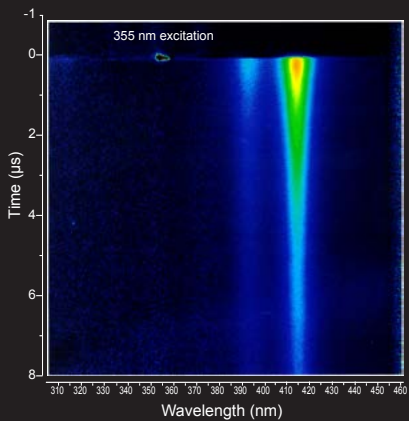

Fig. 2 Example of a three-dimensional display of time-resolved spectrum photometry

Measurement example

Measurement of transient absorption time-resolved spectrum



Time-resolved transient absorption spectral streak image of the triplet-triplet absorption of anthracene in supercritical carbon dioxide (40 °C, 10.9 MPa)

Data courtesy of :
National Institute of Advanced Industrial Science and Technology
Supercritical Fluid Research Center (Sendai City, Japan)
Researcher:
Dr. Takafumi Aizawa

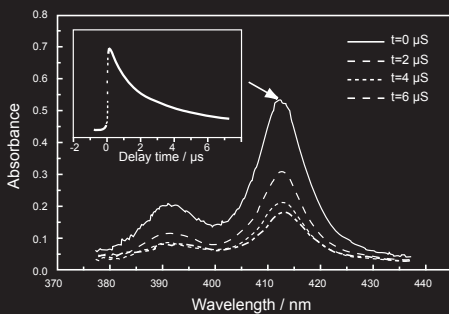

Triplet-triplet absorption spectral of anthracene in supercritical carbon dioxide (40 °C, 10.9 MPa)

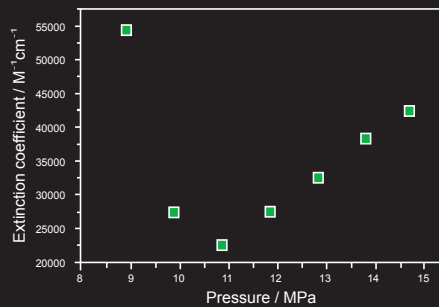

Pressure dependency of the molar extinction coefficient of triplet anthracene (40 °C)

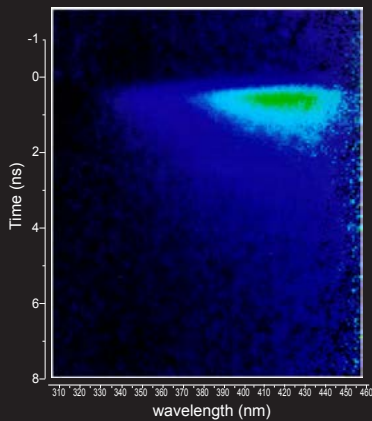

Time-resolved transient absorption spectral streak image of the singlet-singlet absorption of C60

Data courtesy of:
Tohoku University, Institute for Chemical Reaction Science
Professor Osamu Ito

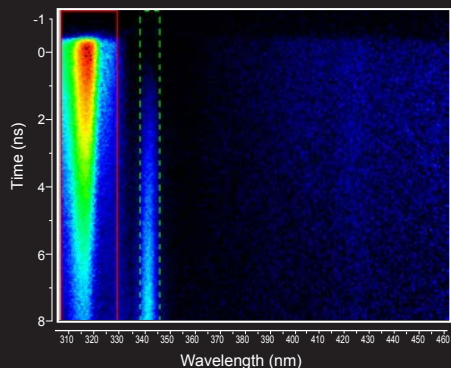

Time-resolved transient absorption spectral streak image in simultaneous observation of the singlet-singlet absorption and the triplet-triplet formation of Anthracene solution

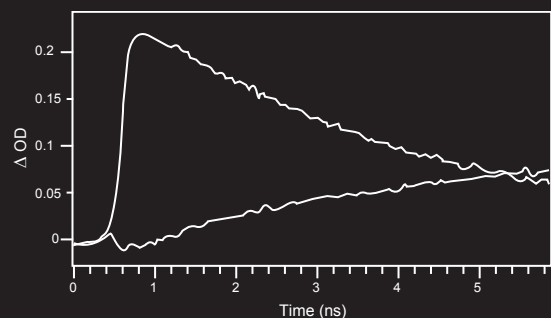

Specifications

High dynamic range streak camera C13410-01A

The streak camera is an ultra high-speed detector with 5 ps temporal resolution. By combining with the spectrograph, transient absorption spectrums can be measured using with a single shot because multiple wavelengths can be observed simultaneously.



Streak tube	Photocathode	S-20
	Spectral response characteristic	200 nm to 850 nm
	Effective photocathode size	7.0 mm (W) × 17.48 mm (L)
	Phosphor screen	P-43, Φ25 mm, Fiberoptic output
	Image enhancement part	Image Intensifier (I.I.) / Image Booster (I.B.) Outside attachment
Main unit	Temporal resolution	Better than 5 ps (at the fastest sweep range)
	Sweep range/full screen 1,2,5 step	0.5 ns to 1 ms
	Trigger jitter	Less than ± 20 ps (at the fastest sweep range)
	Trigger delay	Approx. 30 ns (at the fastest sweep range)
	Maximum sweep repetition frequency	1 kHz at OPEN FIXED mode, 100 Hz at NORMAL mode

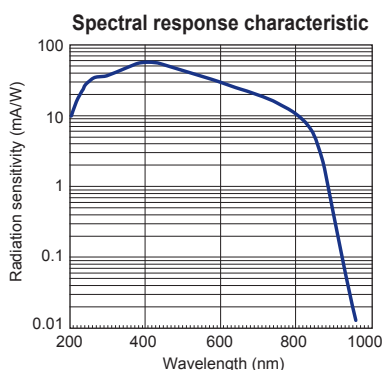

Spectrograph f=300 mm C11119-04

The spectrograph is ideally suited for combination with the streak camera. Since an optical system that corrects for astigmatism is used, the light condensing efficiency at the detector is high and high-sensitivity measurements are possible.



Optical layout	Czerny-Turner model (with toroidal mirror for aberration correction)
Focal distance	300 mm
F value	3.9
Incident light slit width	Variable between 10 μm to 3 mm
Grating	3 (Additional turret/grating available)
Reciprocal dispersion	2.38 nm/mm (when using 1200 gr/mm)

● Gratings (typical examples)

No. of grooves	Blaze wavelength	Wavelength range	Measurement wavelength range	resolution
100 gr/mm	450 nm	300 nm to 700 nm	Approx. 510 nm	< 3.0 nm
150 gr/mm	500 nm	335 nm to 750 nm	Approx. 340 nm	< 2.0 nm
300 gr/mm	500 nm	335 nm to 750 nm	Approx. 170 nm	< 1.0 nm
600 gr/mm	500 nm	335 nm to 750 nm	Approx. 85 nm	< 0.5 nm

Spectrograph mount table A11350-80

The spectrograph mount table is a support stand for connecting and fixing the spectrograph and streak camera.

Optics for transient absorption measurement C13406-01

The optics for transient absorption measurement contains 3 kinds of optics: a white light input optics, an excitation optics, and 2 optical laser shutters.

Measurements can be performed accurately in the 250 nm to 750 nm measurement wavelength range. Excitation optics is composed of 2 triple wavelength YAG laser mirrors for 532 nm, 355 nm, and 266 nm laser lines.

Measurement wavelength range	250 nm to 750 nm
Laser mirror	Dielectric multilayer mirror (for 532 nm, 355 nm, 266 nm)
Sample holder	10 mm cell holder, Thin film sample holder
Laser shutter (A6538)	Rotating solenoid, 2 heads (1 for pump light / 1 for probe light)

ORCA-Flash4.0 V3 Digital CMOS camera C13440-20CU

Recommended readout camera for universal applications, including single-shot, analog and photon counting integration.



Effective number of pixels	2048 (H) × 2048 (V)
Working area	1344 (H) × 1016 (V)
Cell size	6.5 μm (H) × 6.5 μm (V)
Effective area	13.312 mm (H) × 13.312 mm (V)
Frame rate	100 frames/s Standard scan (Full resolution, Camera Link)
Working area on phosphor screen	12.48 mm (H) × 9.43 mm (V)
Exposure time	1 ms to 10 s Standard scan Internal trigger mode with Full resolution
Digital output	16 bit

Digital delay generator DG645 C13430-02

The DG645 is a general-purpose delay generator that matches the streak camera timing with the pulsed laser timing, mainly for slower streak times.



Number of output channels	4 ch (AB, CD, EF, GH output terminal)
Output level	0.5 V to 5.0 V 50 Ω
Variable delay range	0 ps to 2000 s
Delay resolution	5 ps
Internal delay time	85 ns
Repetition rate	Single to 10 MHz
Jitter	< 25 ps rms
Interface	GPIO/RS-232C

Delay unit C1097-05

The delay unit is used to adjust the operation timing of streak camera with the laser pulse.

Delay range	31.75 ns
Delay setting range	30 ps, 60 ps, 120 ps, 250 ps, 500 ps, 1 ns, 2 ns, 4 ns, 8 ns, 16 ns



Xe light source L14972-01

The Xe light source is a highly stable white light source without shaking or movement at the source of the arc light.

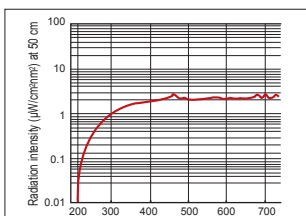

Radiation wavelength	220 nm to 2000 nm
Radiation intensity	250 nm : 0.52 µW/cm ² · nm ⁻¹ at 50 cm 500 nm : 2.00 µW/cm ² · nm ⁻¹ at 50 cm
Power consumption	150 W
Window material	Ozoneless quartz
Light output stability	Drift : ± 0.5 %/h (typ.) Fluctuation : 1.0 % (Max.)

Image intensifier V12303-01

The image intensifier is an option to enhance the streak image at the phosphor screen of the streak tube 1000 times and output it.



Photoelectric surface	Bialkali
Luminance gain	1000 (Max.)
MCP	Built-in

Data analyzer C6760-80

The data analyzer is used to control each device such as the streak camera and spectrograph and to collect and analyze data.

Supported camera	ORCA-Flash4.0 V3 Digital CMOS camera C13440-20CU
Component	Computer set Software HPD-TA + Ta-Abs Frame grabber board DIO board External trigger cable Shutter cable Camera Link cable
System	Windows 10 Pro, 64 bit
Interface	Camera Link

<Control & readout software HPD-TA>

Data acquisition	Live mode, analog integration mode photon counting mode, sequence recording mode
Device control	Streak camera, reabout camera, spectrograph, delay units
Profile function	Real-time display, min/max, FWHM, Gauss fit
Data corrections	Background, sensitivity, curvature, Jitter
Axis calibration	Channel, time, wavelength
File formats (images)	Binary (up to 32 bit), TIFF, ASCII
File formats (profiles)	ASCII

Xe lamp Break down L7013

The Xe lamp Break down can generate extremely bright white light from 250 nm to 750 nm with 50 ns pulse width (FWHM) by focusing the fundamental wavelength (1064 nm) of the high output picosecond laser onto the Xe cell.



This is different from ordinary pulse xenon lamps and allows you to obtain smooth spectra without bright lines. By combining with a high-output picosecond laser, transient absorption measurements are possible in the picosecond region.

Emission wavelength range	250 nm to 750 nm
Emission time width	Approx. 50 ns (FWHM)
Stability	OD corresponding value less than ± 0.005 ^①
Noise	OD corresponding value less than ± 0.02 ^②

① This is the baseline shaking when the absorption operation is performed and was determined from two single shot measurements of the white light output when a 20 mJ/pulse YAG laser light was directed at the L7013.

② This is the noise level when the absorption operation is performed and was determined from a single shot measurement of the white light under the same conditions as in.

Excitation light source

The YAG laser is the excitation light source for transient absorption measurements. The system can be enhanced by combining with the lasers from various manufacturers.

Laser handling mirror for T-Absorption A8005 (optional)

The laser handling mirror is used to direct the YAG laser in the optical system.

Coating	Dielectric multilayer film mirror
Reflection wavelength	1.06 µm, 532 nm, 355 nm, and 266 nm

Coaxial excitation optics (optional)

This is an optical system to excite the excitation light on the same axis as the white light. The excitation light is reflected by the dichroic mirror and is directed at the sample on the same axis. This excitation light is removed by the color filter installed after the sample. This optical system is used to perform transient absorption measurements of solution samples, film, and membrane samples in a cell with a 2 mm optical path length.

Dimensional outlines (Unit: mm)

● **High dynamic range streak camera C13410-01A (Approx. 26 kg Main unit only)**

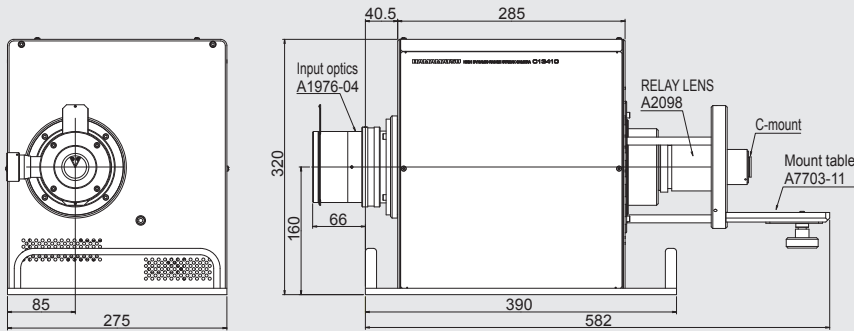

● **Spectrograph f=300 mm C11119-04 (Approx. 16 kg)**

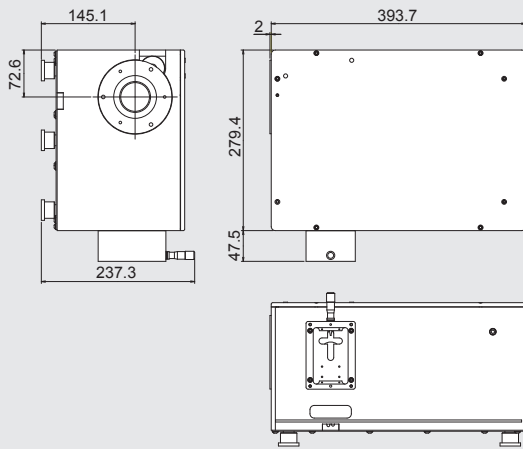

● **ORCA-Flash4.0 V3 Digital CMOS camera C13440-20CU (Approx. 2.2 kg)**

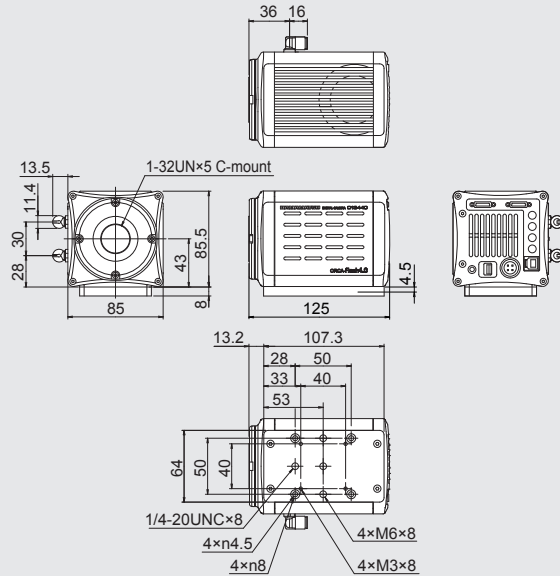

- ORCA is registered a trademark of Hamamatsu Photonics K.K.
 - Product and software package names noted in this documentation are trademarks or registered trademarks of their respective manufacturers.
 - The university, institute, or company name of the researchers, whose measurement data is published in this brochure, is subject to change.
 - Subject to local technical requirements and regulations, availability of products included in this promotional material may vary. Please consult your local sales representative.
 - Information furnished by HAMAMATSU is believed to be reliable. However, no responsibility is assumed for possible inaccuracies or omissions.
- Specifications and external appearance are subject to change without notice.

© 2018 Hamamatsu Photonics K.K.

HAMAMATSU PHOTONICS K.K. www.hamamatsu.com

HAMAMATSU PHOTONICS K.K., Systems Division

812 Joko-cho, Higashi-ku, Hamamatsu City, 431-3196, Japan, Telephone: (81)53-431-0124, Fax: (81)53-433-8031, E-mail: export@sys.hpk.co.jp

U.S.A.: Hamamatsu Corporation: 360 Foothill Road, Bridgewater, NJ 08807, U.S.A., Telephone: (1)908-231-0960, Fax: (1)908-231-1218 E-mail: usa@hamamatsu.com

Germany: Hamamatsu Photonics Deutschland GmbH: Arzbergerstr. 10, D-82211 Herrsching am Ammersee, Germany, Telephone: (49)8152-375-0, Fax: (49)8152-265-8 E-mail: info@hamamatsu.de

France: Hamamatsu Photonics France S.A.R.L.: 19, Rue du Saule Trapu, Parc du Moulin de Massy, 91882 Massy Cedex, France, Telephone: (33)1 69 53 71 00, Fax: (33)1 69 53 71 10 E-mail: infos@hamamatsu.fr

United Kingdom: Hamamatsu Photonics UK Limited: 2 Howard Court, 10 Tewin Road, Welwyn Garden City, Hertfordshire AL7 1BW, UK, Telephone: (44)1707-294888, Fax: (44)1707-325777 E-mail: info@hamamatsu.co.uk

North Europe: Hamamatsu Photonics Norden AB: Torshamnsgatan 35 16440 Kista, Sweden, Telephone: (46)8-509 031 00, Fax: (46)8-509 031 01 E-mail: info@hamamatsu.se

Italy: Hamamatsu Photonics Italia S.r.l.: Strada della Moia, 1 int. 6, 20020 Arese (Milano), Italy, Telephone: (39)02-93 58 17 33, Fax: (39)02-93 58 17 41 E-mail: info@hamamatsu.it

China: Hamamatsu Photonics (China) Co., Ltd.: 1201 Tower B, Jiaming Center, 27 Dongsanhuan Beilu, Chaoyang District, 100020 Beijing, China, Telephone: (86)10-6586-6006, Fax: (86)10-6586-2866 E-mail: hpc@hamamatsu.com.cn

Taiwan: Hamamatsu Photonics Taiwan Co., Ltd.: 8F-3, No.158, Section2, Gongdao 5th Road, East District, Hsinchu, 300, Taiwan R.O.C. Telephone: (886)03-659-0080, Fax: (886)03-659-0081 E-mail: info@hamamatsu.com.tw

Cat. No. SHSS0005E05
DEC/2018 HPK
Created in Japan