

J12853



Substrate that enhances the weak Raman scattered light from the molecules

The surface-enhanced Raman spectroscopy (SERS) substrate enhances the Raman scattering light from molecules, making high-sensitive Raman spectroscopic analysis possible. A chip of metallic nano/sub-micro structure is mounted on Hamamatsu's original handling plate to protect its active area. The active area of the handling plate is of a well structure for easily attaching solution or the like. It is noted this is a disposable product and cannot be reused.

Features

- Uniform activated surface structure
- Handling plate that protects the active area
- Well structure to facilitate attaching solution or the like

Applications

- Chemical analysis (e.g., molecule type and structure)
- Environmental measurement (e.g., water quality, pesticides, toxic substance)
- Biological measurements (biomolecules of protein, saccharides, etc.)

SERS

SERS is a method for enhancing Raman scattering light (Raman scattering light is typically weak.). The scattering light generated on incidence to molecules is mainly scattering light (Rayleigh scattering light) of a wavelength common to that of the incident light. In addition to the Rayleigh scattering light, a faint amount of the scattering light (Raman scattering light) of wavelengths different from that of the incident light is emitted. The difference (Raman shift) in the frequencies between the incident light and the Raman scattering light comes from the natural frequencies of the molecules. Spectrometry of the Raman scattering light reveals information about a type and a structure of the molecule (type of chemical bond, level of crystallization, distortion of crystal lattice, etc.). For example, glucose and galactose are isomers that have nearly the same chemical structures, but they can be distinguished by Raman spectroscopic analysis.

The enhancement of the faint Raman scattering light by the SERS substrate facilitates spectrometry. When a minute metal (Au) structure formed by nanoimprint technology is exposed to light, and interaction (surface plasmon resonance) occurs between the light and the electrons of the metal surface, creating an enhanced electric field. This effect enhances the Raman scattering light of the molecules that are close or attached to the metal surface.

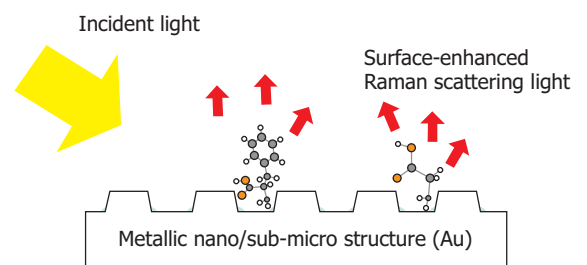

KOTHC0080EA

Notice

- Do not apply shock or pressure anywhere on the substrate.
 - This is a disposable product and cannot be reused.
 - Recommended storage temperature: 4 to 25 °C (unopened condition)
 - The expiration date is indicated on the packing. Do not use the product after the expiration date.
- Note: The expiration date is 3 months after the shipping date on the packing.

Specifications (typical values)

Parameter	Specification	Unit
Substrate size	76 × 26 × 3.6	mm
Chip size	4 × 4	mm
Active area	2.7 × 2.7	mm
Well capacity	6	μL
Activated surface structure	Au nanostructure	-
Handling plate material	Polypropylene	-
Raman excitation wavelength (recommended)	785	nm

Dimensional outline (unit: mm)

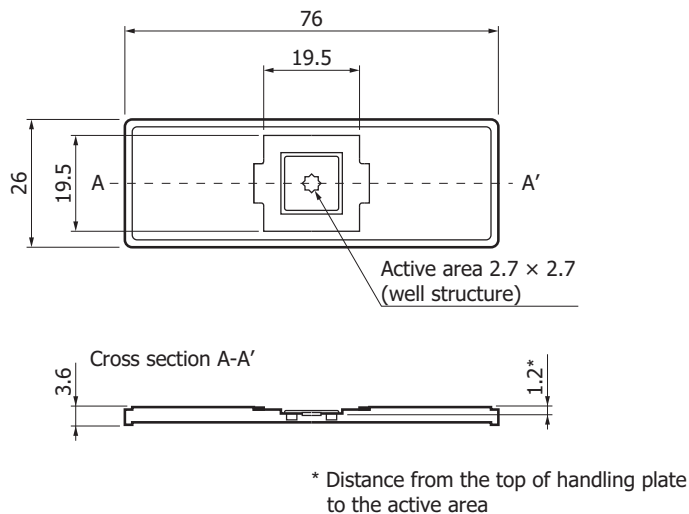

KOTH40006EA

Example of Raman spectrum

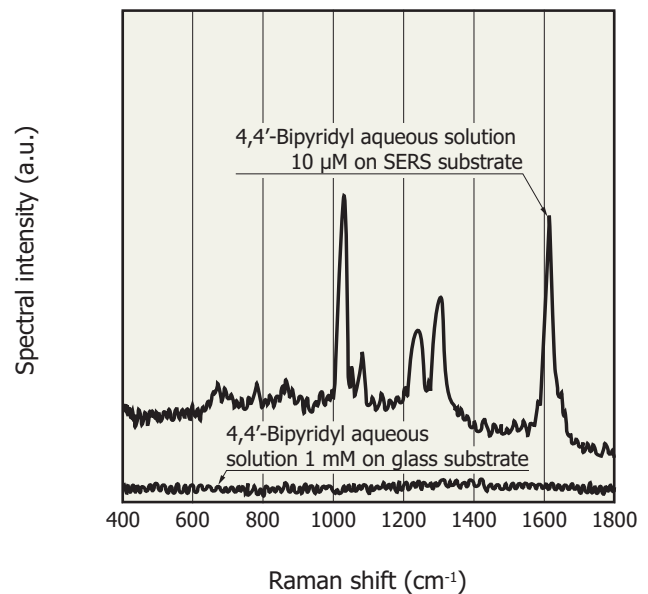

KOTH80035EA

Information described in this material is current as of February 2020.

Product specifications are subject to change without prior notice due to improvements or other reasons. This document has been carefully prepared and the information contained is believed to be accurate. In rare cases, however, there may be inaccuracies such as text errors. Before using these products, always contact us for the delivery specification sheet to check the latest specifications.

The product warranty is valid for three months after delivery and is limited to product repair or replacement for defects discovered and reported to us within that three-month period. However, even if within the warranty period we accept absolutely no liability for any loss caused by natural disasters or improper product use. Copying or reprinting the contents described in this material in whole or in part is prohibited without our prior permission.

HAMAMATSU

www.hamamatsu.com

HAMAMATSU PHOTONICS K.K., Solid State Division

1126-1 Ichino-cho, Higashi-ku, Hamamatsu City, 435-8558 Japan, Telephone: (81)53-434-3311, Fax: (81)53-434-5184

U.S.A.: Hamamatsu Corporation: 360 Foothill Road, Bridgewater, N.J. 08807, U.S.A., Telephone: (1)908-231-0960, Fax: (1)908-231-1218, E-mail: usa@hamamatsu.com

Germany: Hamamatsu Photonics Deutschland GmbH: Arzbergerstr. 10, D-82211 Herrsching am Ammersee, Germany, Telephone: (49)8152-375-0, Fax: (49)8152-265-8, E-mail: info@hamamatsu.de

France: Hamamatsu Photonics France S.A.R.L.: 19, Rue du Saule Trapu, Parc du Moulin de Massy, 91882 Massy Cedex, France, Telephone: (33)1 69 53 71 00, Fax: (33)1 69 53 71 10, E-mail: infos@hamamatsu.fr

United Kingdom: Hamamatsu Photonics UK Limited: 2 Howard Court, 10 Tewin Road, Welwyn Garden City, Hertfordshire AL7 1BW, United Kingdom, Telephone: (44)1707-294888, Fax: (44)1707-325777, E-mail: info@hamamatsu.co.uk

North Europe: Hamamatsu Photonics Norden AB: Torshamnsgatan 35 16440 Kista, Sweden, Telephone: (46)8-509 031 00, Fax: (46)8-509 031 01, E-mail: info@hamamatsu.se

Italy: Hamamatsu Photonics Italia S.r.l.: Strada della Moia, 1 int. 6, 20020 Arese (Milano), Italy, Telephone: (39)02-93 58 17 33, Fax: (39)02-93 58 17 41, E-mail: info@hamamatsu.it

China: Hamamatsu Photonics (China) Co., Ltd.: B1201, Jiaming Center, No.27 Dongsanhuan Beilu, Chaoyang District, 100020 Beijing, P.R.China, Telephone: (86)10-6586-6006, Fax: (86)10-6586-2866, E-mail: hpc@hamamatsu.com.cn

Taiwan: Hamamatsu Photonics Taiwan Co., Ltd.: 8F-3, No. 158, Section2, Gongdao 5th Road, East District, Hsinchu, 300, Taiwan R.O.C. Telephone: (886)3-659-0080, Fax: (886)3-659-0081, E-mail: info@hamamatsu.com.tw