

Type II superlattice infrared detector



P15409-901

High sensitivity and high-speed response infrared detector with sensitivity in the 14 μm band

P15409-901 is a Type II superlattice infrared detector with a sensitivity extended to 14 μm band using Hamamatsu unique crystal growth technology and process technology. This product is environmentally friendly infrared detector and does not use mercury or cadmium, which are substances restricted by the RoHS Directive. It is a replacements for conventional products containing these substances.

Feature

- High sensitivity
- High-speed response
- Excellent linearity

Applications

- FTIR
- Gas detection
- Radiation thermometers

Option (sold separately)

- Amplifier for infrared detector **C4159-01**

Structure

Parameter	Specification	Unit
Window material	ZnSe	-
Package	Metal dewar	-
Cooling	Liquid nitrogen	-
Photosensitive area	φ0.1	mm

Absolute maximum ratings

Parameter	Symbol	Value	Unit
Reverse voltage	VR	0.1	V
Operating temperature*1	Topr	-40 to +60	°C
Storage temperature*1	Tstg	-55 to +60	°C

*1: No dew condensation

When there is a temperature difference between a product and the surrounding area in high humidity environment, dew condensation may occur on the product surface. Dew condensation may cause deterioration in characteristics and reliability.

Note: Exceeding the absolute maximum ratings even momentarily may cause a drop in product quality. Always be sure to use the product within the absolute maximum ratings.

Electrical and optical characteristics (Tchip=-196 °C)

Parameter	Symbol	Condition	Min.	Typ.	Max.	Unit
Peak sensitivity wavelength	λ_p		-	5.4	-	μm
Cutoff wavelength*2	λ_c		-	14.5	-	μm
Photosensitivity	S	$\lambda=\lambda_p$	-	2.6	-	A/W
Shunt resistance	Rsh	$V_R=10\text{ mV}$	-	2.5	-	k Ω
Terminal capacitance	Ct	$V_R=0\text{ V}, f=1\text{ MHz}$	-	50	-	pF
Detectivity	D*	($\lambda_p, 1200, 1$)	5.0×10^9	1.6×10^{10}	-	$\text{cm}^2\text{Hz}^{1/2}/\text{W}$
Noise equivalent power	NEP	$\lambda=\lambda_p$	-	5.5×10^{-12}	1.8×10^{-11}	$\text{W}/\text{Hz}^{1/2}$
Rise time	tr	$V_R=0\text{ V}, R_L=50\ \Omega,$ 0 to 63%	-	150	-	ns

*2: Wavelength at which signal/noise=1

Spectral response (D*)

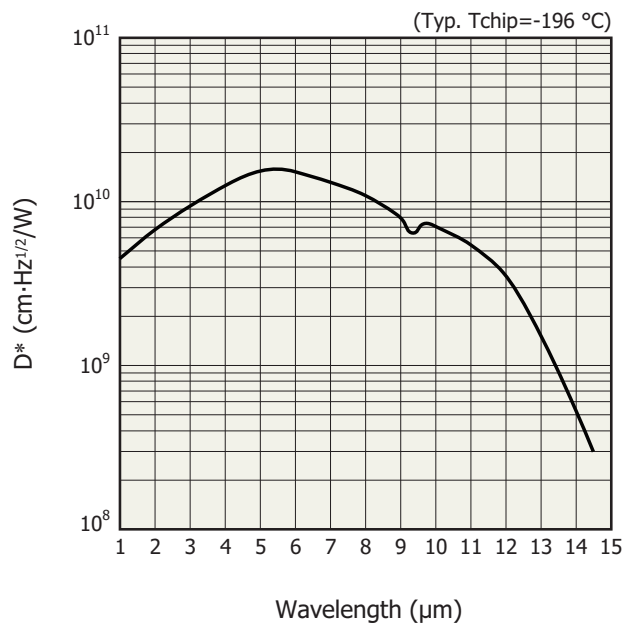

KIRD80673EB

Linearity

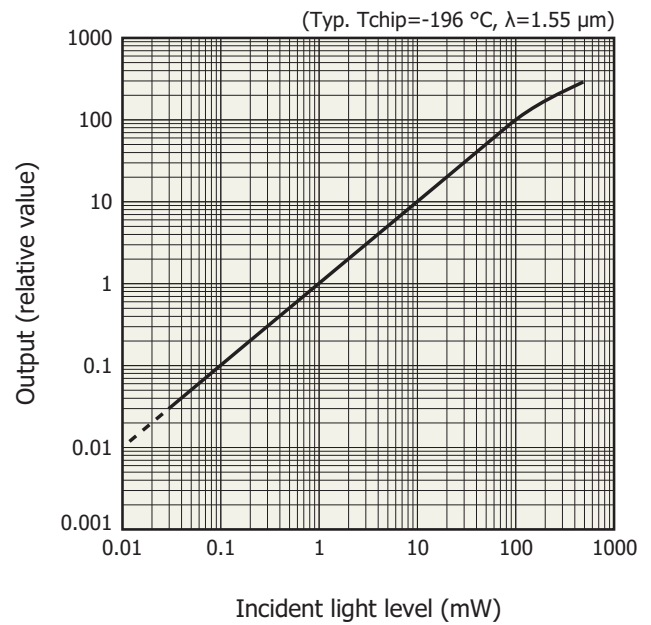

KIRD80677EA

Measurement circuit example

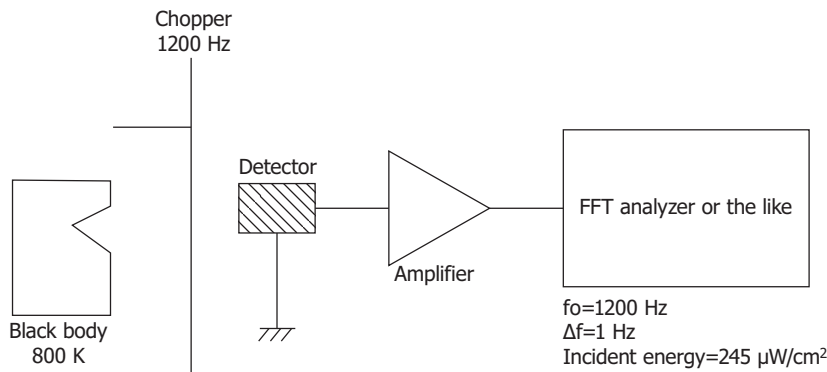

KIRDC0127EA

Dimensional outline (unit: mm)

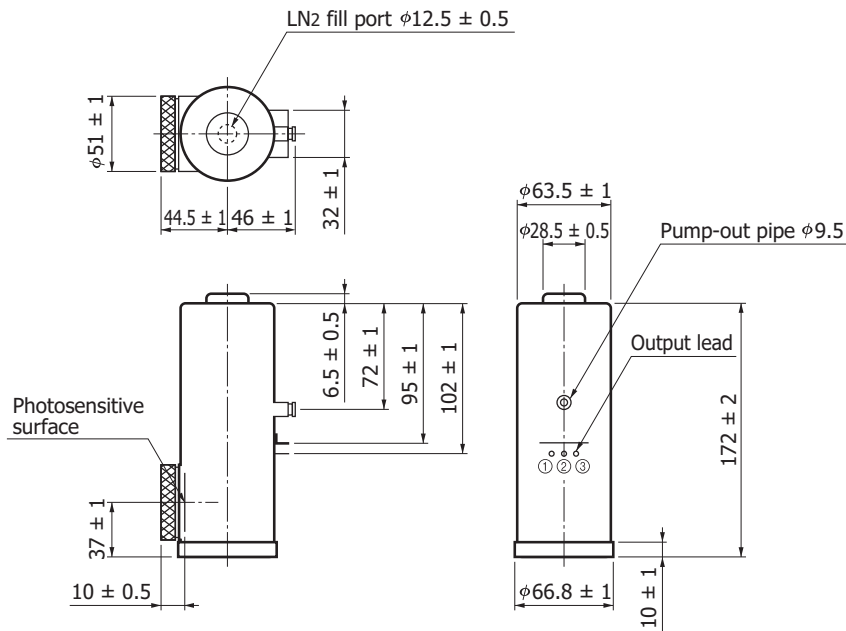

- ① Detector (anode)
- ② NC
- ③ Detector (cathode)

KIRDA0190ED

Related information

www.hamamatsu.com/sp/ssd/doc_en.html

- Precautions
- Disclaimer

Information described in this material is current as of September 2019.

Product specifications are subject to change without prior notice due to improvements or other reasons. This document has been carefully prepared and the information contained is believed to be accurate. In rare cases, however, there may be inaccuracies such as text errors. Before using these products, always contact us for the delivery specification sheet to check the latest specifications.

The product warranty is valid for one year after delivery and is limited to product repair or replacement for defects discovered and reported to us within that one year period. However, even if within the warranty period we accept absolutely no liability for any loss caused by natural disasters or improper product use. Copying or reprinting the contents described in this material in whole or in part is prohibited without our prior permission.

HAMAMATSU

www.hamamatsu.com

HAMAMATSU PHOTONICS K.K., Solid State Division

1126-1 Ichino-cho, Higashi-ku, Hamamatsu City, 435-8558 Japan, Telephone: (81)53-434-3311, Fax: (81)53-434-5184

U.S.A.: Hamamatsu Corporation: 360 Foothill Road, Bridgewater, N.J. 08807, U.S.A., Telephone: (1)908-231-0960, Fax: (1)908-231-1218, E-mail: usa@hamamatsu.com

Germany: Hamamatsu Photonics Deutschland GmbH: Arzbergerstr. 10, D-82211 Herrsching am Ammersee, Germany, Telephone: (49)8152-375-0, Fax: (49)8152-265-8, E-mail: info@hamamatsu.de

France: Hamamatsu Photonics France S.A.R.L.: 19, Rue du Saule Trapu, Parc du Moulin de Massy, 91882 Massy Cedex, France, Telephone: (33)1 69 53 71 00, Fax: (33)1 69 53 71 10, E-mail: infos@hamamatsu.fr

United Kingdom: Hamamatsu Photonics UK Limited: 2 Howard Court, 10 Tewin Road, Welwyn Garden City, Hertfordshire AL7 1BW, United Kingdom, Telephone: (44)1707-294888, Fax: (44)1707-325777, E-mail: info@hamamatsu.co.uk

North Europe: Hamamatsu Photonics Norden AB: Torshamnsgatan 35 16440 Kista, Sweden, Telephone: (46)8-509 031 00, Fax: (46)8-509 031 01, E-mail: info@hamamatsu.se

Italy: Hamamatsu Photonics Italia S.r.l.: Strada della Moia, 1 int. 6, 20020 Arese (Milano), Italy, Telephone: (39)02-93 58 17 33, Fax: (39)02-93 58 17 41, E-mail: info@hamamatsu.it

China: Hamamatsu Photonics (China) Co., Ltd.: B1201, Jiaming Center, No.27 Dongsanhuan Beilu, Chaoyang District, 100020 Beijing, P.R.China, Telephone: (86)10-6586-6006, Fax: (86)10-6586-2866, E-mail: hpc@hamamatsu.com.cn

Taiwan: Hamamatsu Photonics Taiwan Co., Ltd.: 8F-3, No. 158, Section2, Gongdao 5th Road, East District, Hsinchu, 300, Taiwan R.O.C. Telephone: (886)3-659-0080, Fax: (886)3-659-0081, E-mail: info@hamamatsu.com.tw