

Radiation detection modules

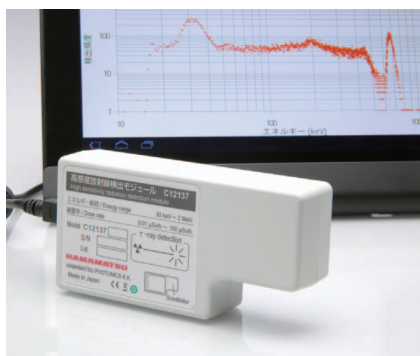

C12137 series

High accuracy, high sensitivity, compact radiation detection module

The C12137 series is a radiation detection module containing a scintillator and MPPC® (multi-pixel photon counter) designed to detect gamma rays from ¹³⁷Cs (Cesium-137) and the like. The scintillator converts incident gamma rays into visible light, and the MPPC detects the light down to extremely low light levels to measure low-energy gamma rays with high accuracy. The signal processing circuit and A/D converter are housed in a compact case. The modules provide a USB or RS-232C interface. The products include sample software with functions for setting measurement conditions, acquiring and saving data, and drawing graphs, etc.

Features

- Gamma ray energy discrimination
- Modular design for easy integration into devices
- Compact and lightweight

Applications

- Environmental monitoring and mapping
- Screening such as incoming and outgoing inspections at manufacturing sites
- Incorporation into portable, high-sensitivity detectors

Lineup

A total of eight types in four different sizes and two interfaces (USB and RS-232C) are available that you can choose from according to your application.

* The characteristics are the same between the USB type and RS-232C type (the software specifications are different).



Structure

USB type					
Parameter	C12137	C12137-01	C12137-08	C12137-10	Unit
Dimensions (W × D × H)	110 × 55 × 27	71 × 55 × 60.5	112 × 94 × 53.3	122 × 122 × 53.3	mm
Weight	120	320	1130	1570	g
Detector	MPPC				-
Scintillator	CsI (TI)				-
Scintillator size (W × D × H)	13 × 13 × 20	38 × 38 × 25	80 × 80 × 25	φ110 × 25	mm
Sampling time	0.1 to 60 s, adjustable				-
Interface	USB 2.0 (Full Speed)				-
Compatible OS	Windows 7 SP1 (32-bit, 64-bit)				-
Power supply	USB bus power (150 mA typ., 500 mA max.)				-

RS-232C type

Parameter	C12137-00D	C12137-01D	C12137-08D	C12137-10D	Unit
Dimensions (W × D × H)*1	110 × 55 × 27	71 × 55 × 60.5	112 × 94 × 55.6	122 × 122 × 55.6	mm
Weight	160	360	1170	1610	g
Detector	MPPC				-
Scintillator	CsI(Tl)				-
Scintillator size (W × D × H)	13 × 13 × 20	38 × 38 × 25	80 × 80 × 25	φ110 × 25	mm
Sampling time	1 to 60 s, adjustable				-
Interface	RS-232C (EIA-232-E)				-
Bit rate	115200				bps
Power supply	+5 V (200 mA typ., 500 mA max.)				-

*1: Excluding the cable and connector

▣ Absolute maximum ratings

Parameter	C12137/-00D	C12137-01/-01D	C12137-08/-08D	C12137-10/-10D	Unit
Operating temperature	-10 to +50	0 to +40			°C
Storage temperature	-20 to +50	-10 to +50			°C

Note: Exceeding the absolute maximum ratings even momentarily may cause a drop in product quality. Always be sure to use the product within the absolute maximum ratings.

▣ Electrical and optical characteristics (Typ. unless otherwise noted)

Parameter	Condition	C12137/-00D	C12137-01/-01D	C12137-08/-08D	C12137-10/-10D	Unit
Counting efficiency min.	¹³⁷ Cs, 0.01 μSv/h	40	400	2000		cpm
Energy range		0.03 to 2		0.06 to 2		MeV
Energy resolution	¹³⁷ Cs, 662 keV	8	8.5	9	10	%
Measurement range (dose rate)	¹³⁷ Cs, 662 keV*2 The lower limit depends on the environmental radiation.	0.01 to 100	0.001 to 10	*3		μSv/h
Measurement error	Excludes attenuation (caused by the shield) and counting fluctuations	±20		*3		%

*2: Measurement range of these products is defined by ¹³⁷Cs. When detecting environmental radiation that mainly consists of low energy radiation, the maximum measurement value will be approx. 1/3 to 1/2 of this figure.

*3: C12137-08/-08D/-10/-10D do not perform conversion into dose rate using the G(E) function.

▣ Block diagram (C12137)

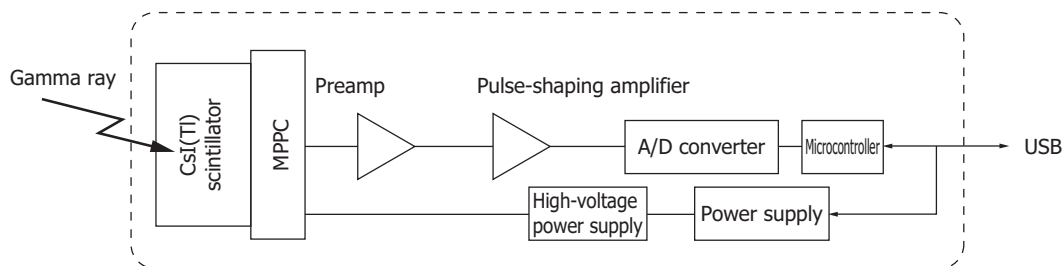

KACCC0632EB

Radiation detection modules incorporating a compact and high-gain MPPC offer the following features:

Feature 01 Detection of low energy gamma rays (down to 30 keV)*4 and energy discrimination

The C12137 series can acquire energy spectra and therefore can perform energy discrimination. ^{137}Cs is known to decay while emitting gamma rays at energies around 662 keV and 32 keV. The C12137/-01 can determine whether gamma rays is from ^{137}Cs by acquiring the energy spectrum from the low-energy gamma rays at around 30 keV. As the gamma rays become lower in energy, the level of light emitted by the scintillator weakens. However, the Radiation detection module, which uses a high sensitivity MPPC, is able to detect gamma rays over a wide range from low-energy gamma rays around 30 keV up to about 2 MeV.*5

The low-light-level detection performance of high gain MPPCs also contributes greatly to reducing the measurement time. To reduce the measurement time, the scintillator capacity must be increased to improve the detection efficiency. However, as the scintillator capacity is increased, the level of light that reaches the photosensor is attenuated inside the scintillator, and the lower limit of detection degrades accordingly. This makes it more difficult to detect low energy gamma rays. The MPPC offers higher gain than the PIN photodiode or APD and makes low-light-level detection possible. Even when it is combined with a large capacity scintillator, low-energy gamma rays can still be measured.

*4: The lower limit of the energy range of the C12137-08/-10 is 60 keV.

*5: C12137/-01

Feature 02 Easy integration in devices

Since the radiation detection module includes a scintillator, photosensor (MPPC), signal processing circuit, interface circuit, and the like in a small case, it can easily be incorporated into portable measuring instruments and in-line measuring instruments.

In the C12137 series, the photosensor MPPC is a small, thin type. The MPPC takes up a small portion of the entire space: the space is predominantly is taken up by the scintillator. This shows that even though the radiation detection module is small, it can provide high photon detection efficiency. Because the radiation detection module is compact, it is advantageous in applications where the radiation dose from the object under measurement is minute. Such applications include inspection of food and beverages. In these types of applications, the periphery of the detector must be covered with lead to eliminate the effects of environmental radiation. Because the radiation detection module is compact, the amount of used lead can be reduced, which in turn reduces the volume and weight of the entire device.

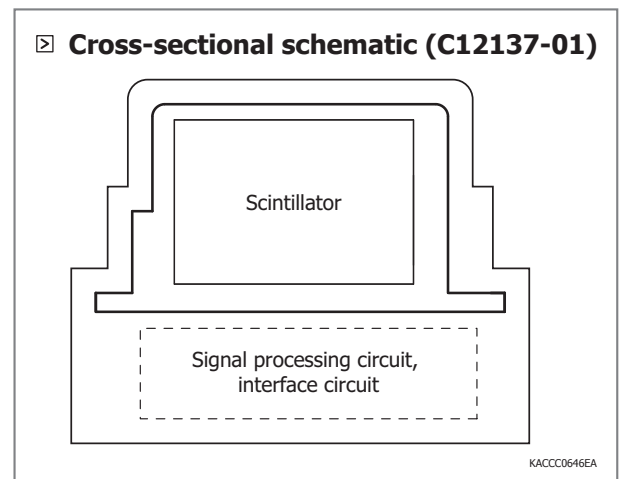

Feature 03 Superb temperature stability

The level of emitted light by the scintillator due to incident gamma rays and the photosensor sensitivity are temperature dependent. This temperature dependence causes a shift in the detected energy when the ambient temperature changes even when gamma rays with the same energy are incident and ultimately causes measurement errors and interferes with radionuclide identification. The gamma ray detector unit of the C12137 series employs a structure with high temperature stability as well as a temperature-compensation circuit, which exhibits excellent temperature stability even when the temperature changes drastically. The graph below illustrates the detected energy shift of the C12137 in response to ambient temperature changes. The temperature stability is $\pm 5\%$ max. in the ambient temperature range of 0 to +50 °C.

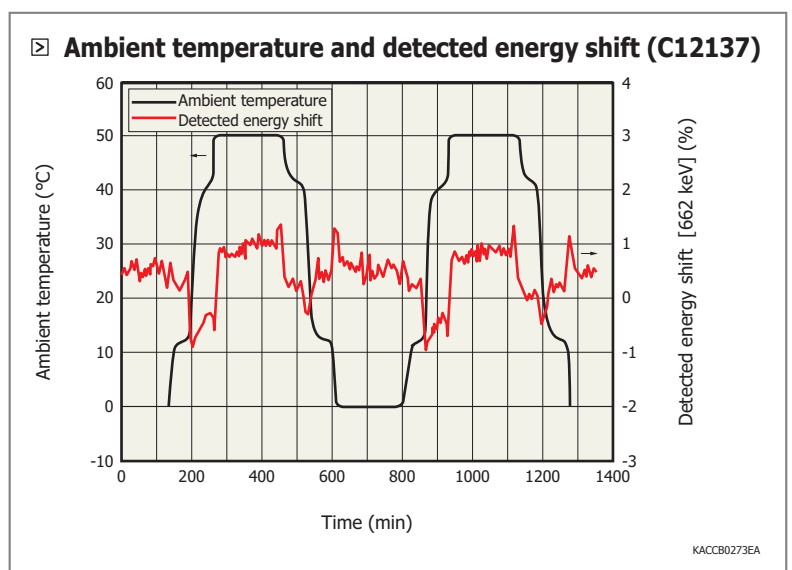

Sample software

The C12137 series comes with sample evaluation software for initial evaluation.

The software provides basic functions for setting measurement conditions, acquiring and saving data, and drawing graphs*5, etc. To help you develop your own application software for operating the radiation detection module integrated in your equipment, function specifications and sample software source code are also provided.

*5: A1 USB type

[Figure 3] Sample software

■ USB type

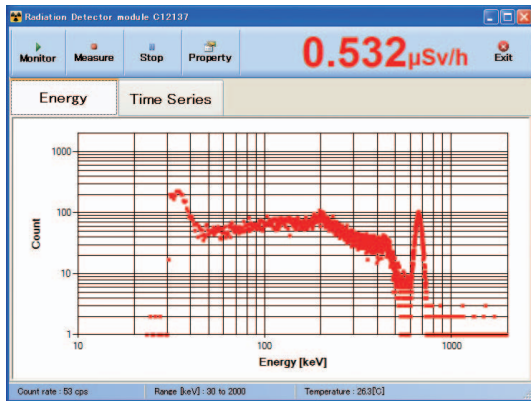

■ RS-232C type

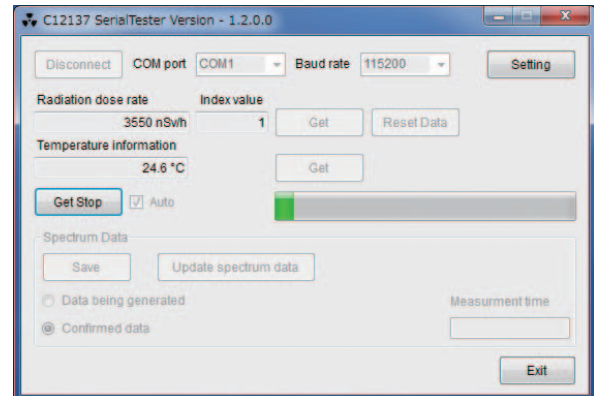

Dimensional outlines (unit: mm)

C12137

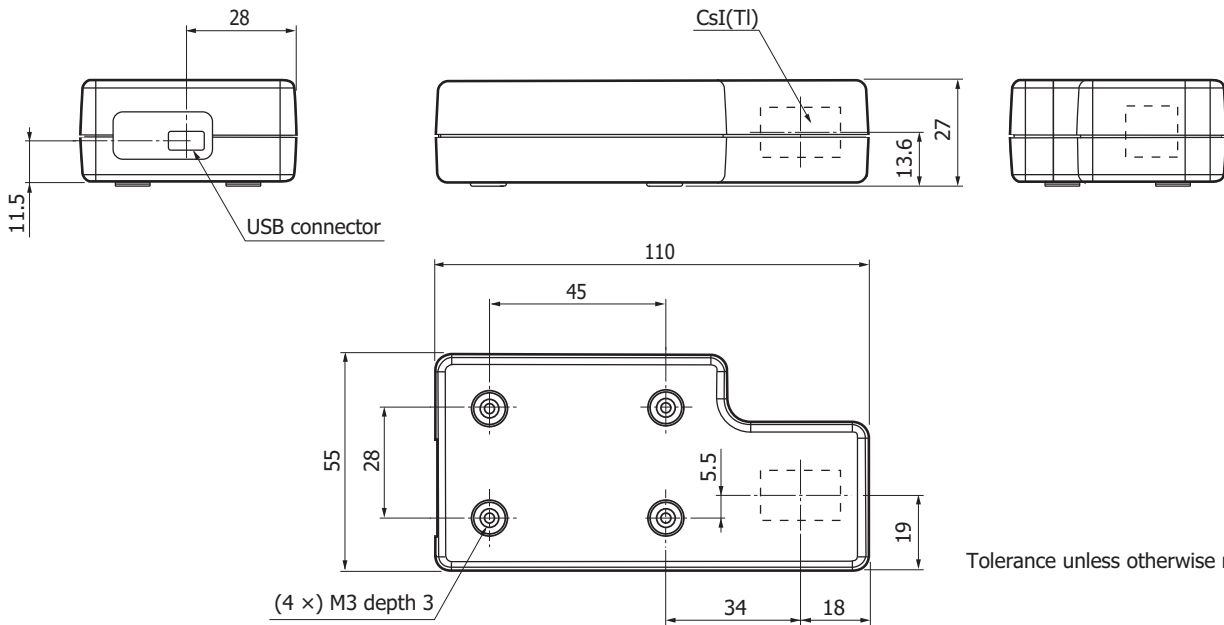

Tolerance unless otherwise noted: ±0.1

KACCA0319EA

C12137-00D

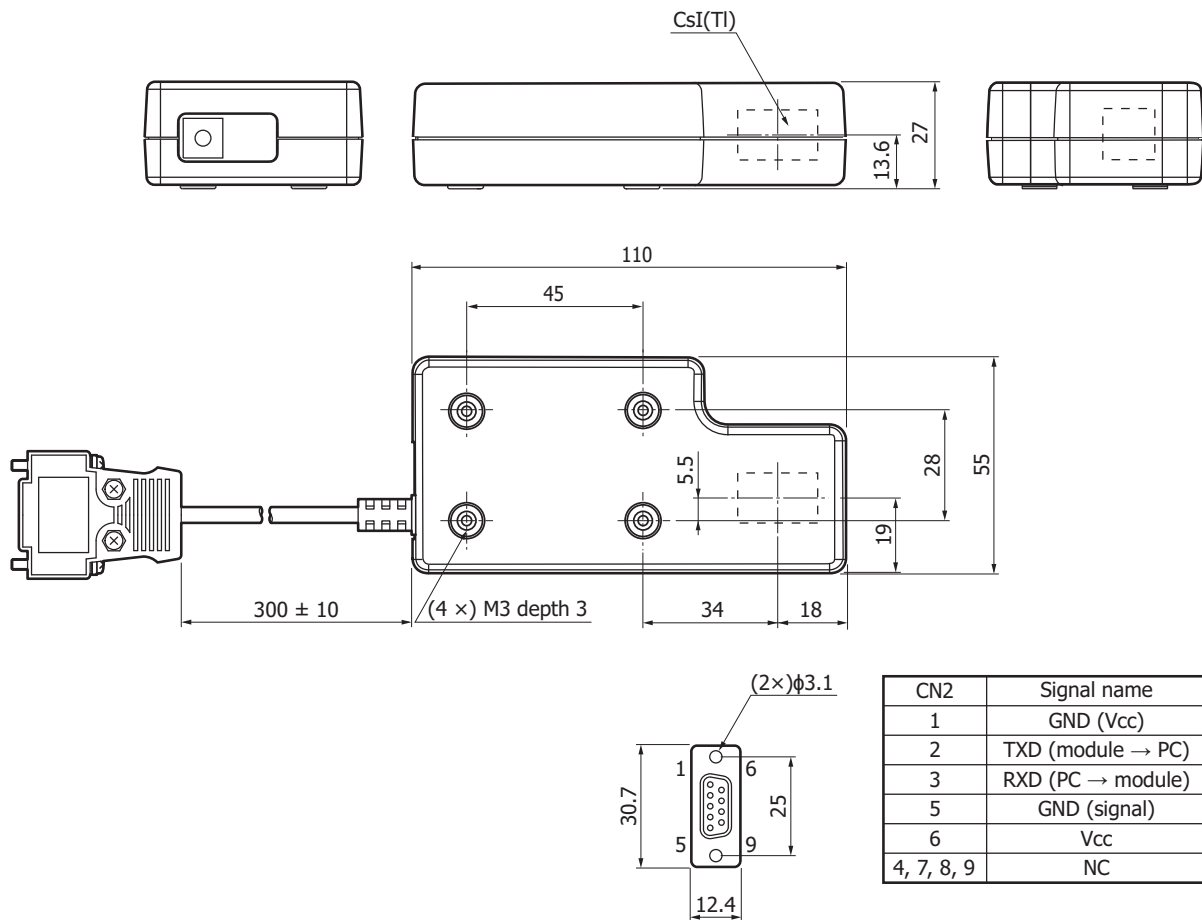

CN2	Signal name
1	GND (Vcc)
2	TXD (module → PC)
3	RXD (PC → module)
5	GND (signal)
6	Vcc
4, 7, 8, 9	NC

Tolerance unless otherwise noted: ±0.1

KACCA0339EA

C12137-01

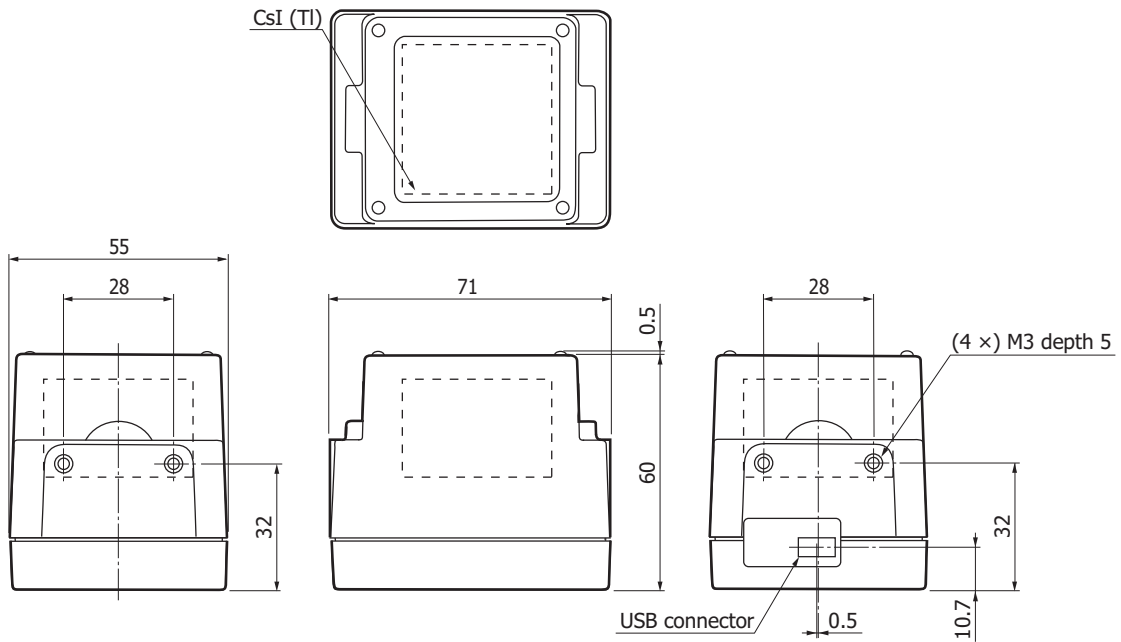

Tolerance unless otherwise noted: ± 0.1

KACCA0320EA

C12137-01D

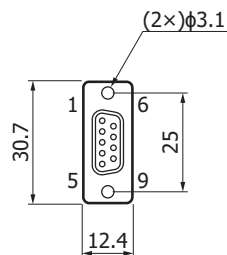
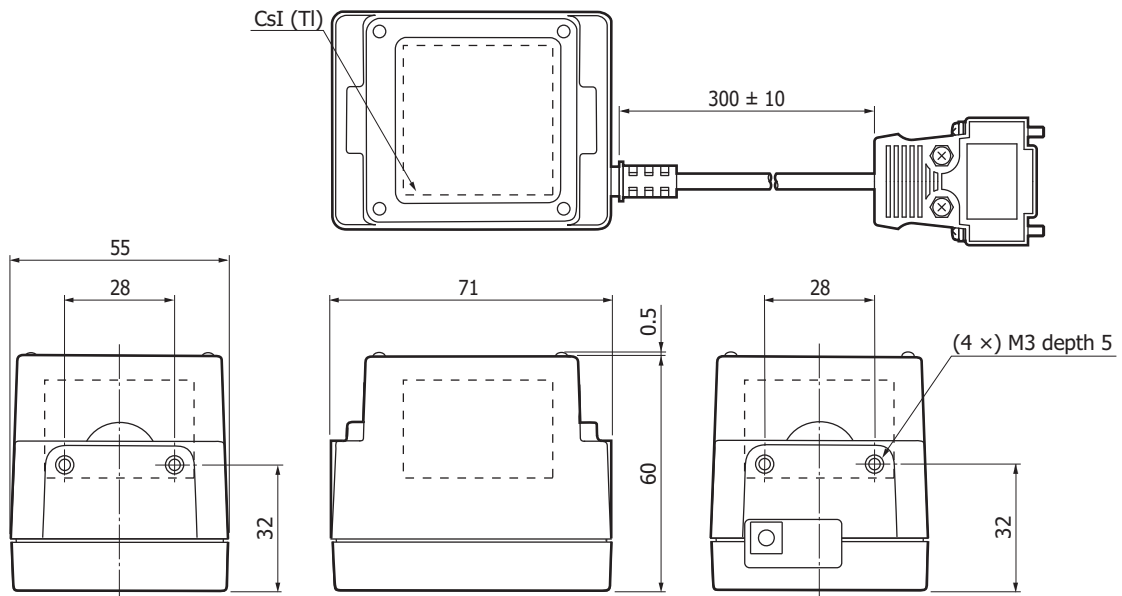

CN2	Signal name
1	GND (Vcc)
2	TXD (module → PC)
3	RXD (PC → module)
5	GND (signal)
6	Vcc
4, 7, 8, 9	NC

Tolerance unless otherwise noted: ± 0.1

KACCA0340EA

C12137-08

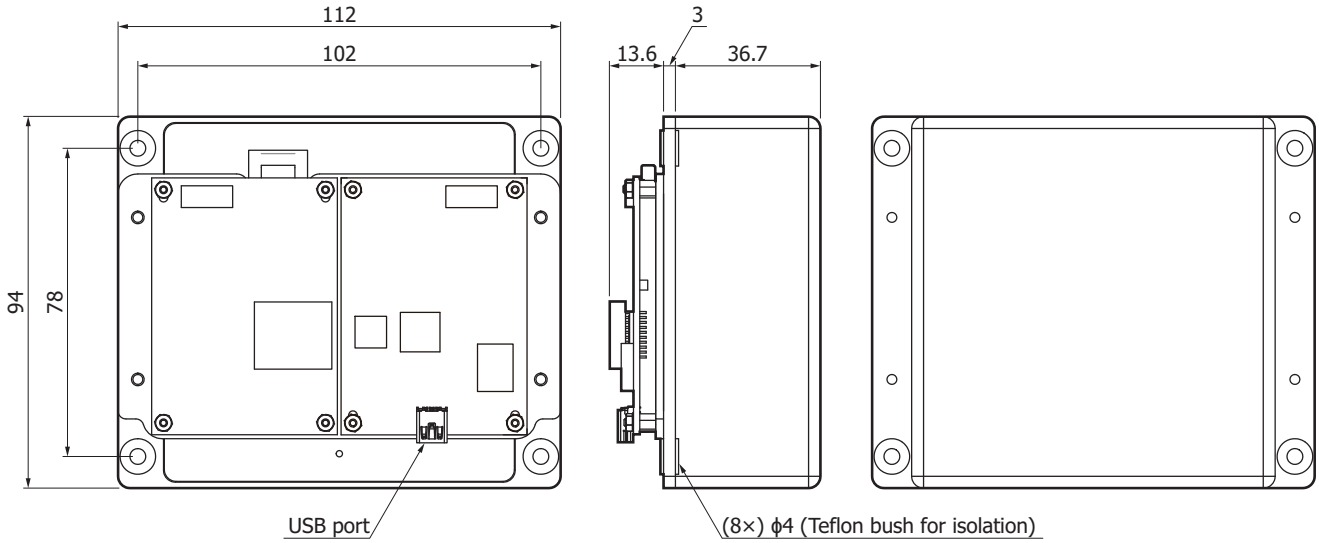

Tolerance unless otherwise noted: ±0.1

KACCA0341EA

C12137-08D

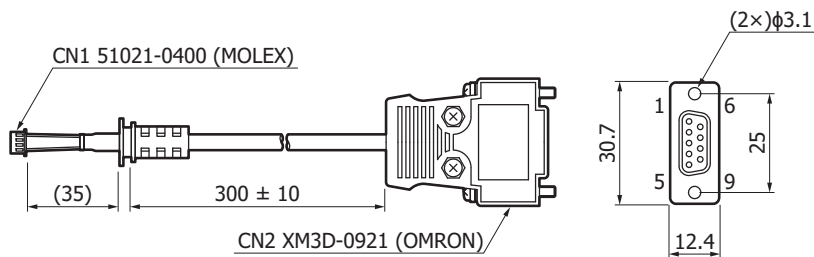
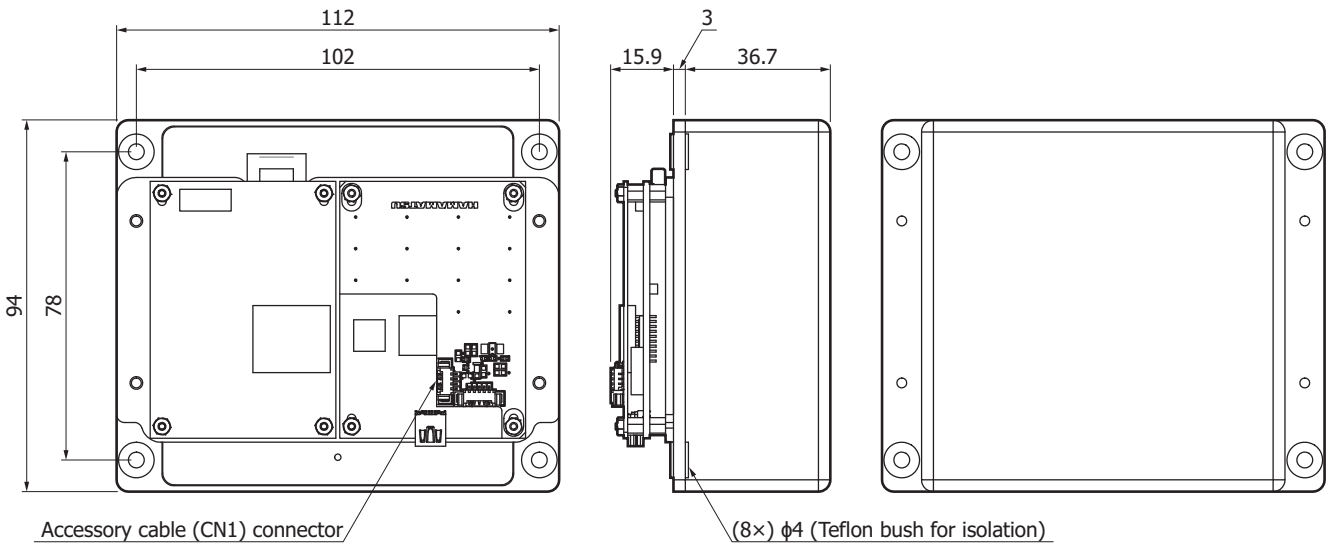

CN2	Signal name
1	GND (Vcc)
2	TXD (module → PC)
3	RXD (PC → module)
5	GND (signal)
6	Vcc
4, 7, 8, 9	NC

Tolerance unless otherwise noted: ±0.1

KACCA0342EA

C12137-10

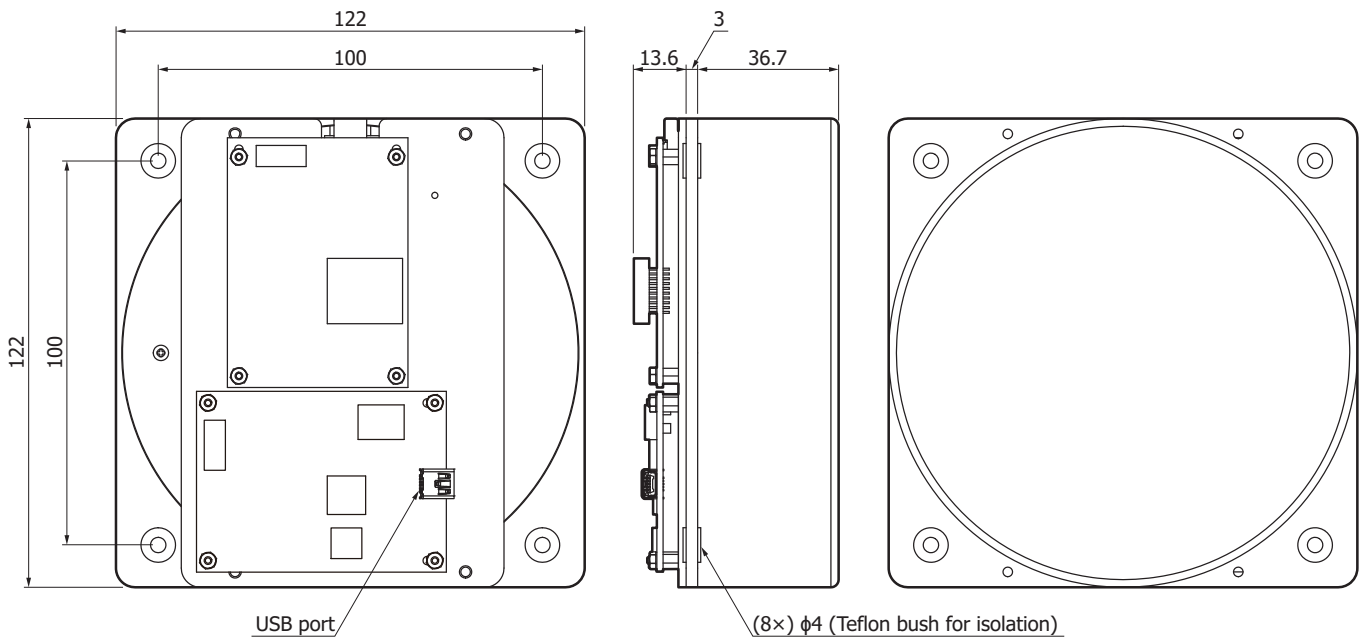

Tolerance unless otherwise noted: ± 0.1

KACCA0343EA

C12137-10D

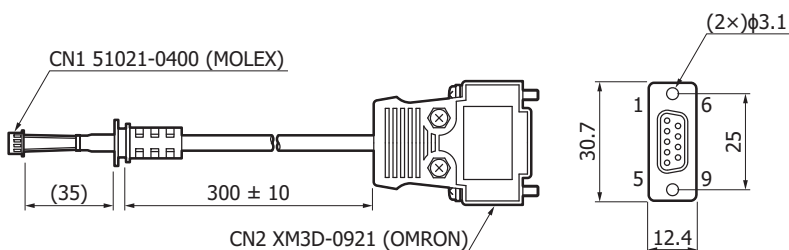
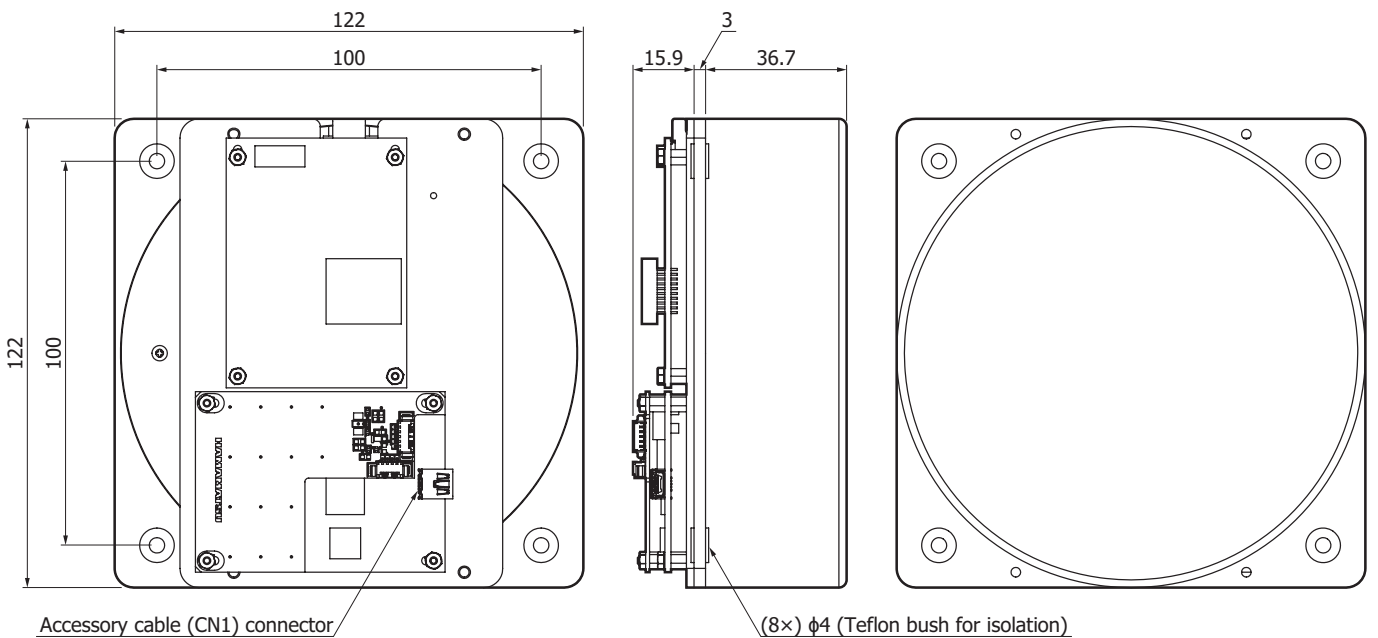

CN2	Signal name
1	GND (Vcc)
2	TXD (module \rightarrow PC)
3	RXD (PC \rightarrow module)
5	GND (signal)
6	Vcc
4, 7, 8, 9	NC

Tolerance unless otherwise noted: ± 0.1

KACCA0344EA

Precautions

- These products are precision devices that use a scintillator and are not designed to be used outdoors or in locations subject to vibration or shock. To use them in such an environment, you will need to incorporate appropriate measures in the design.

Accessories

- USB cable
- CD-ROM (instruction manual, sample software)

Related information

www.hamamatsu.com/sp/ssd/doc_en.html

Precautions

- Disclaimer

MPPC is a registered trademark of Hamamatsu Photonics K.K.

Windows is a registered trademark of Microsoft Corporation in the United States and/or other countries.

Information described in this material is current as of June 2018.

Product specifications are subject to change without prior notice due to improvements or other reasons. This document has been carefully prepared and the information contained is believed to be accurate. In rare cases, however, there may be inaccuracies such as text errors. Before using these products, always contact us for the delivery specification sheet to check the latest specifications.

The product warranty is valid for one year after delivery and is limited to product repair or replacement for defects discovered and reported to us within that one year period. However, even if within the warranty period we accept absolutely no liability for any loss caused by natural disasters or improper product use. Copying or reprinting the contents described in this material in whole or in part is prohibited without our prior permission.

HAMAMATSU

www.hamamatsu.com

HAMAMATSU PHOTONICS K.K., Solid State Division

1126-1 Ichino-cho, Higashi-ku, Hamamatsu City, 435-8558 Japan, Telephone: (81) 53-434-3311, Fax: (81) 53-434-5184

U.S.A.: Hamamatsu Corporation: 360 Foothill Road, Bridgewater, N.J. 08807, U.S.A., Telephone: (1) 908-231-0960, Fax: (1) 908-231-1218, E-mail: usa@hamamatsu.com

Germany: Hamamatsu Photonics Deutschland GmbH: Arzbergerstr. 10, D-82211 Herrsching am Ammersee, Germany, Telephone: (49) 8152-375-0, Fax: (49) 8152-265-8, E-mail: info@hamamatsu.de

France: Hamamatsu Photonics France S.A.R.L.: 19, Rue du Saule Trapu, Parc du Moulin de Massy, 91882 Massy Cedex, France, Telephone: 33-(1) 69 53 71 00, Fax: 33-(1) 69 53 71 10, E-mail: infos@hamamatsu.fr

United Kingdom: Hamamatsu Photonics UK Limited: 2 Howard Court, 10 Tewin Road, Welwyn Garden City, Hertfordshire AL7 1BW, United Kingdom, Telephone: (44) 1707-294888, Fax: (44) 1707-325777, E-mail: info@hamamatsu.co.uk

North Europe: Hamamatsu Photonics Norden AB: Torshamnsgatan 35 16440 Kista, Sweden, Telephone: (46)8-509 031 00, Fax: (46)8-509 031 01, E-mail: info@hamamatsu.se

Italy: Hamamatsu Photonics Italia S.r.l.: Strada della Moia, 1 int. 6, 20020 Arese (Milano), Italy, Telephone: (39)02-93 58 17 33, Fax: (39)02-93 58 17 41, E-mail: info@hamamatsu.it

China: Hamamatsu Photonics (China) Co., Ltd.: B1201, Jiaming Center, No.27 Dongsanhuan Beilu, Chaoyang District, Beijing 100020, China, Telephone: (86) 10-6586-6006, Fax: (86) 10-6586-2866, E-mail: hpc@hamamatsu.com.cn

Taiwan: Hamamatsu Photonics Taiwan Co., Ltd.: 8F-3, No. 158, Section2, Gongdao 5th Road, East District, Hsinchu, 300, Taiwan R.O.C. Telephone: (886)03-659-0080, Fax: (886)03-659-0081, E-mail: info@hamamatsu.com.tw