

■Features

- Lateral multimode (broad stripe)
- Radiant output power (CW): 1 W
- Peak emission wavelength: 980 nm
- Emitting area size: 100 μm × 1 μm

■Applications

- Pumping source for solid state laser
- Medical instrument
- Measure instrument
- Communication (EDFA)



■Absolute maximum ratings (T_{op(C)} = 25 °C)

Parameter	Symbol	Value	Unit
Radiant output power	Φ _e	1.2	W
Forward current	I _f	1.4	A
Reverse voltage	V _r	2	V
Operating temperature	T _{op(C)}	0 to +30	°C
Storage temperature	T _{stg}	-30 to +80	°C

■Electrical and optical characteristics (T_{op(C)} = 25 °C)

Parameter	Symbol	Conditions	Value			Unit	
			Min.	Typ.	Max.		
Radiant output power	Φ _e	Φ _e = 1 W	0.8	1	—	W	
Operating voltage	I _{op}		—	1.2	1.38	A	
Peak emission wavelength	λ _p		970	980	990	nm	
Spectral half-width	Δλ		—	2	4	nm	
Operating voltage	V _f		—	2	3	V	
Beam spread angle	Horizontal		θ _{//}	5	8	12	degree
	Vertical		θ _⊥	27	32	37	degree
Emitting area	—		—	100 × 1	—	μm	
Lasing threshold current	I _{th}		—	—	0.25	0.35	A

CW Laser Diode L9418-42

Figure 1: Radiant output power vs. Operating current (typ.)

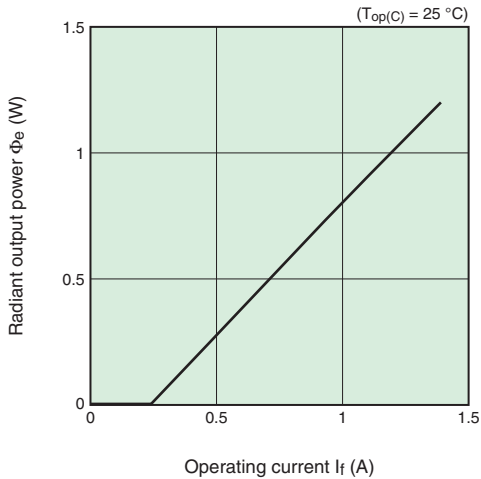

Figure 2: Typical emission spectrum

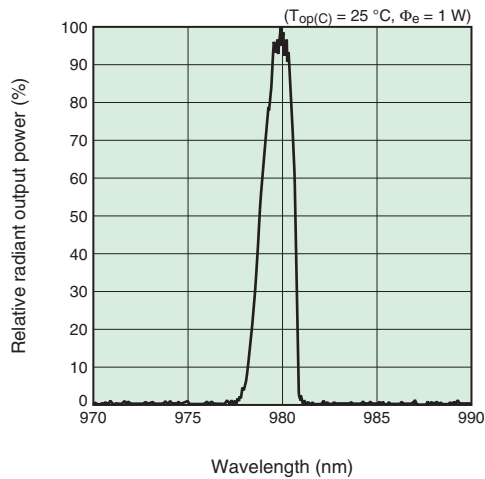

Figure 3: Directivity (typ.)

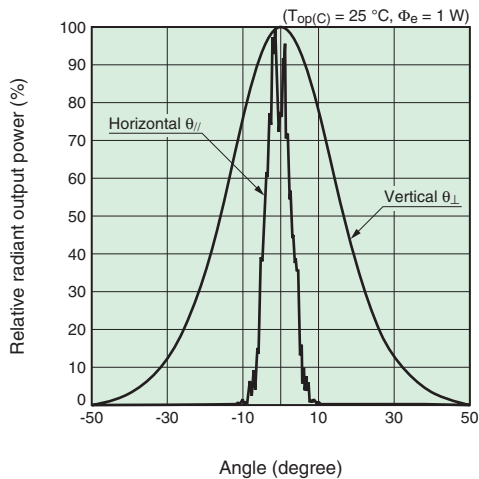
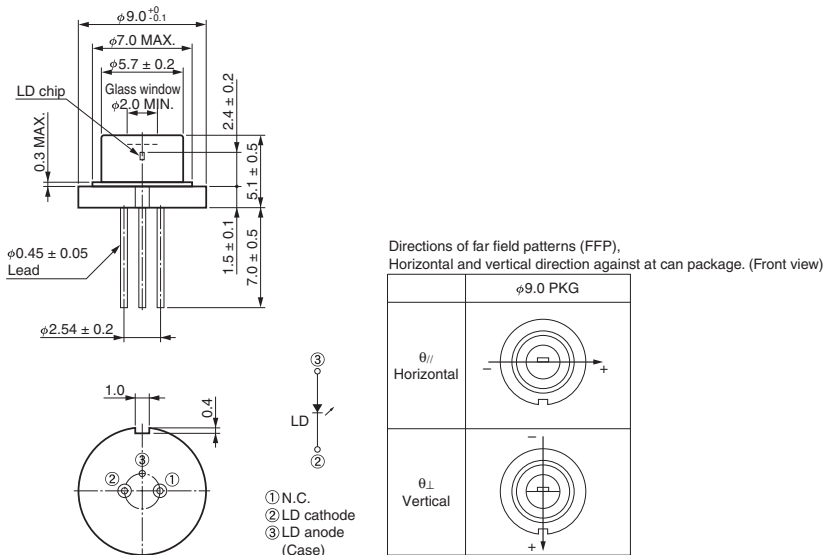

Figure 4: Dimensional outline (unit: mm)



HAMAMATSU PHOTONICS K.K. www.hamamatsu.com

HAMAMATSU PHOTONICS K.K., Laser Promotion Division, Business Promotion G.
1-8-3, Shinmiyakoda, Kita-ku, Hamamatsu City, Shizuoka, 431-2103, Japan, Telephone: (81)53-484-1301, Fax: (81)53-484-1302, E-mail: sales-laser@lpd.hpk.co.jp
U.S.A.: Hamamatsu Corporation: 360 Foothill Road, Bridgewater, NJ 08807, U.S.A., Telephone: (1)908-231-0960, Fax: (1)908-231-1218 E-mail: usa@hamamatsu.com
Germany: Hamamatsu Photonics Deutschland GmbH: Arzbergerstr. 10, D-82211 Herrsching am Ammersee, Germany, Telephone: (49)8152-375-0, Fax: (49)8152-265-8 E-mail: info@hamamatsu.de
France: Hamamatsu Photonics France S.A.R.L.: 19, Rue du Saule Trapu, Parc du Moulin de Massy, 91882 Massy Cedex, France, Telephone: (33)1 69 53 71 00, Fax: (33)1 69 53 71 10 E-mail: infos@hamamatsu.fr
United Kingdom: Hamamatsu Photonics UK Limited: 2 Howard Court, 10 Tewin Road, Welwyn Garden City, Hertfordshire AL7 1BW, UK, Telephone: (44)1707-294888, Fax: (44)1707-325777 E-mail: info@hamamatsu.co.uk
North Europe: Hamamatsu Photonics Norden AB: Torshamnsgatan 35 16440 Kista, Sweden, Telephone: (46)8-509 031 00, Fax: (46)8-509 031 01 E-mail: info@hamamatsu.se
Italy: Hamamatsu Photonics Italia S.r.l.: Strada della Moia, 1 int. 6, 20020 Arese (Milano), Italy, Telephone: (39)02-93 58 17 33, Fax: (39)02-93 58 17 41 E-mail: info@hamamatsu.it
China: Hamamatsu Photonics (China) Co., Ltd.: 1201 Tower B, Jiaming Center, 27 Dongsanhuan Beilu, Chaoyang District, 100020 Beijing, China, Telephone: (86)10-6586-6006, Fax: (86)10-6586-2866 E-mail: hpc@hamamatsu.com.cn
Taiwan: Hamamatsu Photonics Taiwan Co., Ltd.: 8F-3, No.158, Section2, Gongdao 5th Road, East District, Hsinchu, 300, Taiwan R.O.C. Telephone: (886)03-659-0080, Fax: (886)03-659-0081 E-mail: info@hamamatsu.com.tw

Cat. No. LCWLD2017E01
MAR. 2018 IP