



L11767 series

High output power red emitting diode

The L11767 series are high output red LEDs that deliver light output more than twice that of our previous products. Electric power required to provide the same brightness as the previous products is reduced by as much as 70%. The L11767 series also offer high reliability since they are 4-element (AlGaInP) LEDs.

Features

- High radiant output power (more than twice compared to previous products)
L11767: 13 mW typ. (I_F=20 mA)
L11767-0066L: 7.0 mW typ. (I_F=20 mA)
- High reliability

Applications

- Optical switches, etc.

Structure

Parameter	Symbol	Condition	L11767	L11767-0066L	Unit
Package	-		TO-46		-
Reflector	-		No	Yes	-
Window material	-		Resin	Borosilicate glass	-
AR coating	-		No		-
Lens	-		No	Spherical	-

Absolute maximum ratings (T_a=25 °C unless otherwise noted)

Parameter	Symbol	Condition	L11767	L11767-0066L	Unit
Reverse voltage	V _R		5		V
Forward current	I _F		60		mA
Derating rate of forward current	-	T _a > 25 °C	0.8		mA/°C
Pulse forward current	I _{FP}	Pulse width=10 μs Duty ratio=1%	0.5		A
Derating rate of pulse forward current	-	T _a > 25 °C	6.7		mA/°C
Power dissipation	P		180		mW
Operating temperature	T _{opr}		-30 to +85		°C
Storage temperature	T _{stg}	*1	-40 to +100		°C
Soldering condition	-		Less than 260 °C, within 5 seconds *2		-

*1: Guaranteed to resist temperature cycle test of up to 5 cycles (L11767 only)

*2: At a position at least 1 mm away from the lead base

Note: Exceeding the absolute maximum ratings even momentarily may cause a drop in product quality. Always be sure to use the product within the absolute maximum ratings.

Electrical and optical characteristics (Ta=25 °C)

Parameter	Symbol	Condition	L11767			L11767-0066L			Unit
			Min.	Typ.	Max.	Min.	Typ.	Max.	
Peak emission wavelength	λ_p	IF=20 mA	650	660	670	650	660	670	nm
Spectral half-width	$\Delta\lambda$	IF=20 mA	-	18	30	-	18	30	nm
Forward voltage	VF	IF=20 mA	-	2.1	2.5	-	2.1	2.5	V
Reverse current	IR	VR=5 V	-	-	20	-	-	20	μ A
Radiant flux	ϕ_e	IF=20 mA	10	13	-	5	7	-	mW
Cutoff frequency*3	fc	IF=20 mA \pm 1 mAp-p	3	6	-	3	6	-	MHz

*3: Frequency at which the light output drops by 3 dB relative to the output at 100 kHz

Emission spectrum

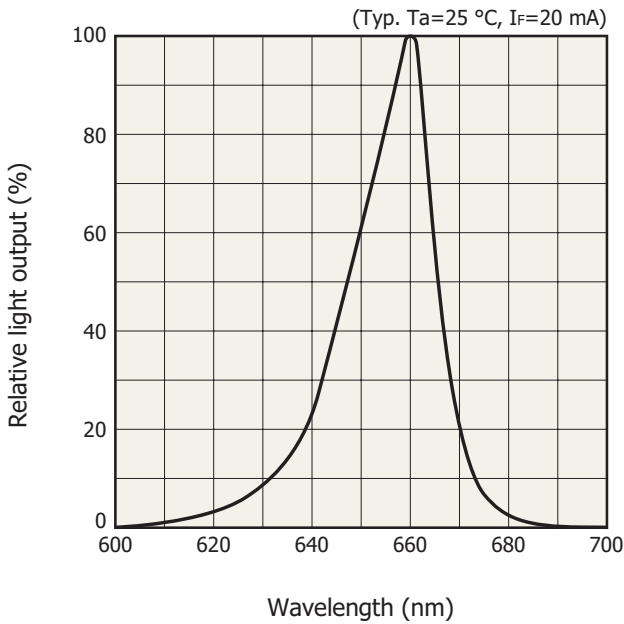

KLEDB0344EA

Radiant flux vs. pulse forward current

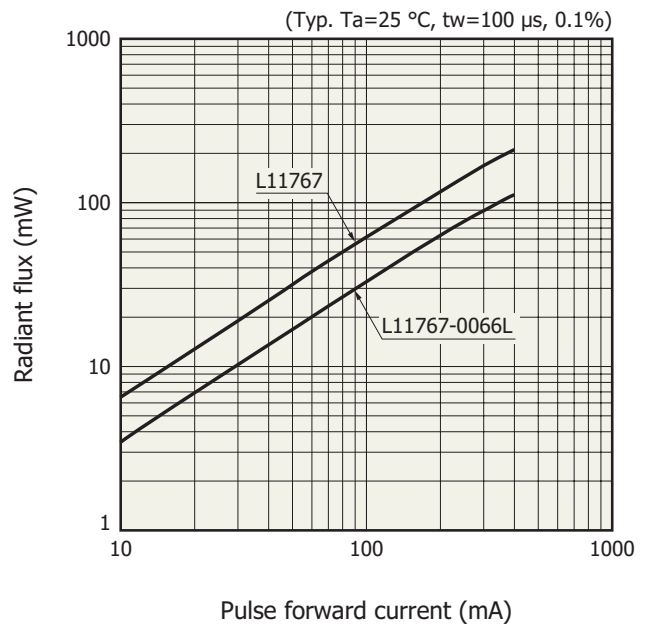

KLEDB0345ED

Pulse forward current vs. pulse forward voltage

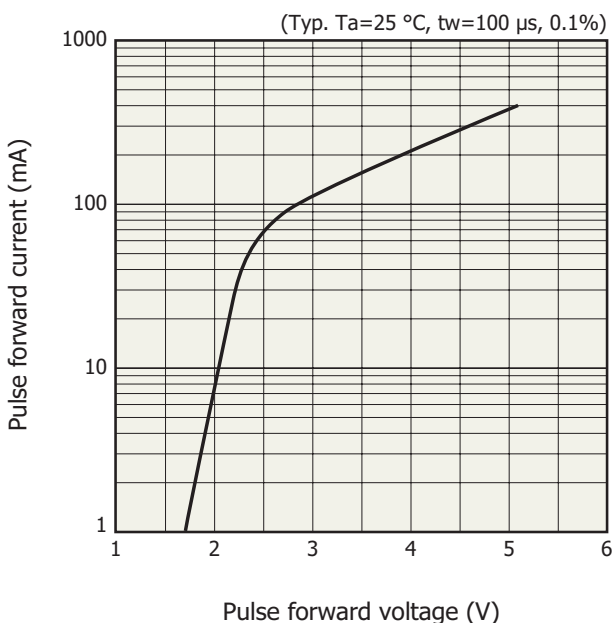

KLEDB0346EB

Directivity

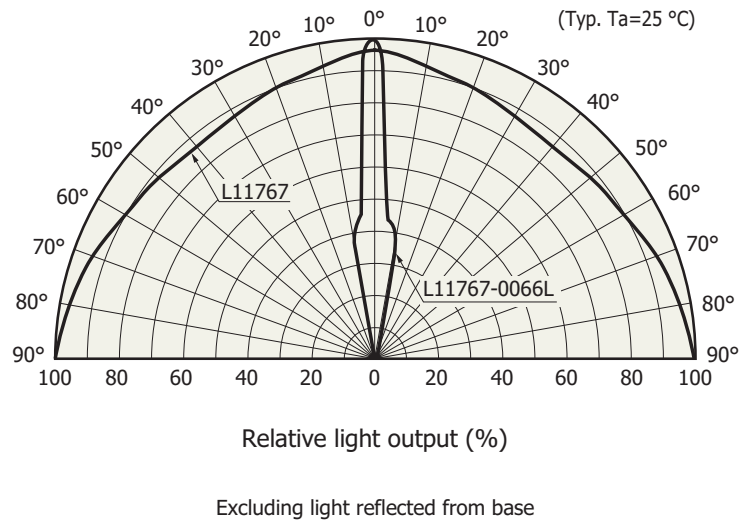

KLEDB0348EB

Light output vs. ambient temperature

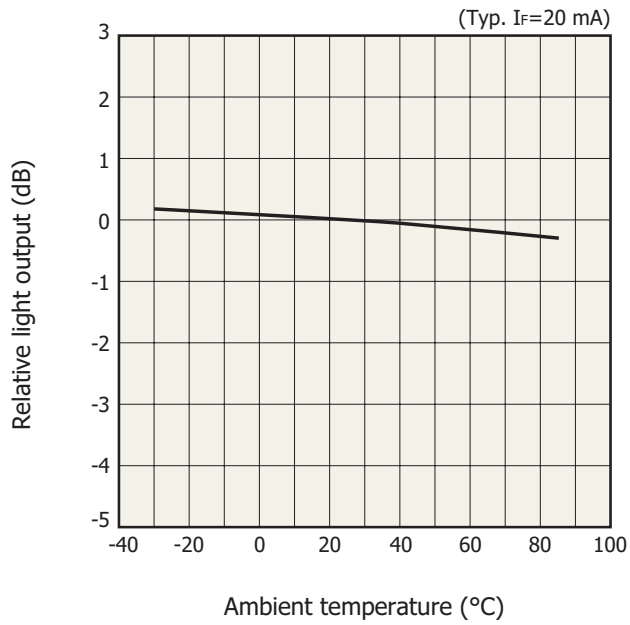

KLEDB0347EA

Allowable forward current vs. ambient temperature

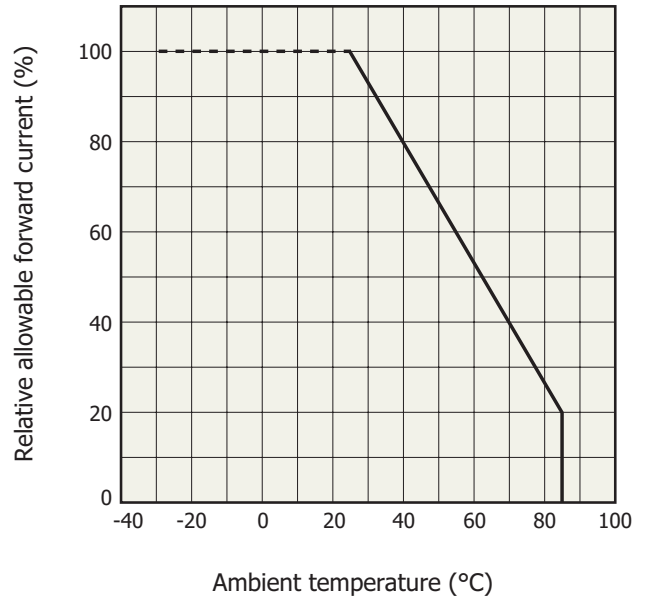

KLEDB0027EC

Allowable forward current vs. duty ratio

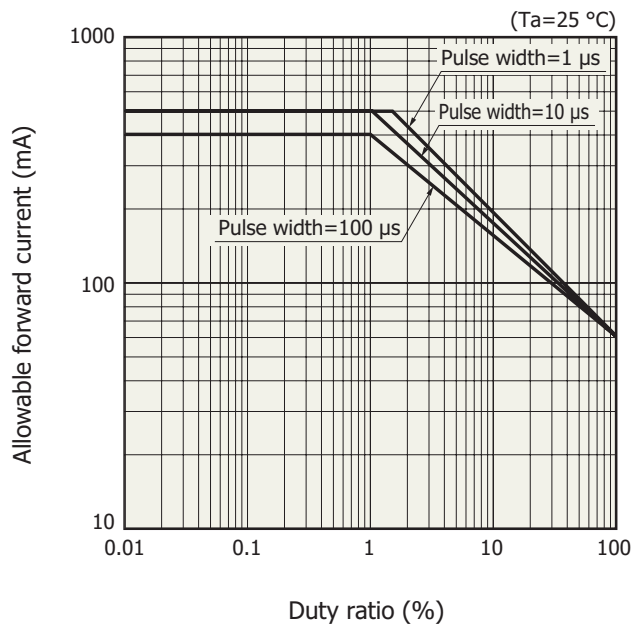

KLEDB0349EB

Dimensional outlines (unit: mm)

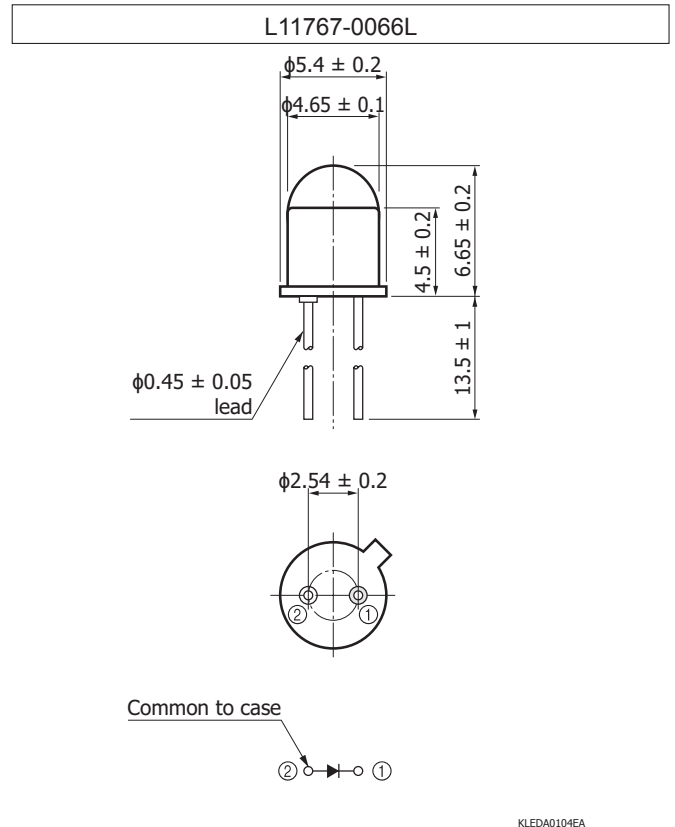
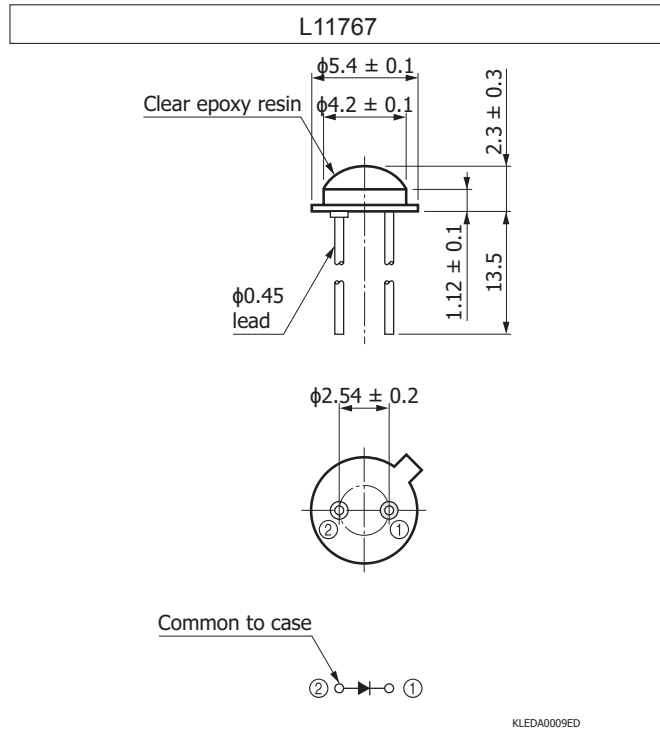

Related information

www.hamamatsu.com/sp/ssd/doc_en.html

Precautions

- Disclaimer
- Metal, ceramic, plastic products

Information described in this material is current as of December 2017.

Product specifications are subject to change without prior notice due to improvements or other reasons. This document has been carefully prepared and the information contained is believed to be accurate. In rare cases, however, there may be inaccuracies such as text errors. Before using these products, always contact us for the delivery specification sheet to check the latest specifications.

The product warranty is valid for one year after delivery and is limited to product repair or replacement for defects discovered and reported to us within that one year period. However, even if within the warranty period we accept absolutely no liability for any loss caused by natural disasters or improper product use. Copying or reprinting the contents described in this material in whole or in part is prohibited without our prior permission.

HAMAMATSU

www.hamamatsu.com

HAMAMATSU PHOTONICS K.K., Solid State Division

1126-1 Ichino-cho, Higashi-ku, Hamamatsu City, 435-8558 Japan, Telephone: (81) 53-434-3311, Fax: (81) 53-434-5184

U.S.A.: Hamamatsu Corporation: 360 Foothill Road, Bridgewater, N.J. 08807, U.S.A., Telephone: (1) 908-231-0960, Fax: (1) 908-231-1218, E-mail: usa@hamamatsu.com

Germany: Hamamatsu Photonics Deutschland GmbH: Arzbergerstr. 10, D-82211 Herrsching am Ammersee, Germany, Telephone: (49) 8152-375-0, Fax: (49) 8152-265-8, E-mail: info@hamamatsu.de

France: Hamamatsu Photonics France S.A.R.L.: 19, Rue du Saule Trapu, Parc du Moulin de Massy, 91882 Massy Cedex, France, Telephone: 33-(1) 69 53 71 00, Fax: 33-(1) 69 53 71 10, E-mail: infos@hamamatsu.fr

United Kingdom: Hamamatsu Photonics UK Limited: 2 Howard Court, 10 Tewin Road, Welwyn Garden City, Hertfordshire AL7 1BW, United Kingdom, Telephone: (44) 1707-294888, Fax: (44) 1707-325777, E-mail: info@hamamatsu.co.uk

North Europe: Hamamatsu Photonics Norden AB: Torshamnsgatan 35 16440 Kista, Sweden, Telephone: (46)8-509 031 00, Fax: (46)8-509 031 01, E-mail: info@hamamatsu.se

Italy: Hamamatsu Photonics Italia S.r.l.: Strada della Moia, 1 int. 6, 20020 Arese (Milano), Italy, Telephone: (39)02-93 58 17 33, Fax: (39)02-93 58 17 41, E-mail: info@hamamatsu.it

China: Hamamatsu Photonics (China) Co., Ltd.: B1201, Jiaming Center, No.27 Dongsanhuan Beilu, Chaoyang District, Beijing 100020, China, Telephone: (86) 10-6586-6006, Fax: (86) 10-6586-2866, E-mail: hpc@hamamatsu.com.cn

Taiwan: Hamamatsu Photonics Taiwan Co., Ltd.: 8F-3, No. 158, Section2, Gongdao 5th Road, East District, Hsinchu, 300, Taiwan R.O.C. Telephone: (886)03-659-0080, Fax: (886)03-659-0081, E-mail: info@hamamatsu.com.tw