



C7180

C7181

## Detector heads for back-thinned CCD area image sensor

The C7180 and C7181 are high-sensitivity multichannel detector heads designed for 512 × 512 pixel, back-thinned FFT-CCD area image sensors (S7170-0909, S7171-0909-01). The C7180 works with non-cooled type back-thinned CCD area image sensor (S7170-0909-01) and the C7181 with one-stage thermoelectrically cooled type (S7171-0909-01). Both the C7180 and C7181 have a low noise driver/amplifier circuit that operates the CCD image sensor by input of simple external signals. The C7181 also includes a highly stable temperature controller that cools the sensor to a preset temperature level (T<sub>chip</sub>=-10 °C) as soon as the power is turned on. If the cooler fails and causes internal circuitry to overheat, the built-in protection circuit automatically turns off the power. Despite its compact size, the housing configuration is designed for good heat dissipation, and threaded mounting holes on the front panel allow connections to other devices such as monochrometers. Controller for multichannel detector head the C7557-01 is also available. The software supplied with the C7557-01 allows easy control of the multichannel detector head and data acquisition.

### Features

- **Designed for back-thinned CCD area image sensor\*1**  
C7180: for non-cooled type (S7170-0909)  
C7181: for TE-cooled type (S7171-0909-01)
- **Choice of line binning operation\*2/area scanning operation**
- **Built-in driver circuit**
- **Highly stable temperature controller (C7181)**
- **Operates with simple input signals**
- **High UV sensitivity and high quantum efficiency**
- **Compact configuration**

### Applications

- **Scientific measurement instrument**
- **Semiconductor inspection**
- **UV imaging**
- **Biophoton observation**

### Selection guide

The table below shows CCD area image sensors applicable for the C7180, C7181. Since the C7180, C7181 do not include a CCD area image sensor, so select the desired sensor and order it separately.

Type no.	CCD area image sensor				
	Type no.	Cooling	Number of total pixels	Number of effective pixels	Image area [mm (H) × mm (V)]
C7180	S7170-0909	Non-cooled	532 × 520	512 × 512	12.288 × 12.288
C7181	S7171-0909-01	One-stage TE-cooled			

\*1: In normal CCD image sensors that receive light from the front surface, the photosensitive area is covered with transparent electrodes for charge transfer. These electrodes cut off UV radiation incident on the image sensor and also reduce the quantum efficiency. In contrast, back-thinned CCD image sensors have a unique structure in which the back of the active area is finely ground to allow light to enter from the back surface. This structure ensures high UV sensitivity and quantum efficiency because incident light need not pass through the transparent electrodes.

\*2: The FFT-CCD was originally designed as a two-dimensional image sensor. However, it can be operated like a linear image sensor having a large active area by transferring all the pixel signals in the vertical direction to the horizontal register (this is referred to as line binning).

**▣ Absolute maximum ratings**

Parameter	Symbol	Min.	Typ.	Max.	Unit	
Supply voltage (for digital circuitry)	VD1, VD2	-0.5	-	+7	V	
Supply voltage (for analog circuitry)	VA1+	-	-	+18		
	VA1-	-	-	-18		
	VA2	-	-	+30		
Supply voltage*3	Vp	-	-	+7		
	VF	-	-	+14		
Digital input voltage	-	-	-	VD1, VD2		
Operating temperature	C7180	Topr	0	-	+50	°C
	C7181		+10	-	+35*4	
Storage temperature	C7180	Tstg	-20	-	+70	
	C7181		0	-	+50	

\*3: C7181

\*4: The maximum value may be lower, depending on the drive frequency and the number of sensor pixels.

Note: Exceeding the absolute maximum ratings even momentarily may cause a drop in product quality. Always be sure to use the product within the absolute maximum ratings.

**▣ Electrical characteristics**

(Unless otherwise noted, Ta=25 °C,

**C7180: VD1=+5 V, VA1+=+15 V, VA1-=-15 V, VA2=+24 V,**

**C7181: VD1, VD2=+5 V, VA1+=+15 V, VA1-=-15 V, VA2=+24 V, Vp=+5 V, VF=+12 V)**

Parameter	Symbol	Min.	Typ.	Max.	Unit	
Digital input	High level	VIH	+2.0	-	VD1, VD2	V
	Low level	VIL	-0.5	-	+0.8	V
Clock pulse frequency	fCLK	-	-	1	MHz	
Data video readout frequency	fV	-	-	fCLK/4	Hz	
Start pulse width	tst	1/fCLK	-	-	s	
Digital output	High level (Io=-6 mA)	VIH	+2.0	-	-	V
	Low level (Io=+6 mA)	VIL	-	-	+0.8	V
Power supply operating conditions						
Voltage	Digital circuitry	VD1	+4.75	+5.0	+5.25	V
	Analog circuitry	VA1+	+14.5	+15.0	+15.5	V
		VA1-	-14.5	-15.0	-15.5	V
		VA2	+23.5	+24.0	+24.5	V
	Other*5	VD2	+4.75	+5.0	+5.25	V
		Vp	+4.75	+5.0	+5.25	V
VF		+11.75	+12.0	+12.25	V	
Current	VD1 (+5 V)	-	-	-	+200	mA
	VA1+ (+15 V)	-	-	-	+100	mA
	VA1- (-15 V)	-	-	-	-100	mA
	VA2 (+24 V)	-	-	-	+30	mA
	VD2 (+5 V)*5	-	-	-	+30	mA
	Vp (+5 V)*5	-	-	-	+2.5	A
	VF (+12 V)*5	-	-	+100	-	mA

\*5: C7181

**Electrical and optical characteristics**

(Unless otherwise noted,

**C7180: Ta=25 °C, Vd1=+5 V, VA1+=+15 V, VA1-=-15 V, VA2=+24 V**

**C7181: Tchip=-10 °C, Vd1, Vd2=+5 V, VA1+=+15 V, VA1-=-15 V, VA2=+24 V, Vp=+5 V, Vf=+12 V)**

Parameter	Symbol	Min.	Typ.	Max.	Unit
Spectral response range	$\lambda$	-	200 to 1100	-	nm
Full well capacity	Vertical	240	320	-	ke <sup>-</sup>
	Horizontal	300	600	-	
Conversion gain* <sup>6</sup>	Sv	-	15	-	$\mu\text{V}/e^-$
Dark current	C7180	-	100	1000	e <sup>-</sup> /pixel/s
	C7181	-	3	30	
Readout noise	C7180	-	40	-	e <sup>-</sup> rms
	C7181	-	20	-	
Dynamic range	C7180	-	15000	-	-
	C7181	-	30000	-	
Photoresponse nonuniformity* <sup>7</sup>	PRNU	-	-	±10	%

\*6: Including the circuit gain

\*7: Measured at 50% of the full well capacity

**Specifications for temperature controller (C7181)**

(Unless otherwise noted, Ta=25 °C, Vd1, Vd2=+5 V, VA1+=+15 V, VA1-=-15 V, VA2=+24 V, Vd2=+5 V, Vp=+5 V, Vf=+12 V)

Parameter* <sup>8</sup>	Symbol	Min.	Typ.	Max.	Unit
Cooling temperature	Ts	-11.5	-10	-8.5	°C
Temperature control range	$\Delta T_d$	-0.05	-	+0.05	°C
Power dissipation of TE-cooler element	Pp	-	-	7	W
Cool down time to reset temperature	to	-	-	5	min
Setting temperature for overheat protection* <sup>9</sup>	To	-	+45	-	°C

\*8: Other functions include error display, automatic power off, and detection of electrical opens and shorts by the thermosensor.

\*9: Temperature on the rear of the case (where the fan is installed)

**Block diagram (C7181)**

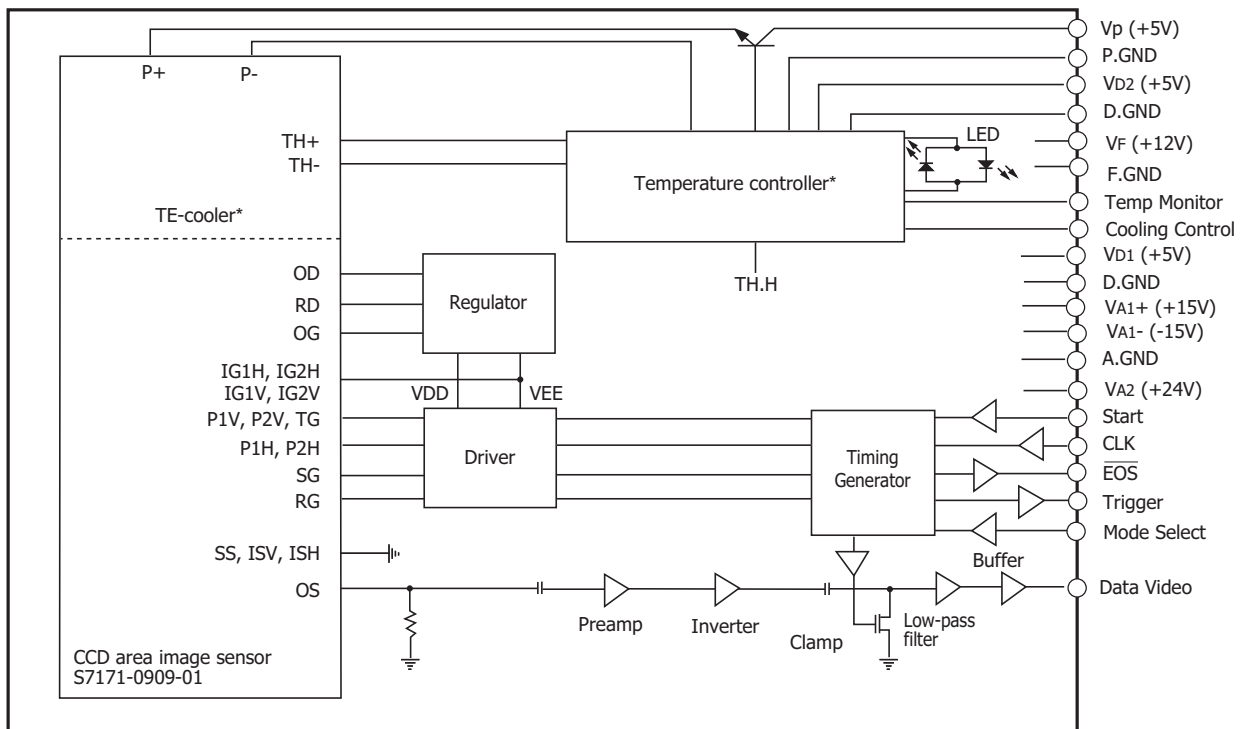

\* The C7180 does not include the temperature controller and TE-cooler.

KACCC0158EC

**Timing chart (line binning operation)**

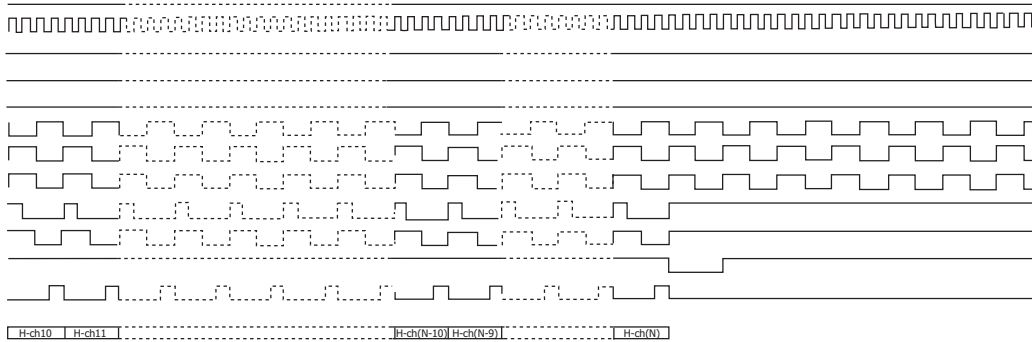
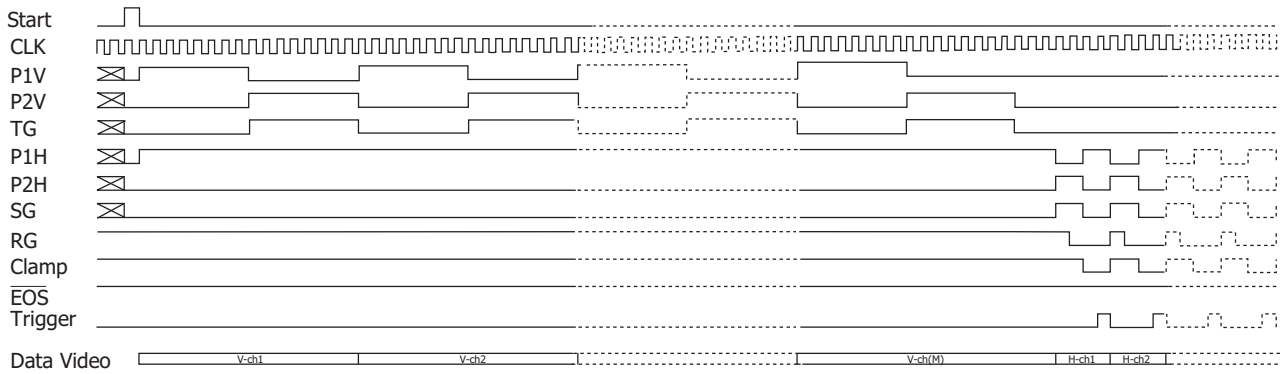

M=520, N=532  
 V-ch1--V-ch4, V-ch (M-3)--V-ch (M): Isolation pixels  
 H-ch1--H-ch4, H-ch (N-3)--H-ch (N): Blank pixels  
 H-ch5--H-ch12, H-ch (N-7)--H-ch (N-4): Isolation pixels

KACCC0635EA

**Pin connections of "SIGNAL I/O" connector**

15-pin D-sub connector

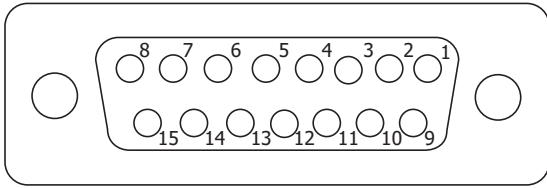

KACCC0069EA

Pin no.	Terminal name	Description
1	Mode select	Digital input signal used to select between the line binning operation and area scanning operation. HCMOS compatible. High level or left open: line binning operation Low level: area scanning operation
2	Data video	Analog video output. Positive polarity.
3	VA1+ (+15 V)	Analog power supply
4	VA1- (-15 V)	Analog power supply
5	VD1 (+5 V)	Digital power supply
6	Start	Digital input signal for initializing the circuit. HCMOS compatible. Positive logic. The interval of the Start pulses determines the integration time of the CCD image sensor.
7	CLK	Digital input signal for operating the circuit. HCMOS compatible. Rising edge operation.
8	$\overline{\text{EOS}}$	Digital output signal for indicating end-of-scan of the image sensor. HCMOS compatible. Negative logic.
9	A.GND	Analog ground
10	A.GND	Analog ground
11	VA2 (+24 V)	Analog power supply
12	D.GND	Digital ground
13	D.GND	Digital ground
14	D.GND	Digital ground
15	Trigger	Digital output signal for A/D conversion. HCMOS compatible. Positive logic.

**Pin connections of "TE CONTROL I/O" connector (C7181)**

9-pin D-sub connector

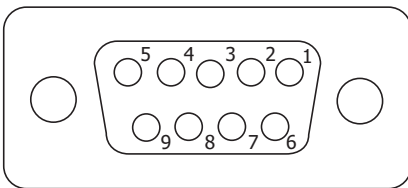

KACCC0075EA

Pin no.	Terminal name	Description
1	VD2 (+5 V)	Digital power supply
2	Temp monitor	Analog output signal of the temperature of the CCD image sensor
3	Cooling control	Digital input signal for starting to cool down. HCMOS compatible. High level or left open: cooling Low level: stand-by
4	Vp (+5 V)	Power supply for the thermoelectric cooler in the CCD image sensor
5	Vf (+12 V)	Power supply for cooling fan
6	D.GND	Ground
7	D.GND	Ground
8	P.GND	Power supply return of the thermoelectric cooler mounted in the CCD image sensor
9	F.GND	Power supply return for cooling fan

Note: Available for using same power supply (+5 V) for "+VD2" and "+Vp"

Dimensional outline (unit: mm)

C7180

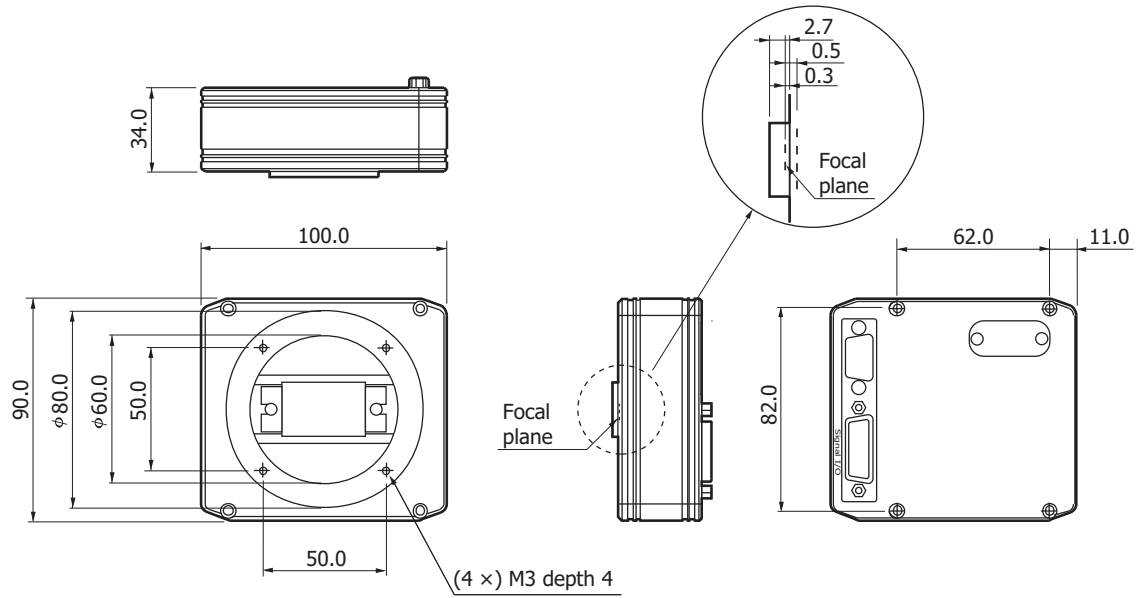

KACCA0107EB

C7181

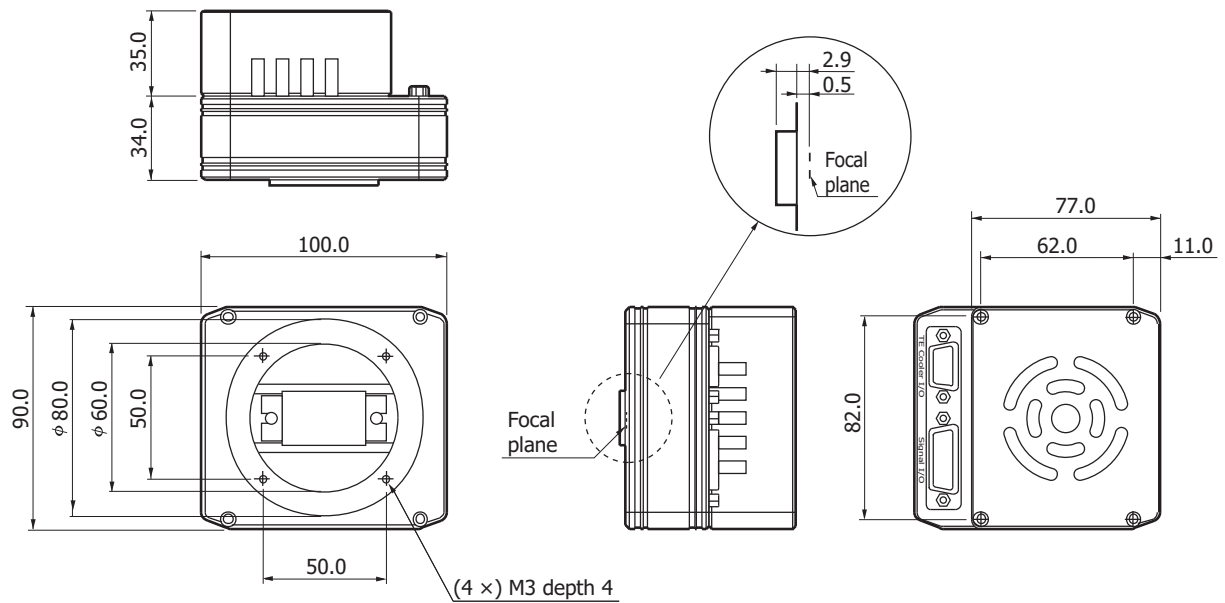

KACCA0108EC

**Pin connections**

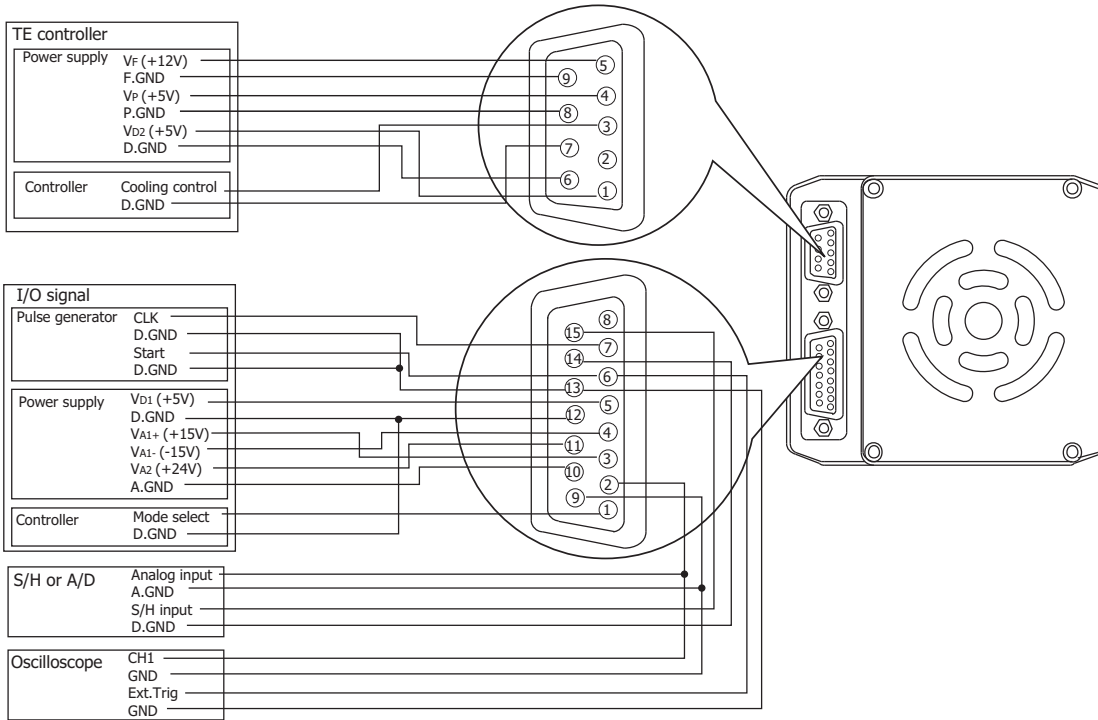

KACCC0076EC

**Related information**

[www.hamamatsu.com/sp/ssd/doc\\_en.html](http://www.hamamatsu.com/sp/ssd/doc_en.html)

- Precautions
- Disclaimer

Multichannel detector head controller C7557-01

When connected to a HAMAMATSU multichannel detector head and a personal computer, the C7557-01 allows easy control of the detector head and data acquisition by using dedicated software that comes with the unit.

**Suitable multichannel detector head**

C7020/-02, C7021/-02, C7025/-02, C7040, C7041, C7043, C7044, C7180, C7181, C8061-01, C8062-01, C10150-01, C10151-01, C5964 series, C8892



**Accessories for C7557-01**

- Spare fuse (2.5 A)\*10
- AC cable
- 2 to 3 conversion adapter
- USB cable
- Detector head connection cables  
(for "SIGNAL I/O" and "TE CONTROL I/O" terminal of multichannel detector head)
- CD-R (MCD USB driver, software, operation manual)
- MOS adapter

\*10: Contained in the holder just above the AC cable connector on the C7557-01 rear panel.

**Connection example**

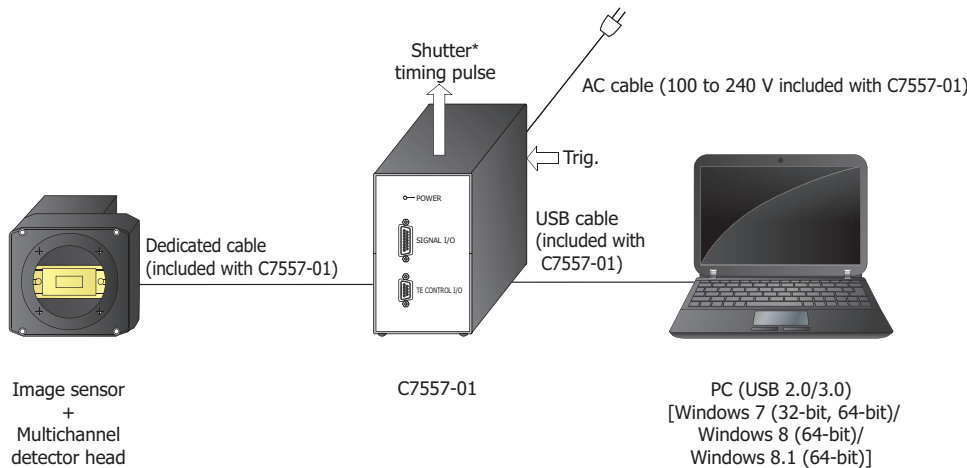

\* Shutter, etc. are not available.

KACCC0402ED

Information described in this material is current as of October 2020.

Product specifications are subject to change without prior notice due to improvements or other reasons. This document has been carefully prepared and the information contained is believed to be accurate. In rare cases, however, there may be inaccuracies such as text errors. Before using these products, always contact us for the delivery specification sheet to check the latest specifications.

The product warranty is valid for one year after delivery and is limited to product repair or replacement for defects discovered and reported to us within that one year period. However, even if within the warranty period we accept absolutely no liability for any loss caused by natural disasters or improper product use. Copying or reprinting the contents described in this material in whole or in part is prohibited without our prior permission.