

MEMS-FPI spectrum sensors, spectroscopic modules

Contents

1. Overview	1
2. MEMS-FPI spectrum sensors	2
2-1 Structure	2
MEMS-FPI tunable filter	2
2-2 Characteristics	3
Absolute maximum ratings	3
Spectral transmittance of the band-pass filter	11
Pull-in phenomenon	13
Temperature characteristics	16
Thermistor characteristics	24
Transmittance of MEMS-FPI tunable filter	26
Incident light aperture angle	27
InGaAs PIN photodiodes	30
2-3 How to use	31
Connection example	31
Evaluation circuit	31
Example of evaluation system	32
Applications	33
3. Spectroscopic modules	34
3-1 Control circuit	34
3-2 Evaluation software	34
3-3 Optical fiber adapter (sold separately)	35
3-4 Characteristics	36
3-5 Measurement example	39
4. Q&A	42

1. Overview

The MEMS-FPI spectrum sensor is an ultra-compact sensor that houses a MEMS-FPI (Fabry-Perot Interferometer) tunable filter that can vary its transmission wavelength by changing the applied voltage and InGaAs PIN photodiode in a single package. The spectral response range covers the near infrared region. It is suitable for installation in compact devices for identifying materials in solutions, plastic, and textile, detecting moisture, and analyzing ingredients in agriculture and food, etc.

The MEMS-FPI spectroscopic module (hereafter called "spectroscopic module") is a compact module that contains a MEMS-FPI spectrum sensor, light source, and control circuit. Spectrum and absorbance can be measured by connecting a PC via USB.

[Figure 1-1] MEMS-FPI spectrum sensor



[Figure 1-2] Spectroscopic module



2. MEMS-FPI spectrum sensors

2-1 Structure

The MEMS-FPI spectrum sensor is composed of a MEMS-FPI tunable filter, photosensor (photodiode), and the like. It has a simple structure in which a MEMS-FPI tunable filter and photosensor is arranged on the same axis as the direction of the incident light. Though this product is a spectral sensor, it uses a single photosensor device and does not require an expensive multichannel photosensor.

[Figure 2-1] Internal structure

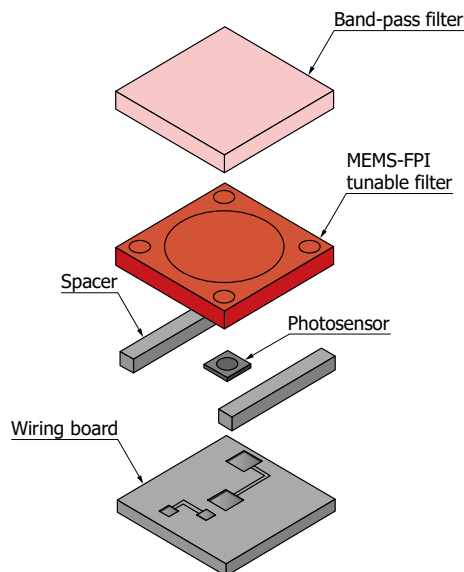

KIRDC0108EC

MEMS-FPI tunable filter

The MEMS-FPI tunable filter has an upper mirror and a lower mirror that are placed opposite each other with an air gap in between them [Figure 2-2]. When a voltage is applied across the mirrors, an electrostatic force is produced to adjust the air gap. To facilitate this action, the upper mirror has a membrane (thin film) structure. If the air gap is $m\lambda/2$ (m : integer), it functions as a filter that allows by and large wavelength λ to pass through. Increasing the filter control voltage shortens the air gap by electrostatic force, causing the peak transmission wavelength to shift to the shorter wavelength side.

Silicon is used as the substrate that serves as an infrared-transmitting filter. The mirrors are designed as multilayered dielectric coatings of SiO_2 , SiN or Poly-Si, which are typical semiconductor materials.

[Figure 2-2] Cross-sectional view of MEMS-FPI tunable filter

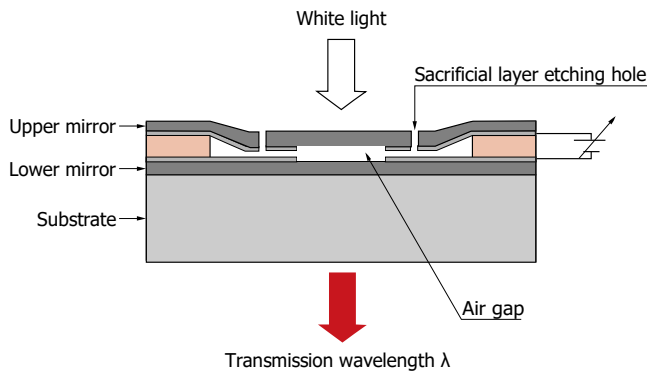

KIRDB0109EA

2-2 Characteristics

Absolute maximum ratings

Exceeding the absolute maximum ratings even momentarily may cause a drop in product quality. Always be sure to use the product within the absolute maximum ratings. The details about filter control voltage are described in "4. Q&A | Q3."

Note: The MEMS-FPI spectrum sensor is an electrostatic sensitive device. When handling the product, precautions need to be taken to avoid damage and deterioration due to static electricity. For details, refer to the instruction manual supplied with the product.

Filter control voltage and peak transmission wavelength

The MEMS-FPI spectrum sensor can vary its peak transmission wavelength based on the filter control voltage, but their relationship is not linear [Figure 2-3].

[Figure 2-3] Peak transmission wavelength vs. filter control voltage (typical example)

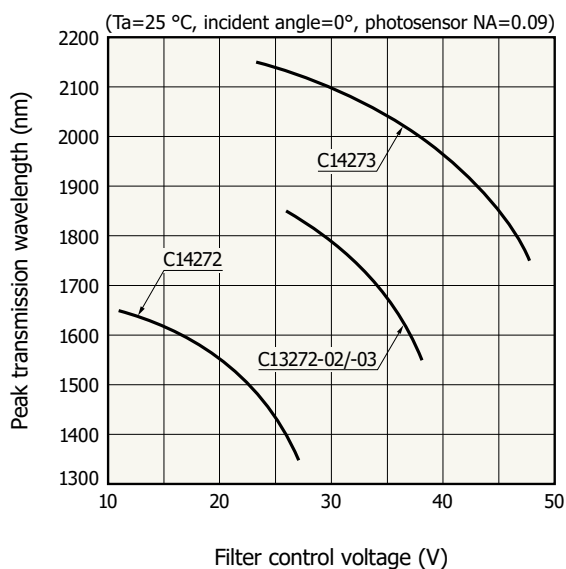

KACCB0482EC

Constants (sensor calibration coefficient) should be estimated by fitting the relation between filter control voltage and peak transmission wavelength with a polynomial. The relationship between filter control voltage and peak transmission wavelength can be expressed by the polynomial below.

The peak transmission wavelength of the MEMS-FPI spectrum sensor has temperature characteristics. For example, if the filter control voltage is tuned to a peak transmission wavelength of 1550 nm at 25 °C on C13272-03, and the temperature goes up to 45 °C in this state, the peak transmission wavelength is to be shifted

to 1562 nm (about 12 nm wavelength shift from 1550 nm). The relationship between the filter control voltage and the peak transmission wavelength is expressed by the method using the room temperature compensation constant and the method using the temperature compensation constant.

〈At room temperature〉

The relationship between the filter control voltage and the peak transmission wavelength is expressed by the equation (2-1) when the temperature of the MEMS-FPI spectrum sensor can be kept at room temperature (25 °C).

$$V^2 = a_0 \lambda p^5 + b_0 \lambda p^4 + c_0 \lambda p^3 + d_0 \lambda p^2 + e_0 \lambda p + f_0 \cdots (2-1)$$

V: filter control voltage

λp : peak transmission wavelength [m]

You can calculate constants $a_0, b_0, c_0, d_0, e_0, f_0$ by using equations (2-2) to (2-12) using the room temperature compensation constants a, b, c, g in the reference datasheet and the fixed value A for each type no. of the product.

Note:

- The filter control voltage calculated by equation (2-1) is reference data. There is no guarantee.
- a, b, c, g (conditions: $T_a=25$ ° C, spectral response range) are different for each product.

$$C14272: Z = 1.5 \times 10^{-6} (1 - A), C13272-02/-03: Z = 1.7 \times 10^{-6} (1 - A), C14273: Z = 1.95 \times 10^{-6} (1 - A) \cdots (2-2)$$

$$B_0 = -a \cdots (2-3)$$

$$C_0 = 3ag + b \cdots (2-4)$$

$$D_0 = -3ag^2 - 2bg - c \cdots (2-5)$$

$$E_0 = ag^3 + bg^2 + cg \cdots (2-6)$$

$$a_n = A^5 B_n \cdots (2-7)$$

$$b_n = A^4 (5B_n Z + C_n) \cdots (2-8)$$

$$c_n = A^3 (10B_n Z^2 + 4C_n Z + D_n) \cdots (2-9)$$

$$d_n = A^2 (10B_n Z^3 + 6C_n Z^2 + 3D_n Z + E_n) \cdots (2-10)$$

$$e_n = AZ (5B_n Z^3 + 4C_n Z^2 + 3D_n Z + 2E_n) \cdots (2-11)$$

$$f_n = Z^2 (B_n Z^3 + C_n Z^2 + D_n Z + E_n) \cdots (2-12)$$

$$C14272: A=1/0.755121951$$

$$C13272-02/-03: A=1/0.753902939$$

$$C14273: A=1/0.751250854$$

We can calculate $a_0, b_0, c_0, d_0, e_0, f_0$ by substituting $n=0$ to equations (2-7) through (2-12). Substituting these values into equation (2-1) gives the filter control voltage corresponding to the peak transmission wavelength. Figure 2-4 shows measurement examples of the deviation between the peak transmission wavelength measured at 25 ° C by applying a specific filter control voltage and the peak transmission wavelength calculated by the equation of this method. The deviation is within ± 0.5 nm.

[Figure 2-4] Peak transmission wavelength precision
(measurement example using room temperature compensation constant)

(a) C14272 (number of samples: 409)

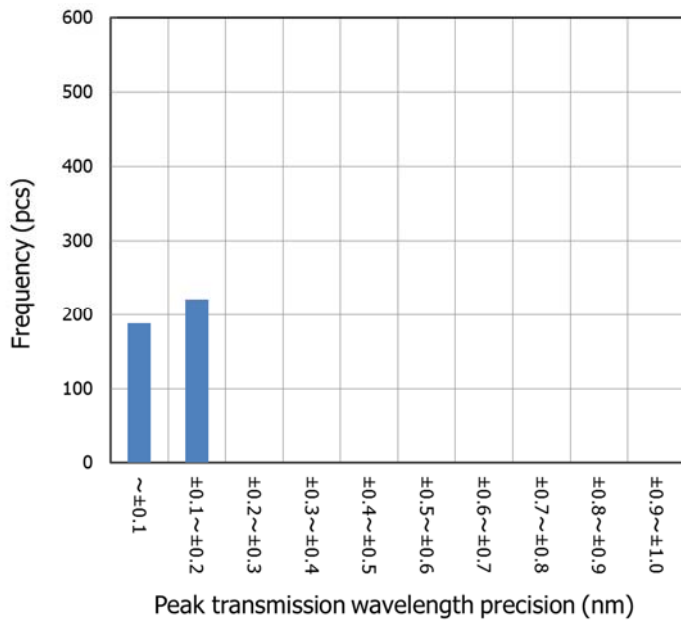

(b) C13272-02/-03 (number of samples: 952)

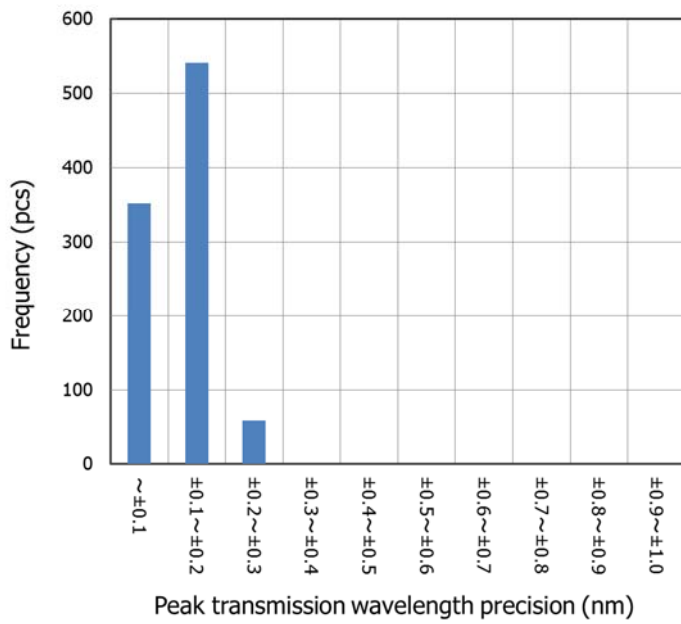

(c) C14273 (number of samples: 625)

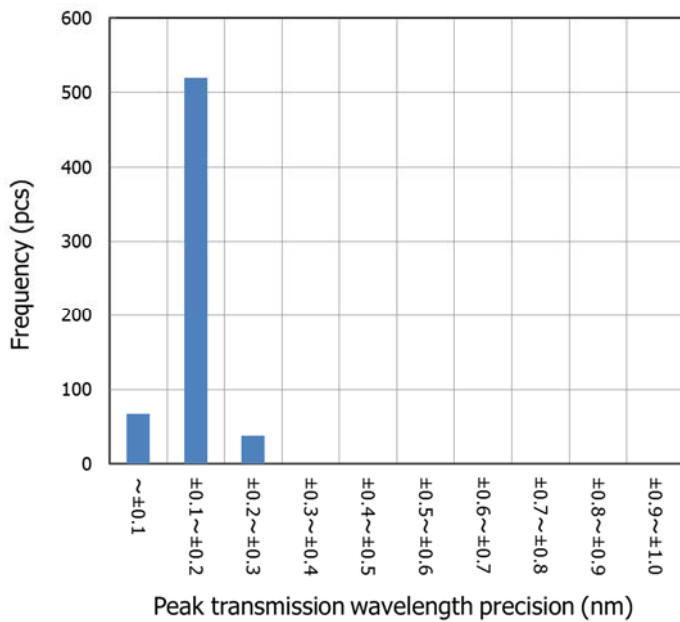

〈Compensation of temperature characteristics' differences of filter control voltage and peak transmission wavelength〉

This section explains how to compensate the change in peak transmission wavelength due to temperature change to several nm or less by using equations. The relationship between the filter control voltage and the peak transmission wavelength is expressed by equation (2-17). The calculation is done by adding the temperature change to equation (2-1) at room temperature.

Complex formulas are used, so we have prepared an Excel® sheet for calculations. Contact us for detailed information.

Note: Excel is either registered trademark or trademark of Microsoft Corporation in the United States and/or other countries.

$$B_1 = -p, B_2 = -t \cdots(2-13)$$

$$C_1 = 3pg + q, C_2 = 3tg + u \cdots(2-14)$$

$$D_1 = -3pg^2 - 2qg - r, D_2 = -3tg^2 - 2ug - v \cdots(2-15)$$

$$E_1 = pg^3 + qg^2 + rg + s, E_2 = tg^3 + ug^2 + vg + w \cdots(2-16)$$

p, q, r, s, t, u, v, w: temperature correction constant in the reference datasheet

$$V^2 = a_0\lambda p^5 + b_0\lambda p^4 + c_0\lambda p^3 + d_0\lambda p^2 + e_0\lambda p + f_0 + (a_1\lambda p^5 + b_1\lambda p^4 + c_1\lambda p^3 + d_1\lambda p^2 + e_1\lambda p + f_1) \Delta T + (a_2\lambda p^5 + b_2\lambda p^4 + c_2\lambda p^3 + d_2\lambda p^2 + e_2\lambda p + f_2) \Delta T^2 \cdots(2-17)$$

V: filter control voltage

λp : peak transmission wavelength [m]

ΔT : temperature change for 25 ° C (T - 25 °C)

" $a_0, b_0, c_0, d_0, e_0, f_0$ " " $a_1, b_1, c_1, d_1, e_1, f_1$ " " $a_2, b_2, c_2, d_2, e_2, f_2$ ": Each constant is derived from equations (2-7) (2-8) (2-9) (2-10) (2-11) (2-12).

Since it takes a long time to measure the temperature characteristics of all samples, we recommend that you

correct temperature by using the temperature compensation constant shown in the reference datasheet for products with similar characteristics, such as the same lot. Figure 2-5 shows measurement examples of the deviation between the measured peak transmission wavelength and the peak transmission wavelength calculated using the temperature compensation constants.

The above temperature compensation constants were obtained under Hamamatsu 's evaluation conditions. The constants cannot be guaranteed under your conditions of use.

[Figure 2-5] Peak transmission wavelength precision

(measurement example using temperature compensation constant)

(a) C14272 (+5 to +45 °C: deviation=within ± 0.6 nm, number of samples: 22)

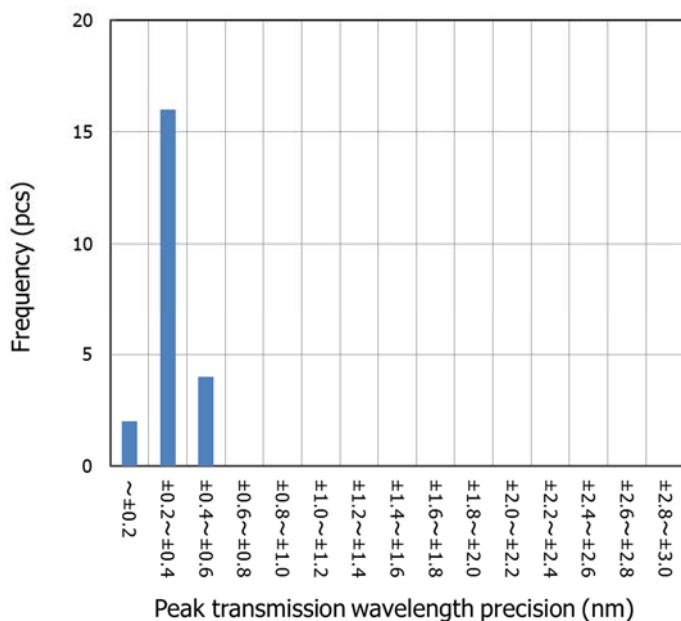

(b) C14272 (-20 to +85 °C: deviation=within ± 1.6 nm, number of samples: 22)

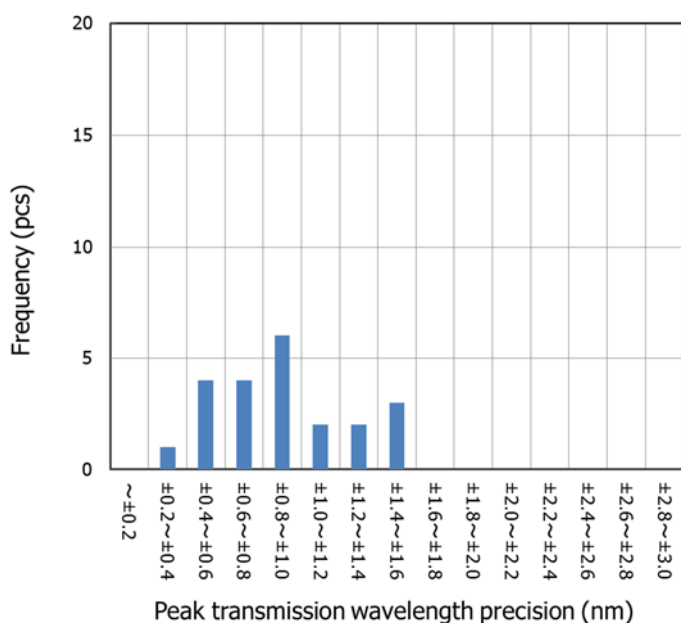

(c) C13272-02/-03 (+5 to +45 °C: deviation=within ± 0.6 nm, number of samples: 20)

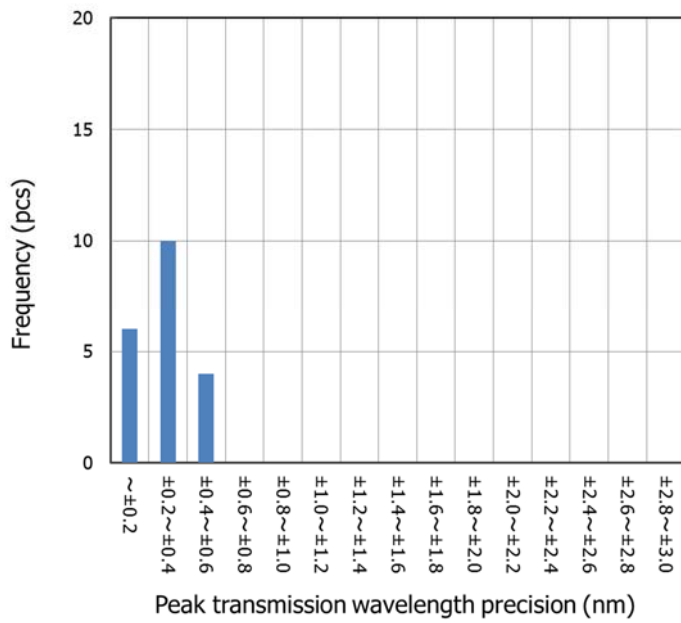

(d) C13272-02/-03 (-20 to +85 °C: deviation=within ± 1.2 nm, number of samples: 20)

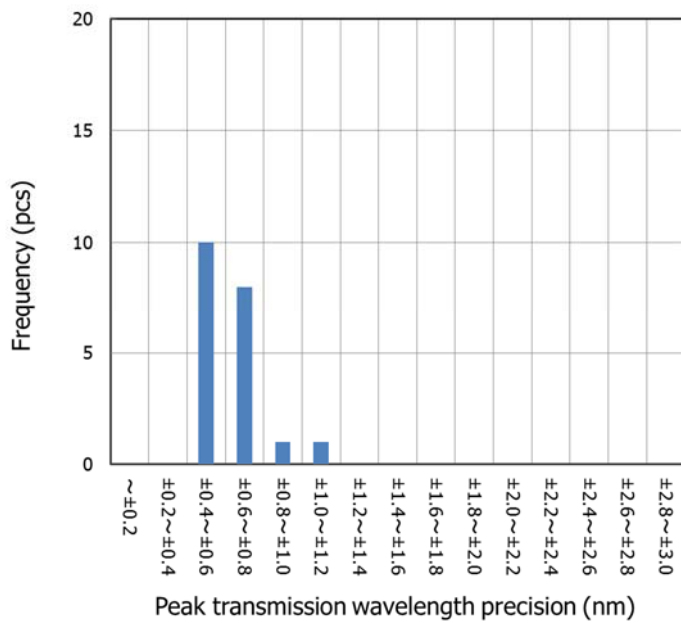

(e) C14273 (+5 to +45 °C: deviation=within ± 0.8 nm, number of samples:24)

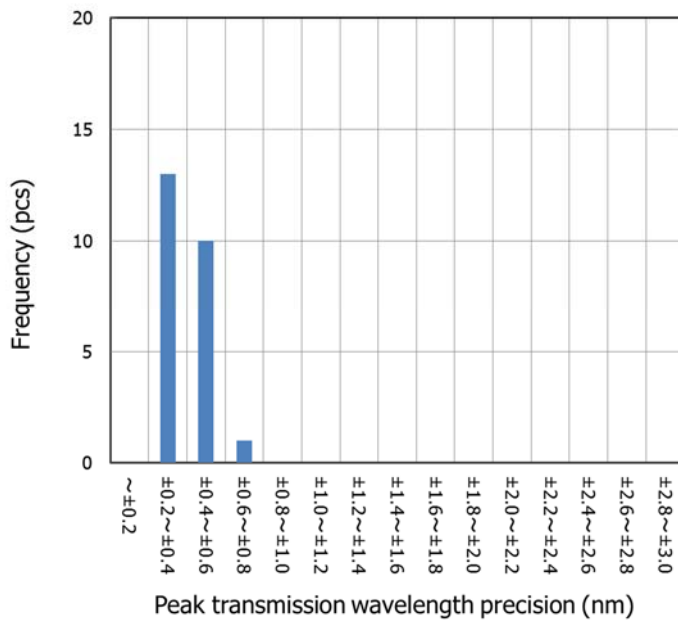

(f) C14273 (-20~+85 °C: deviation=within ± 1.8 nm, number of samples: 24)

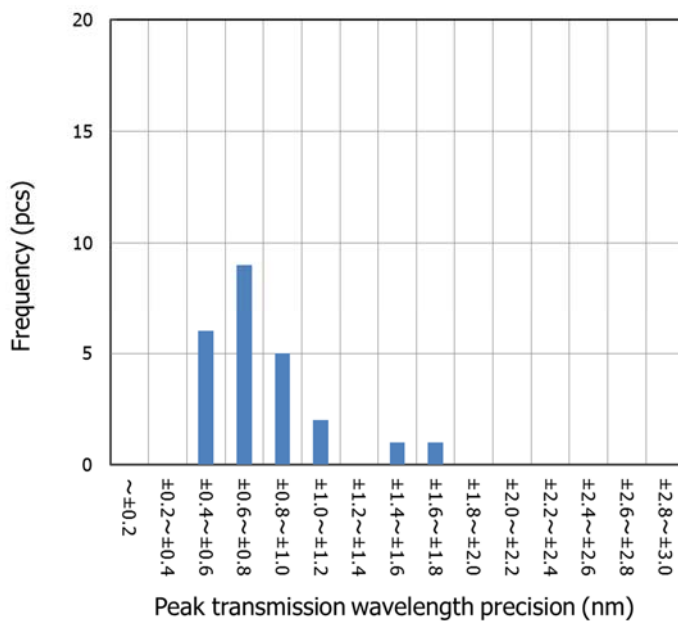

〈When using evaluation circuit C13294-02〉

When using Hamamatsu evaluation circuit C13294-02 for MEMS-FPI spectrum sensor, the calculated constants (sensor calibration coefficient) are used by fitting the relationship between the filter control voltage and the peak transmission wavelength with a 7th order polynomial. This polynomial allows the peak transmission wavelength to be calculated from the filter control voltage. Note that the C13294-02 does not support temperature compensation.

• Fitting example

Fitting is to be done by 7th order polynomial [equation (2-18)].

$$\lambda = a_0 + a_1 \cdot V + a_2 \cdot V^2 + a_3 \cdot V^3 + a_4 \cdot V^4 + a_5 \cdot V^5 + a_6 \cdot V^6 + a_7 \cdot V^7 \dots (2-18)$$

λ : peak transmission wavelength
 V : filter control voltage

8 or more points of filter control voltage and peak transmission wavelength are needed to measure for estimating the constants a_0 to a_7 . A difference between a measurement value of peak transmission wavelength and its approximate value can be reduced by setting the filter control voltage at an equal interval.

As a typical example, fitting using the C13272-03 is shown in Table 2-1. The constants used for Table 2-1 fitting are shown in Table 2-2.

Note: The constants a_0 to a_7 are eigenvalues of an individual product, and these values are valid for the spectral response range only. Values calculated by equation (2-18) are just for reference, and not for guarantee. Constants a_0 through a_7 are stored for each serial number in the supplied CD-R. This is a text format that can be read by the software that comes with the evaluation kit C13294-02 (sold separately) for MEMS-FPI spectrum sensor.

[Table 2-1] Typical example of fitting (C13272-03)

Filter control voltage (V)	Peak transmission wavelength (nm)		
	Measurement value	Approximate value	Approximate value - Measurement value
25.97	1850.0	1850.0	0
28	1822.5	1822.5	0
30	1790.7	1790.6	-0.1
32	1752.5	1752.6	0.1
34	1705.7	1705.7	0
36	1645.7	1645.7	0
37	1607.7	1607.7	0
38	1560.9	1560.9	0
38.2	1550.0	1550.1	0.1

[Table 2-2] Constants used in fitting (Table 2-1) (sensor calibration coefficient, C13272-03, typical example)

Constant	Value
a_0	$-9.51514760322744 \times 10^3$
a_1	0
a_2	$2.57814337882524 \times 10^2$
a_3	$-2.80146849748198 \times 10^1$
a_4	$1.36625505884324 \times 10^0$
a_5	$-3.54779093794269 \times 10^{-2}$
a_6	$4.79158749439675 \times 10^{-4}$
a_7	$-2.66075731674161 \times 10^{-6}$

When a calculation is performed by substituting the constants of Table 2-2 into equation (2-18), the relationship between the peak transmission wavelength and filter control voltage become equivalent to that shown in Figure 2-3.

Spectral resolution

The spectral resolution of the MEMS-FPI spectrum sensor is defined based on the full width at half maximum of the spectrum [Figure 2-6]. It is defined as the spectrum span at the 50% level of the spectrum peak value. Figure 2-7 shows a measurement example of the spectral resolution of a MEMS-FPI spectrum sensor.

[Figure 2-6] Definition of full width at half maximum

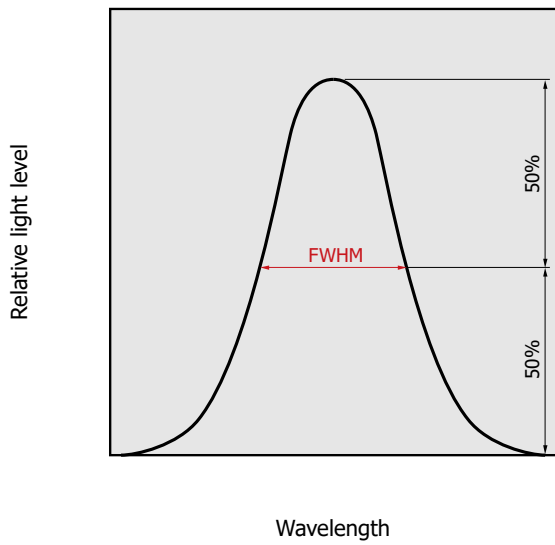

KACCC0320EB

[Figure 2-7] Spectral resolution vs. peak transmission wavelength (typical example)

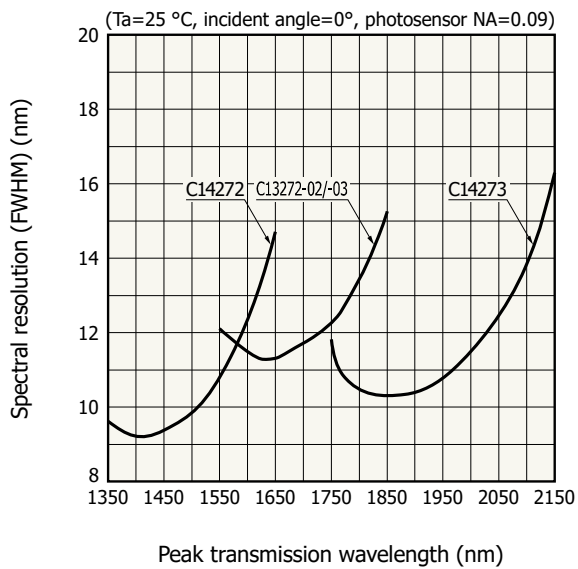

KACCB0483EC

Spectral transmittance of the band-pass filter

The MEMS-FPI spectrum sensor has a built-in band-pass filter for cutting off wavelengths outside the spectral response range. Figure 2-8 shows the spectral transmittance characteristics of the band-pass filter.

[Figure 2-8] Spectral transmittance characteristics of built-in band-pass filter (typical example)
(a) C14272

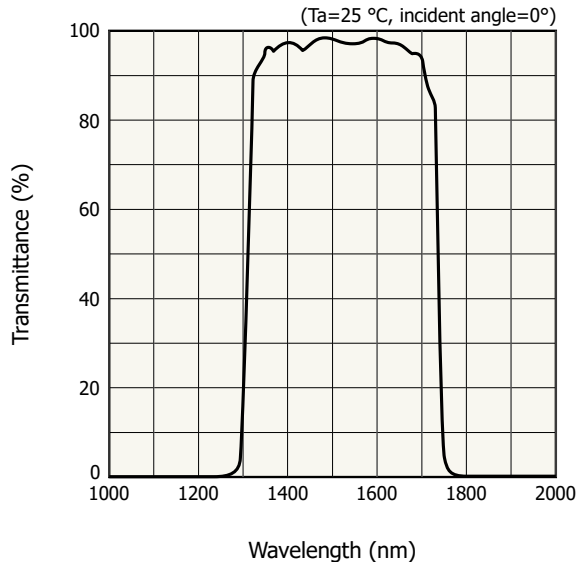

KACCB0476EB

(b) C13272-02/-03

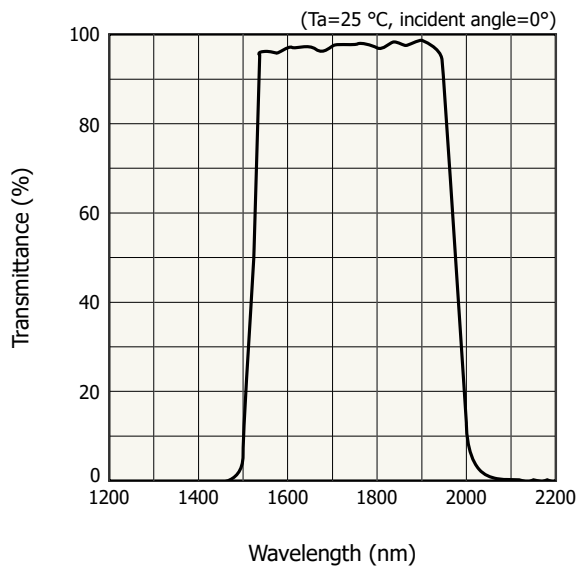

KACCB0433EB

(c) C14273

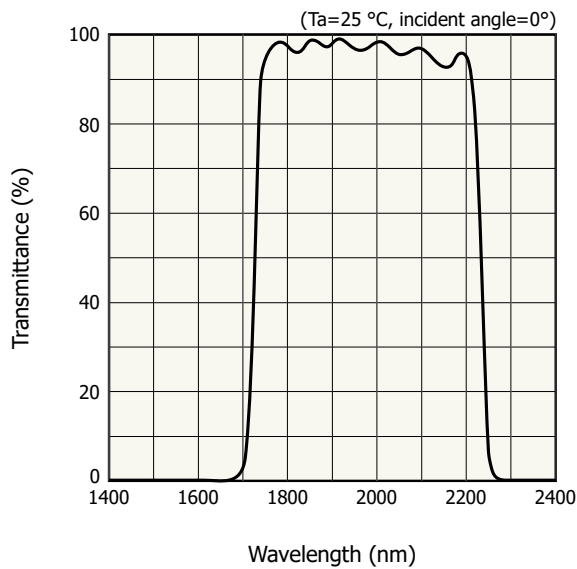

KACCB00507EA

Pull-in phenomenon

When operating a MEMS-FPI tunable filter, the so-called pull-in phenomenon should be taken into account. The pull-in phenomenon occurs when the balance between the electrostatic attractive force pulling the mirrors together by an electric field and the force of the springs on the upper mirror is thrown off. Normally, when these forces are in balance, the position of the upper mirror of the MEMS-FPI tunable filter is set, and the wavelength matching the air gap can be transmitted. However, if the filter control voltage increases to a given voltage, the electrostatic attractive force becomes stronger than the force of the springs. This causes the balance of forces to be thrown off, and the upper mirror sticks to the lower mirror. This is the pull-in phenomenon. If the upper mirror sticks to the lower mirror, it cannot be easily separated. To avoid this, the filter control voltage must be carefully adjusted when operating the MEMS-FPI tunable filter. The air gap at which a pull-in phenomenon occurs is about 2/3 of the initial air gap.

A relation between filter control voltage and peak transmission wavelength of the MEMS-FPI tunable filter is shown in Figure 2-9. The pull-in phenomenon should occur when an air gap becomes about 2/3 of an initial state at 0 V in the filter control voltage, and peak transmission wavelengths should be shifted sharply (broken line part). High accuracy of the filter control voltage is important, and due attention should be paid on an operation condition close to the pull-in phenomenon occurrence. The filter control voltage causing the pull-in phenomenon differs from unit to unit, which should be noted.

Furthermore, the pull-in phenomenon does not occur at the filter control voltage's absolute maximum rating or below, so the filter control voltage has to be set at a lower value than that of the absolute maximum rating.

[Figure 2-9] Pull-in phenomenon (broken line part)
(a) C14272

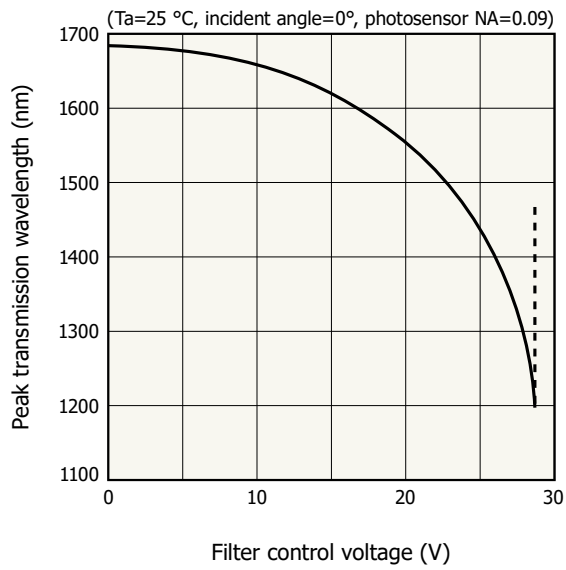

KACCB0484EA

(b) C13272-02/-03

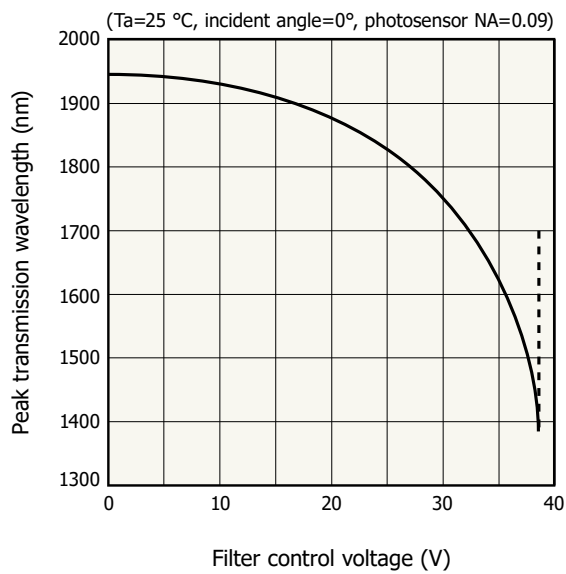

KACCB0442EA

(c) C14273

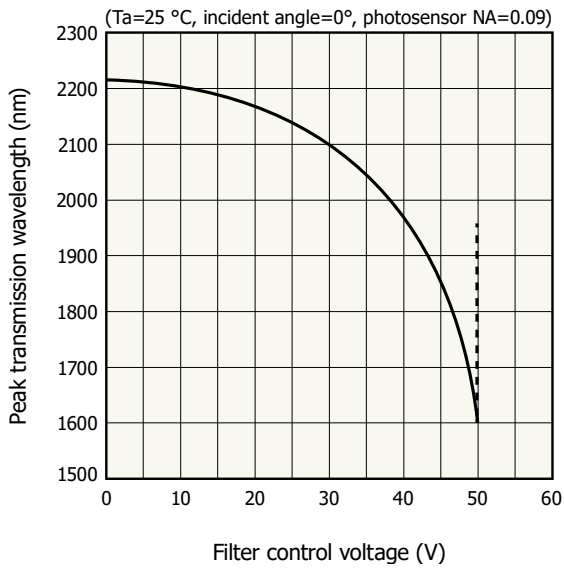

KACCB0518EB

A voltage value where the pull-in phenomenon occurs changes with temperature, which should be noted. A temperature characteristic of the pull-in phenomenon is shown in Figure 2-10.

[Figure 2-10] Temperature dependence of pull-in phenomenon (typical example)

(a) C14272

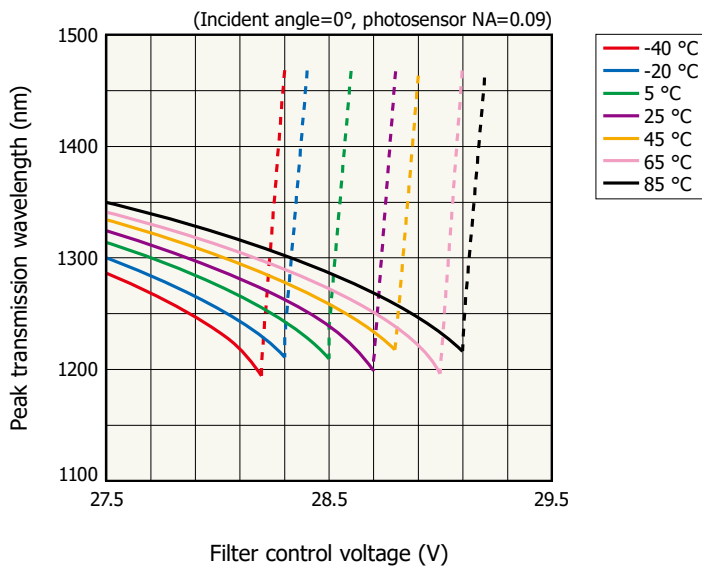

KACCB0485EA

(b) C13272-02/-03

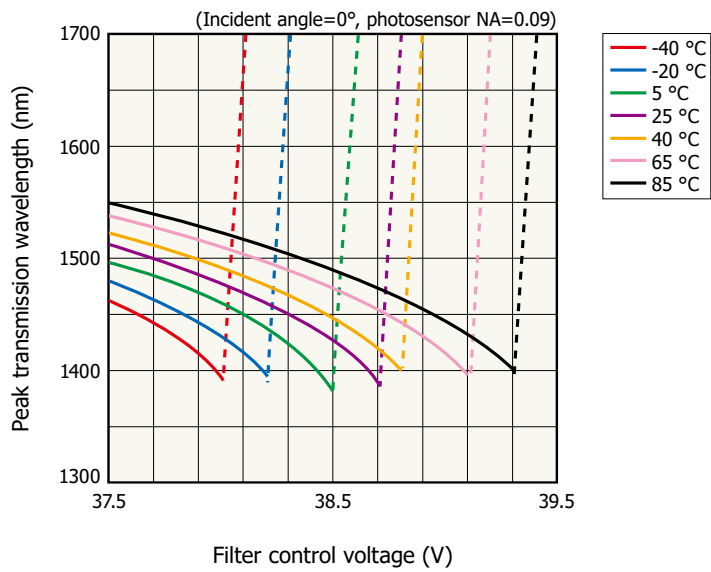

KACCB0443EA

(c) C14273

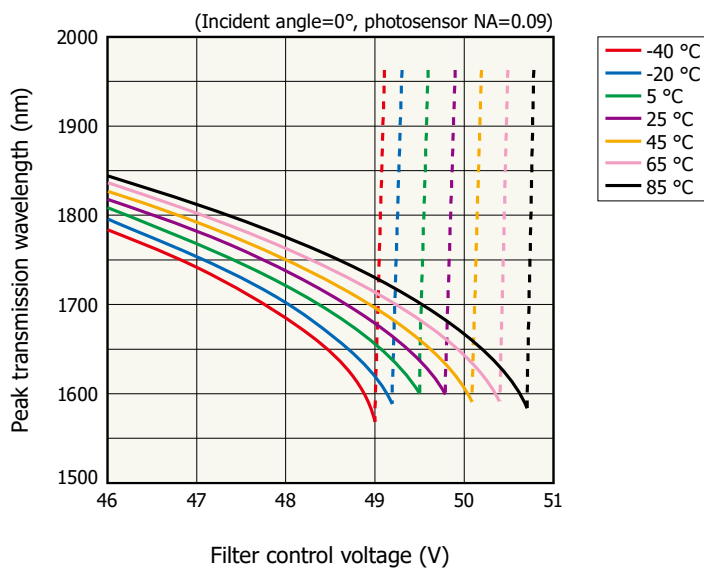

KACCB0519EA

Temperature characteristics

A peak transmission wavelength of a MEMS-FPI spectrum sensor has temperature dependence.

- C14272: 0.3 nm/°C typ. ($\lambda=1500$ nm)
- C13272-02/-03: 0.4 nm/°C typ. ($\lambda=1700$ nm)
- C14273: 0.3 nm/°C typ. ($\lambda=1950$ nm)

A relation between peak transmission wavelength and ambient temperature at filter control voltage kept constant is shown in Figure 2-11.

[Figure 2-11] Peak transmission wavelength vs. ambient temperature (typical example)
 (a) C14272

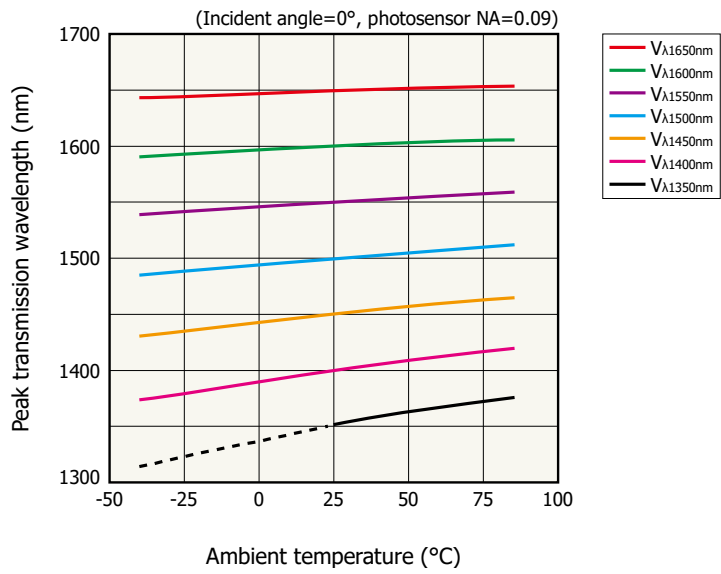

KACCB0474EA

(b) C13272-02/-03

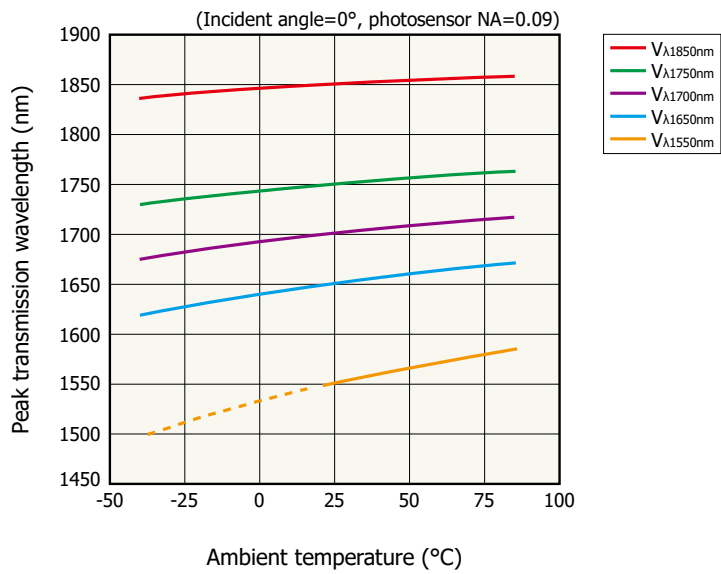

KACCB0403EC

(c) C14273

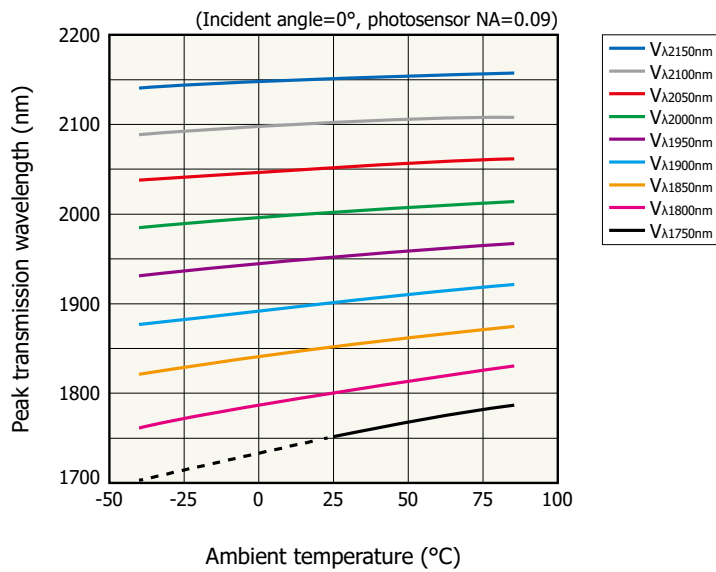

KACCB0505EA

Furthermore, peak transmission wavelength shifts at the temperature changes [low temperature side (-40→+25 °C) and high temperature side (+25→+85 °C)] are shown in Figure 2-12, where the estimation is done by using Figure 2-11 data. A wavelength shift becomes greater at a shorter peak transmission wavelength, and also that at a low temperature side is greater than that at a high temperature side. The broken line range of Figure 2-11 and Figure 2-12 corresponds to data when the built-in band-pass filter is removed.

The peak transmission wavelength cannot be detected accurately in the broken line range of Figure 2-11 and Figure 2-12. This is because when the ambient temperature is less than 25 °C, the peak transmission wavelength of the MEMS-FPI tunable filter is outside the transmission wavelength range of the band-pass filter.

[Figure 2-12] Peak transmission wavelength shift vs. peak transmission wavelength (typical example)
(a) C14272

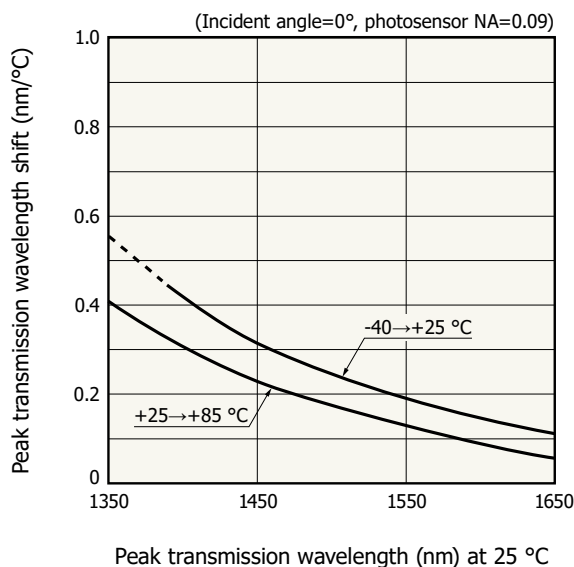

KACCB0486EA

(b) C13272-02/-03

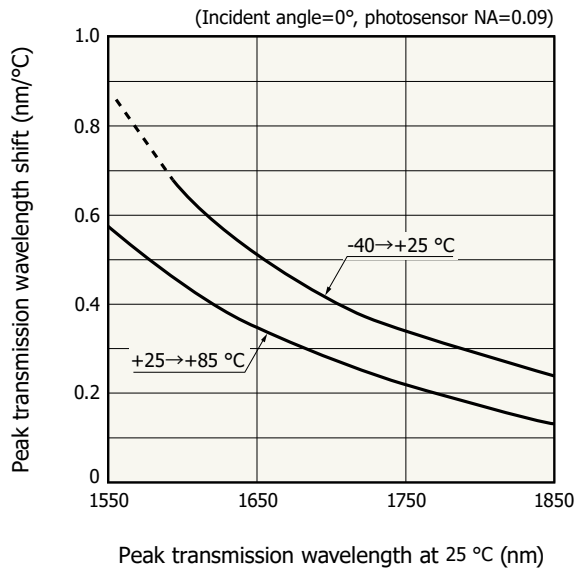

KACCB0444EA

(c) C14273

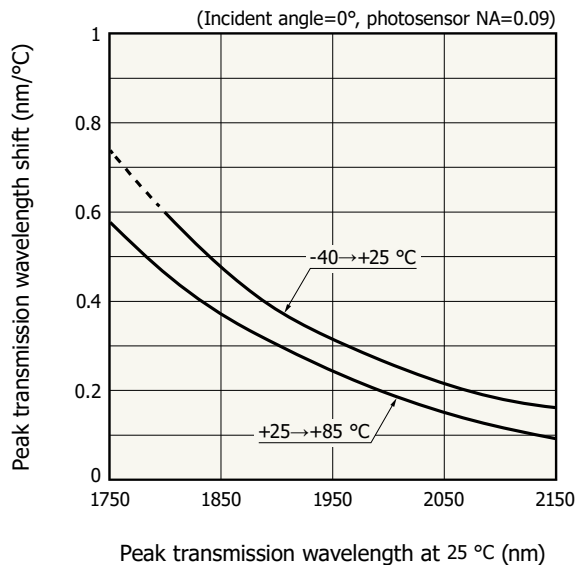

KACCB0520EA

Temperature characteristics of wavelength profile at the MEMS-FPI spectrum sensor's filter control voltage kept constant is shown in Figure 2-13.

Transmittance of a band-pass filter built in the sensors is inserted (transmittance of band-pass filter is hardly dependent on temperature). A wavelength profile is shifted to a shorter side by having ambient temperature be lower. A peak transmission wavelength becomes hard to detect with high accuracy at 25 °C or lower because the wavelength profile is in a region of low transmittance of the band-pass filter.

[Figure 2-13] Temperature characteristics of wavelength profile (typical example)
 (a) C14272

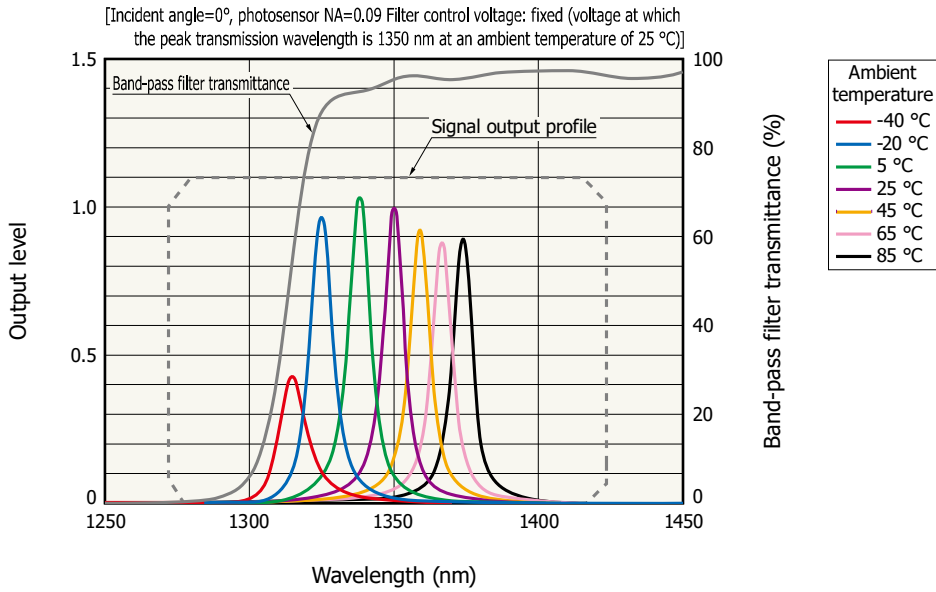

KACCB0487EA

(b) C13272-02/-03

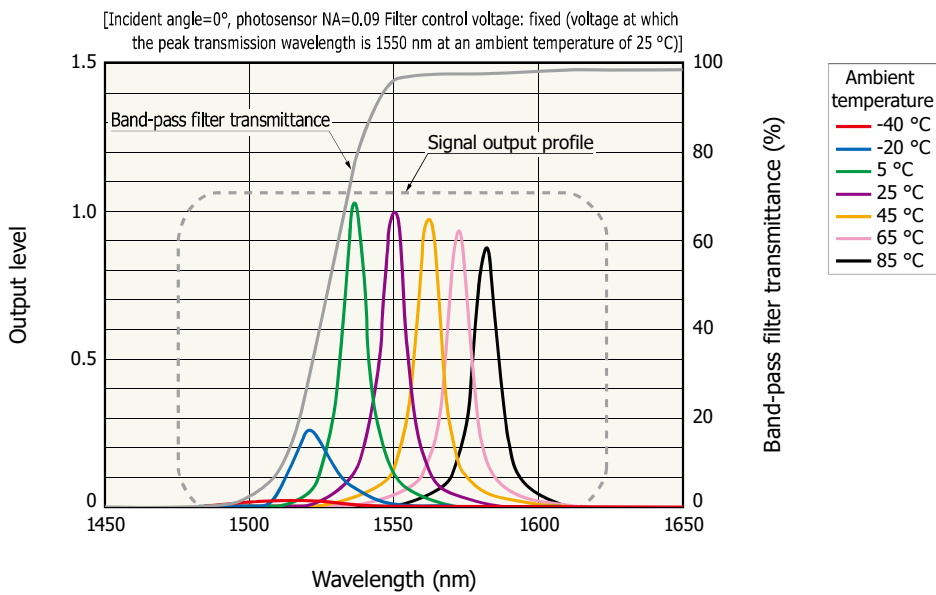

KACCB0445EB

(c) C14273

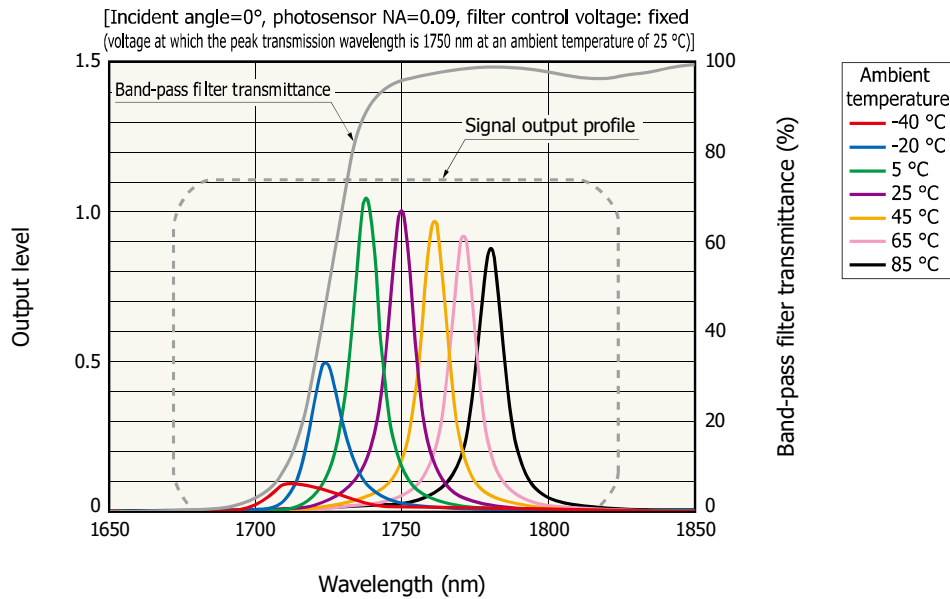

KACCB0521EA

Peak transmission wavelength detection with high accuracy is to be possible with little influence from a band-pass filter by compensation of filter control voltage to ambient temperature, which is within an operating temperature range (-40 to +85 °C) and a spectral response range. A relation between filter control voltage and ambient temperature is shown in Figure 2-14. Filter control voltage shifts [calculated with Figure 2-14 data and equation (2-19)] at the temperature changes [low temperature side (-40→+25 °C) and high temperature side (+25→+85 °C)] are shown in Figure 2-15. A filter control voltage shift becomes smaller at a shorter peak transmission wavelength, and that at a low temperature side is greater than that at a high temperature side. Close attention should be paid to the pull-in phenomenon particularly at a short wavelength range or at low temperature.

[Figure 2-14] Filter control voltage vs. ambient temperature (typical example)
(a) C14272

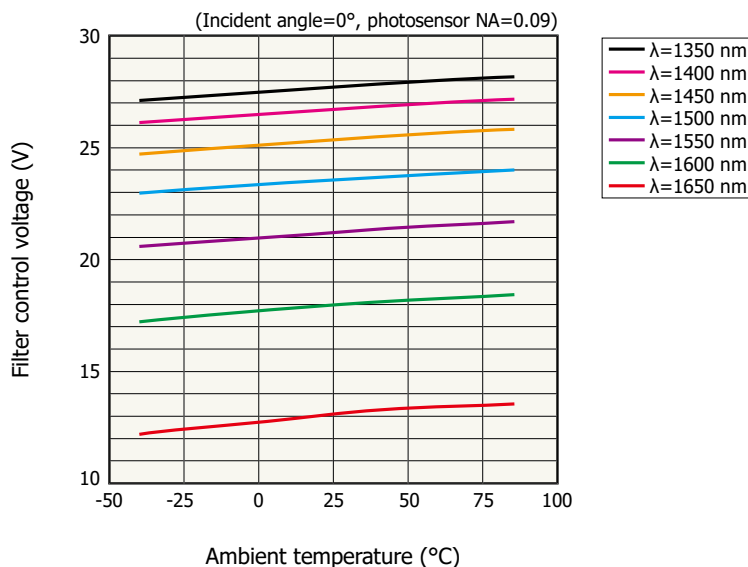

KACCB0475EB

(b) C13272-02/-03

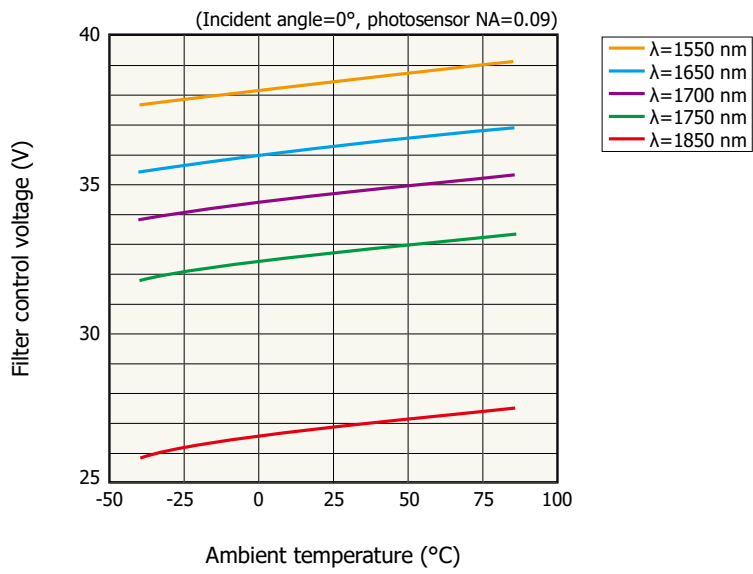

KACCB0432EC

(c) C14273

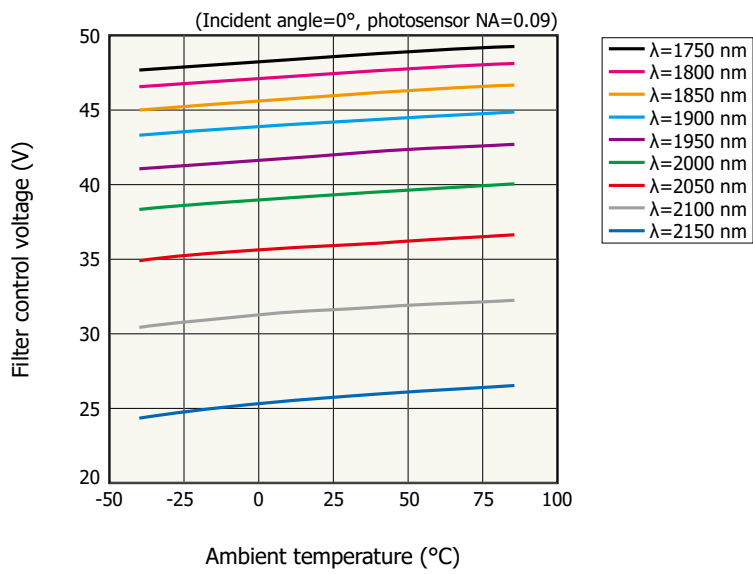

KACCB0506EB

[Figure 2-15] Filter control voltage shift vs. peak transmission wavelength (typical example)
 (a) C14272

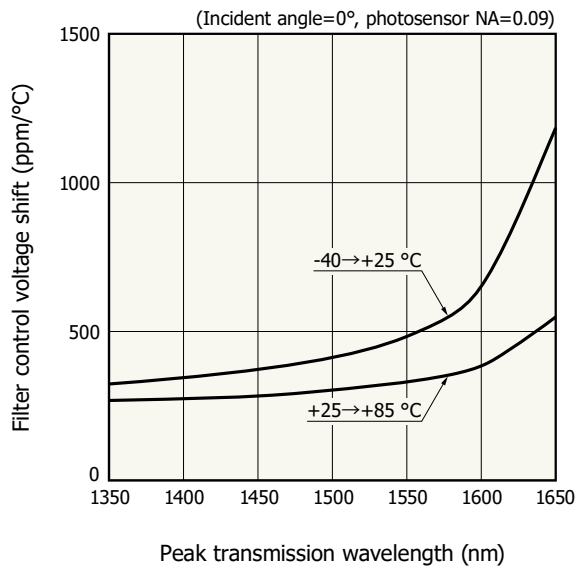

(b) C13272-02/-03

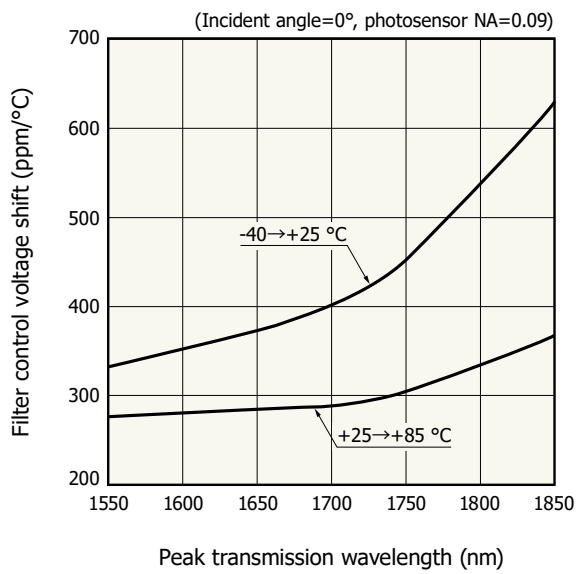

(c) C14273

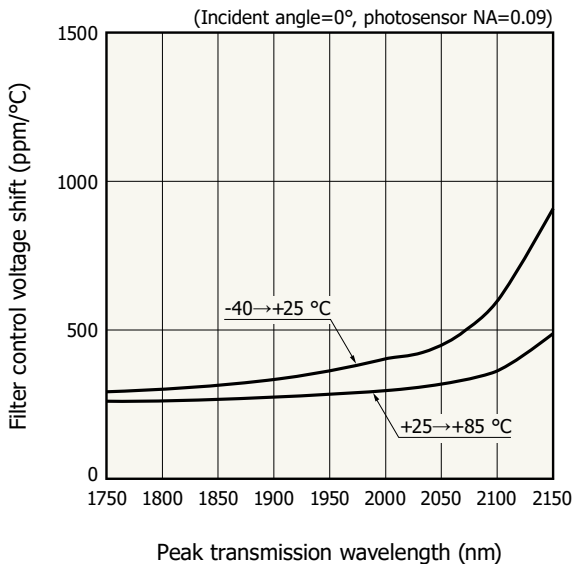

KACCB0522EA

How to calculate filter control voltage shift is shown in equation (2-19).

$$\text{Filter control voltage shift} = \frac{(V - V_0)}{(T - T_0)} V_0 \times 10^6 \text{ [ppm/°C]} \dots (2-19)$$

T: ambient temperature

T₀: ambient temperature (25 °C)

V: filter control voltage

V₀: filter control voltage (25 °C)

Thermistor characteristics

A relation between thermistor resistance and temperature is shown in Figure 2-16.

[Figure 2-16] Thermistor resistance vs. temperature (typical example)

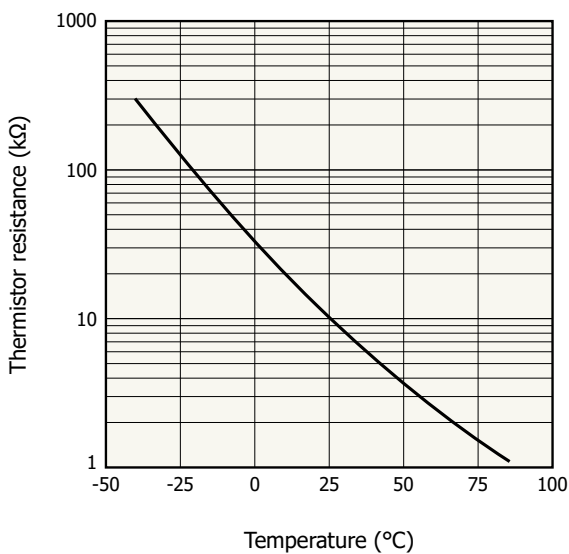

KACCB0404EB

A value of thermistor resistance can be converted into temperature by using Steinhart-Hart equation (2-20).

$$1/T = A + B[\ln(R)] + C[\ln(R)]^3 \dots (2-20)$$

T: temperature [K]
 R: thermistor resistance (Ω)

The precision of conversion can be improved by estimating the constants A, B and C of equation (2-20) with limiting a range of resistance values. An example is shown in Table 2-3 for reference.

[Table 2-3] Constants of Steinhart-Hart equation (reference example)

Resistance range (k Ω)	Constant		
	A	B	C
(300.3) to 96.1	3.53348×10^{-3}	-7.87463×10^{-5}	8.74259×10^{-7}
96.1 to 32.9	1.46516×10^{-3}	1.85960×10^{-4}	2.32844×10^{-7}
32.9 to 5.3	1.09316×10^{-3}	2.40113×10^{-4}	6.28813×10^{-8}
5.3 to (1.1)	1.05955×10^{-3}	2.44870×10^{-4}	5.14556×10^{-8}

A value of thermistor resistance is converted into temperature by using equation (2-20) on the C13294-02 evaluation circuit for MEMS-FPI spectrum sensor (sold separately).

The following is an example of temperature measurement using thermistor resistance. Figure 2-17 shows the difference between the measured ambient temperature and the temperature calculated by dividing -20 to +85 °C into three temperature ranges, and calculating the constants A, B, and C by measuring each 30 samples.

[Figure 2-17] Difference in temperature between actual measurement and conversion from thermistor resistance values (measurement example, number of samples: 30)

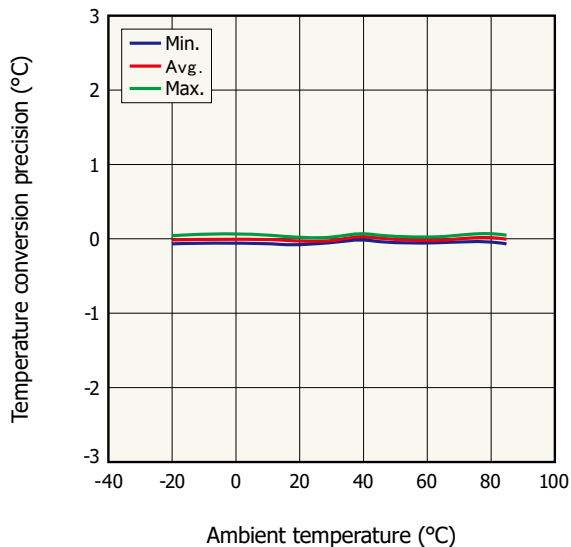

KACCB0523EA

An example of a certain tendency coming from a common lot, etc. is hereby shown. For 30 samples, the constants A, B, and C are determined over three temperature ranges, and average values (A', B', and C') of the 30 samples are estimated. The differences between the measured value and the temperature calculated from the constants A', B', and C' are shown in Figure 2-18. This is inferior to performing temperature conversion individually on the accuracy, but it enables calibration in a short time.

[Figure 2-18] Difference in temperature between actual measurement and conversion from thermistor resistance values (measurement example, calculated from an average constant, number of samples: 30)

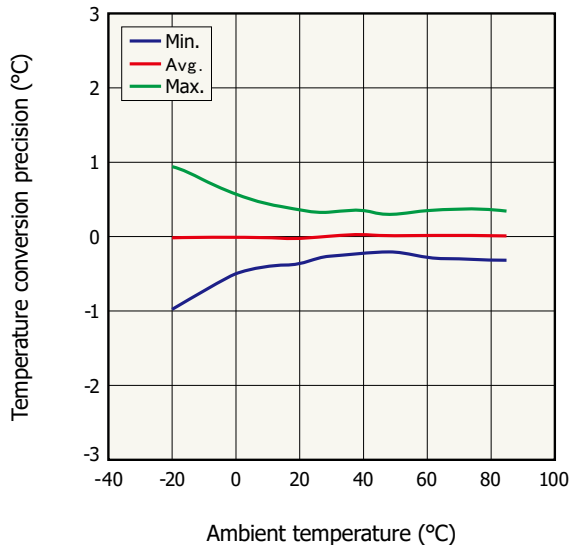

KACCB0524EA

Transmittance of MEMS-FPI tunable filter

The transmittance characteristic of a MEMS-FPI tunable filter is shown in Figure 2-19. The transmittance peak over a spectral response range is more than 50%. It is noted its characteristic differs from unit to unit.

[Figure 2-19] Transmittance of MEMS-FPI tunable filter vs. wavelength (typical example)
(a) C14272

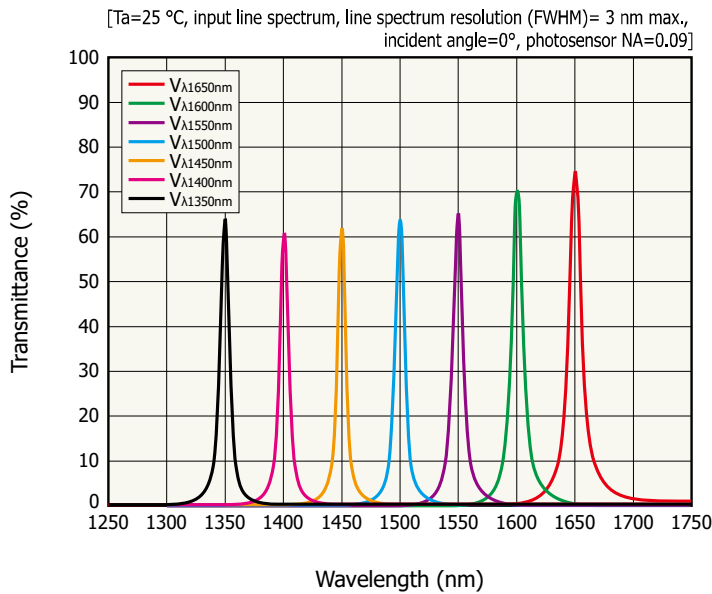

KACCB0477EA

(b) C13272-02/-03

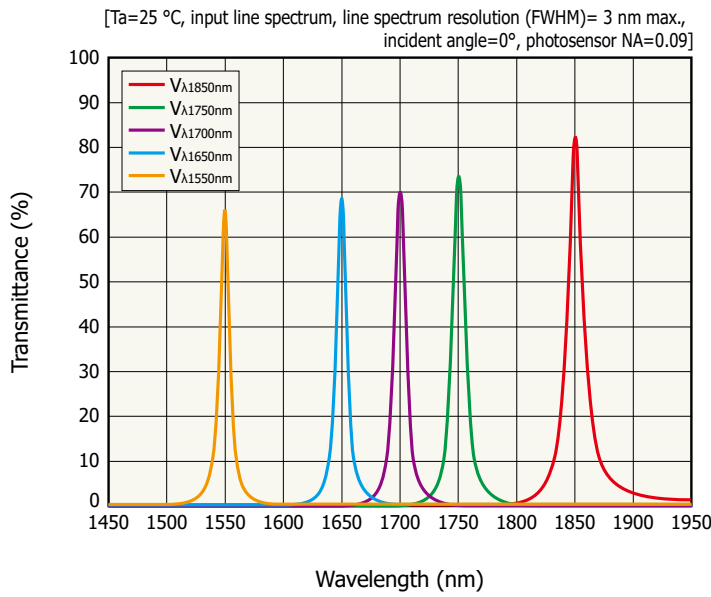

KACCB0405EA

(c) C14273

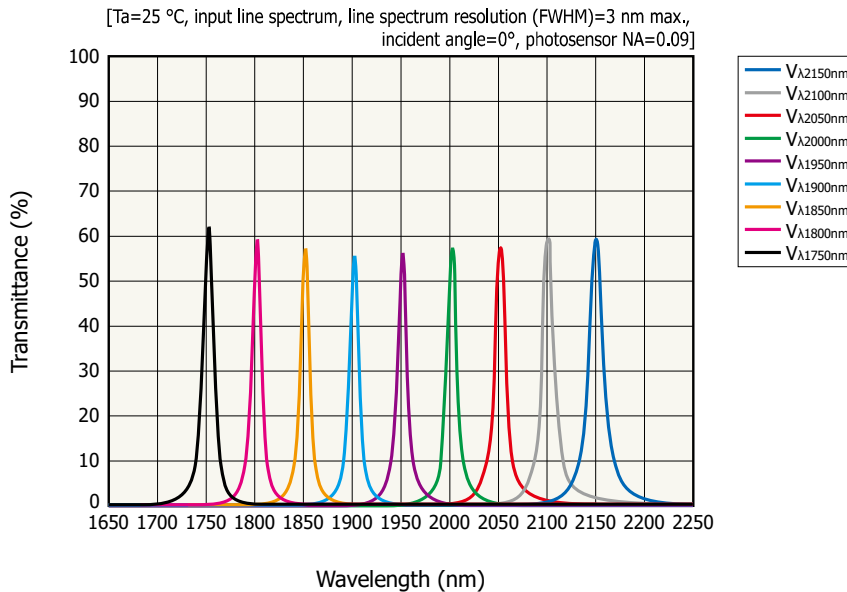

KACCB0508EA

Incident light aperture angle

Incident light aperture angle should affect the characteristics of a MEMS-FPI spectrum sensor. Figure 2-20 shows how peak transmission wavelengths are affected by the incident light aperture angle, and the how it influences wavelength resolution is indicated in Figure 2-21. As the angle of aperture is widened, the peak transmission wavelengths are shifted to a shorter wavelength side, and the wavelength resolution becomes coarser. Therefore, the incident light aperture angle should be made as small as possible (photosensor NA≤0.09, recommended), and also input to the MEMS-FPI spectrum sensor should be as vertically as possible (incident angle=0°). The conditions of photosensor NA=0.09 and incident angle=0° are set on the pre-shipping test of the MEMS-FPI spectrum sensors.

[Figure 2-20] Peak transmission wavelength vs. photosensor NA, incident light aperture angle (typical example)
 (a) C14272

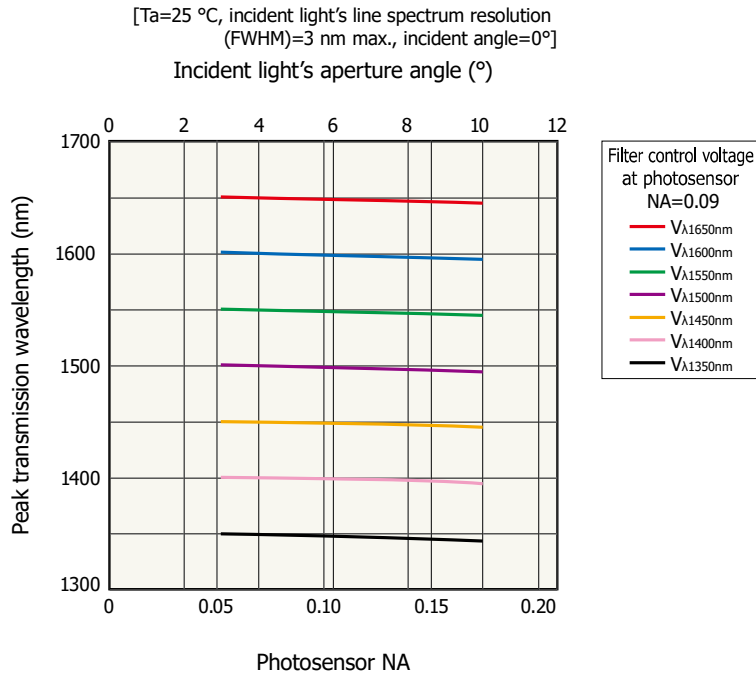

KACCB0489EA

(b) C13272-02/-03

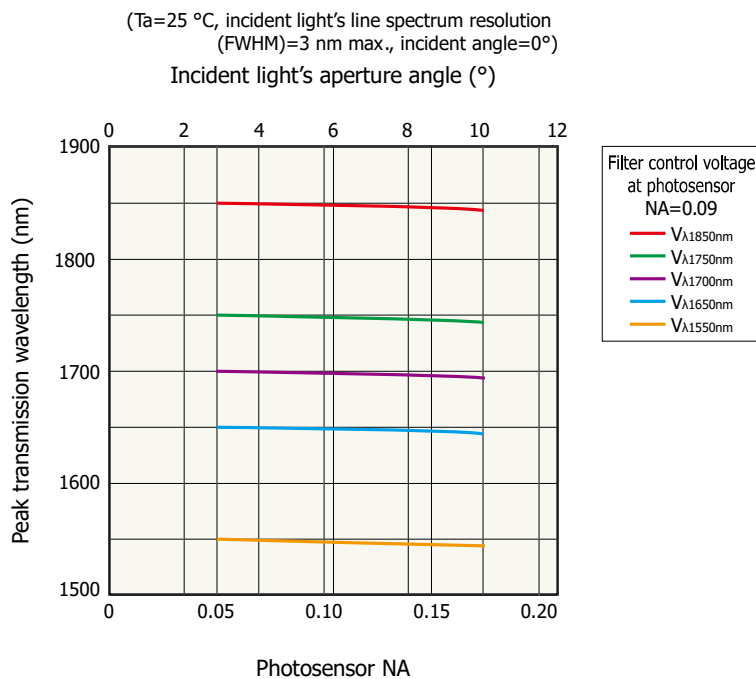

KACCB0447EC

(c) C14273

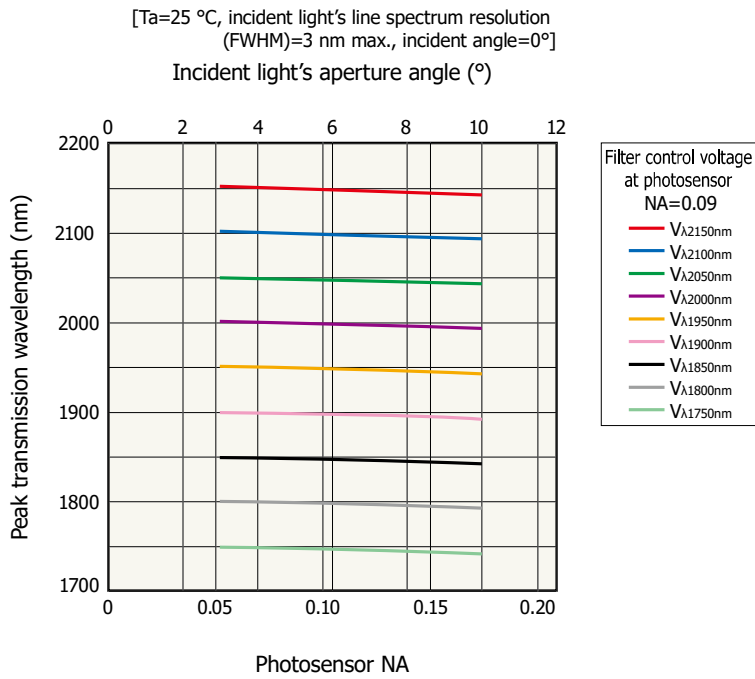

KACCB0525EA

[Figure 2-21] Spectral resolution vs. photosensor NA, incident light aperture angle (typical example)
(a) C14272

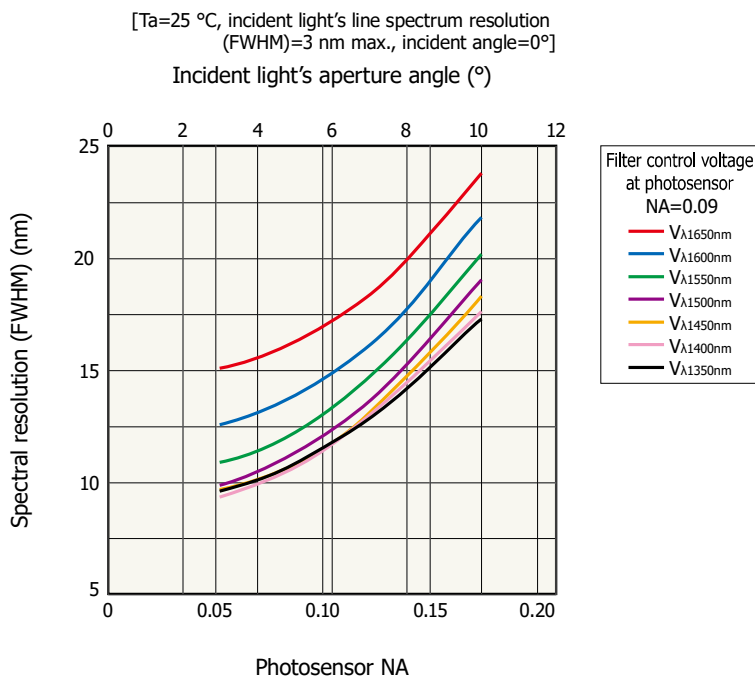

KACCB0490EA

(b) C13272-02/-03

[Ta=25 °C, incident light's line spectrum resolution (FWHM)=3 nm max., incident angle=0°]
Incident light's aperture angle (°)

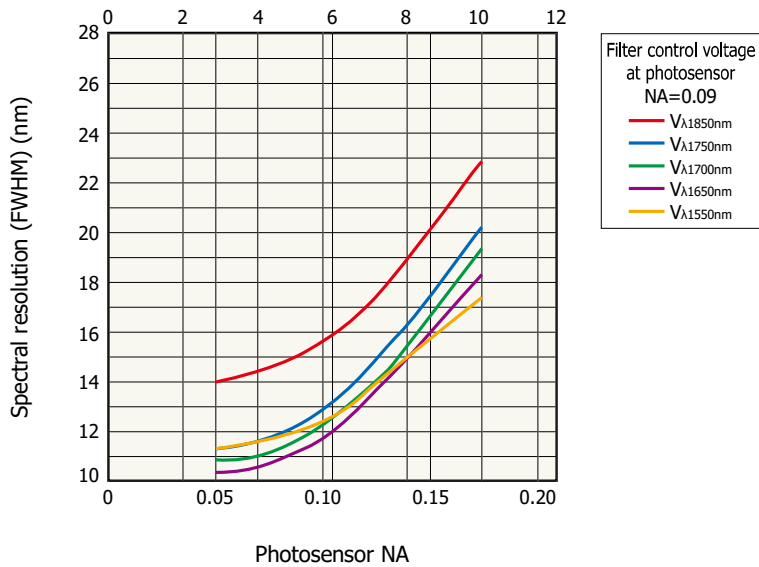

KACCB0448EC

(c) C14273

[Ta=25 °C, incident light's line spectrum resolution (FWHM)=3 nm max., incident angle=0°]
Incident light's aperture angle (°)

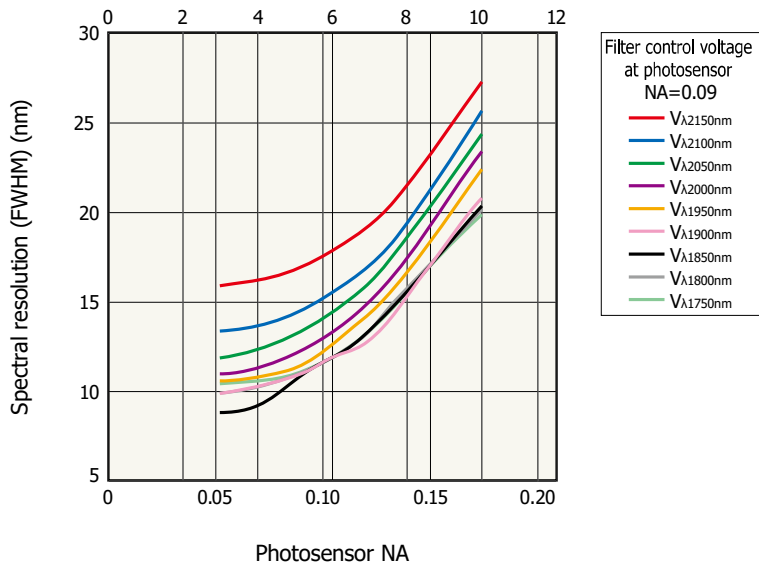

KACCB0526EA

InGaAs PIN photodiodes

MEMS-FPI spectrum sensors have a Hamamatsu InGaAs PIN photodiode built in as a photosensor. Figure 2-22 shows the spectral response characteristics of the built-in InGaAs PIN photodiode.

[Figure 2-22] Spectral response of built-in InGaAs PIN photodiode (typical example)

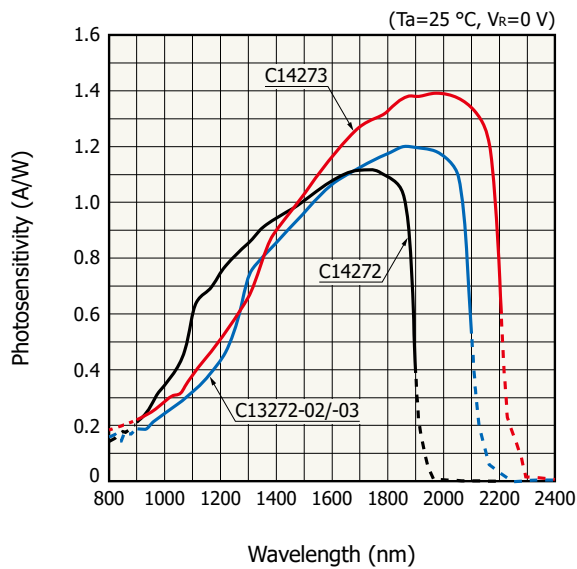

KIRDB0634EE

2-3 How to use

Connection example

An example of connection to a MEMS-FPI spectrum sensor is shown in Figure 2-23, and that of equipment used there is in Table 4-1.

[Figure 2-23] Connection example

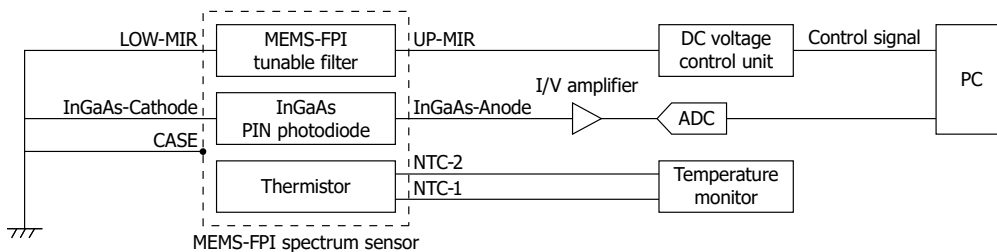

KACCC0804EA

[Table 2-4] Equipment example used in connection example [Figure 2-23]

Equipment	Type no.	Manufacturer
DC voltage control unit*	6156	ADC Corporation
I/V amplifier	C4159-03	Hamamatsu Photonics

* Two units in series connection

Evaluation circuit

The C13294-02 is a circuit board designed to simply evaluate the MEMS-FPI spectral sensor. By connecting the circuit board to a PC (sold separately) with a USB cable (A-micro B type) and using the accompanying evaluation software, you can evaluate the characteristics of the MEMS-FPI spectrum sensor.

[Figure 2-24] Block diagram (C13294-02)

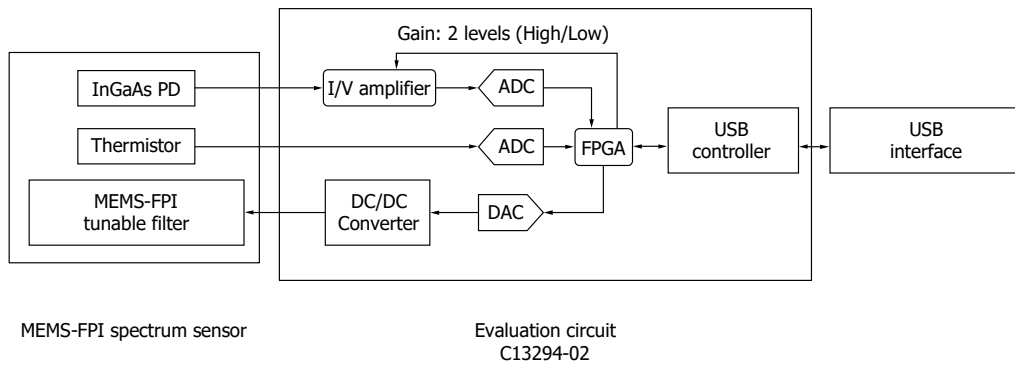

KACCC0845EB

The procedure for using the evaluation circuit C13294-02 should be referred to "4. Q&A | [Q10](#)."

Example of evaluation system

• On use of monochromator

An example of MEMS-FPI spectrum sensor evaluation system is shown in Figure 2-25. White light emitted by a halogen lamp, etc. is converted into single wavelength light by a monochromator, which is guided to a lens through an optical fiber, and then illuminated to the MEMS-FPI spectrum sensor. Signal from the sensor is outputted via an amplifier. A wavelength profile at a fixed air gap can be obtained by scanning the monochromator's wavelengths with fixing the MEMS-FPI spectrum sensor's filter control voltage. Subsequently, plural spectrums can be obtained by acquiring the data in the same way with varying the filter control voltage.

[Figure 2-25] Example of evaluation system (monochromatic light from monochromator)

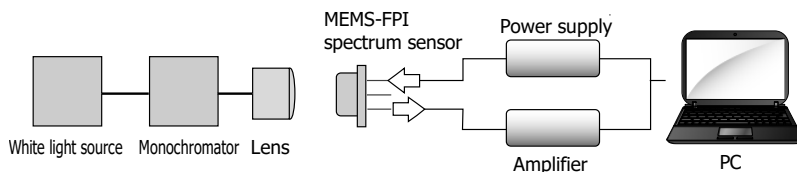

KACCC0846EA

An example of MEMS-FPI spectrum sensor C13272-03 evaluation result is shown in Figure 2-26. A wavelength profile at each filter control voltage is defined by the maximum value of output at $V_{\lambda 1550\text{nm}}$. The output value is related to the measurement system, the transmittance characteristics of the MEMS-FPI tunable filter, and the spectral response characteristics of the photosensor.

Wavelength resolution can be calculated by estimating FWHM (full width half maximum) with Gauss fitting the wavelength profile. As shown in Figure 2-7, the wavelength resolution over a spectral response range (1550 to 1850 nm) is 20 nm or smaller.

[Figure 2-26] Wavelength profile (C13272-03, typical example)

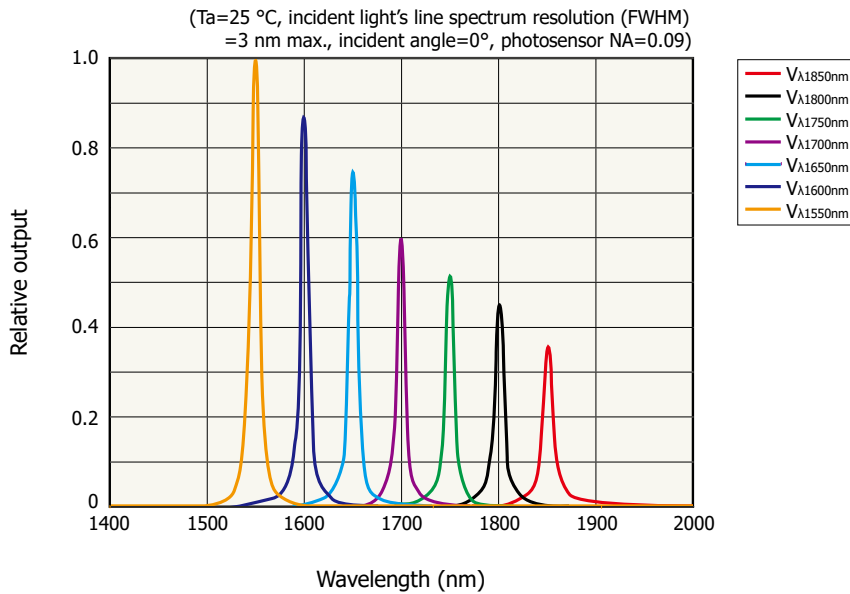

KACCB0449EA

• On no use of monochromator

A system for evaluating a MEMS-FPI spectrum sensor can be formed even without using a monochromator.

[Figure 2-27] Example of evaluation system (white light source)

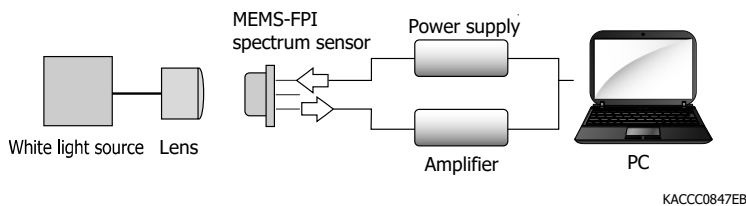

Applications

A setup example of an absorbance measurement with using the MEMS-FPI spectrum sensor is shown in Figure 2-28. Transmission light intensity (I) at a single wavelength in particular is to be obtained by illuminating light transmitted through a measurement cell to a MEMS-FPI spectrum sensor. Assuming no sample in the measurement cell to be reference (intensity I_0), an approximate value of the absorbance (A) at a single wavelength can be estimated by equation (2-21).

$$A = -\log_{10} \left(\frac{I}{I_0} \right) \cdots (2-21)$$

[Figure 2-28] Absorbance measurement setup example using MEMS-FPI spectrum sensor

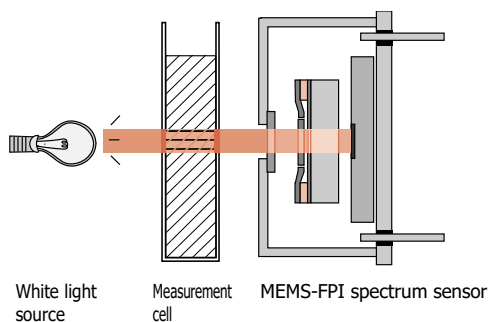

The MEMS-FPI spectrum sensor is very compact, which is expected to be built in a small device or connected with

a mobile terminal. An image of use in a compact module with a smart phone is shown in Figure 2-29.

[Figure 2-29] Image of use in compact module

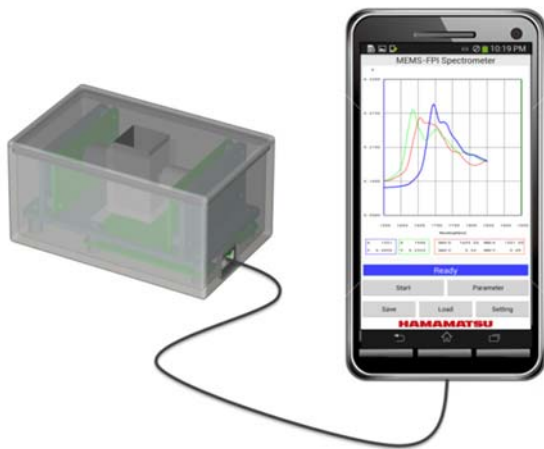

3. Spectroscopic modules

This compact module has a built-in light source, control circuit, and MEMS-FPI spectrum sensor consisting of an InGaAs PIN photodiode and MEMS-FPI tunable filter which can vary its transmission wavelength by changing the applied voltage. Spectrum and absorbance can be measured by connecting a PC via USB. Peak transmission wavelength shift due to the ambient temperature change is corrected with the control circuit. The product includes evaluation software with functions for setting measurement conditions, acquiring and saving data, drawing graphs, and so on. Furthermore, the dynamic link library (DLL) function specifications are disclosed, so users can create their original measurement software programs.

3-1 Control circuit

Figure 3-1 shows a block diagram of the spectroscopic module. The control circuit controls voltage applied to the MEMS-FPI tunable filter. This circuit converts analog output from the InGaAs PIN photodiode in the sensor into a digital signal using a 16-bit A/D converter. It also reads thermistor resistance value and performs feedback control to suppress the peak transmission wavelength shift depending on temperature. The external interface contains a microcontroller and the module can be connected to a PC via a USB cable.

We offer customization for the UART interface (when there is a large quantity). Contact us for detailed information.

[Figure 3-1] Block diagram

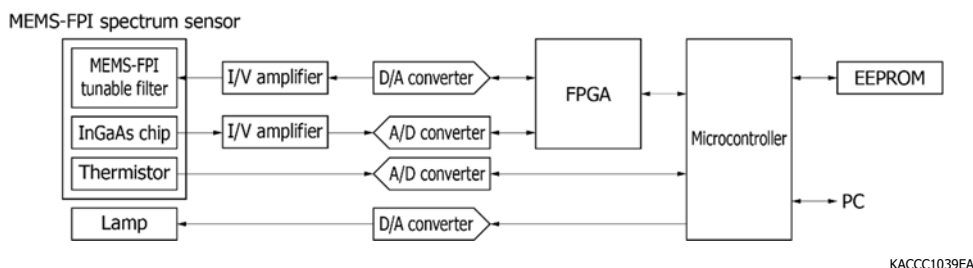

3-2 Evaluation software

Using the evaluation software supplied with the spectroscopic module, you can control the spectroscopic module, as well as acquire and save measurement data from a PC connected to the module via USB.

By installing the evaluation software into a PC, you can perform the following basic operations.

- Acquire and save measurement data
- Set measurement conditions

- Set built-in lamp
- Acquire module information (type number, serial number, spectral response range, etc.)
- Display graphs
- Arithmetic functions
 - Comparison with the reference data (reflectance, absorbance, etc.)

Up to 8 spectroscopic modules can be connected to a single PC for use.
Compatible OS: Microsoft Windows 10 (32-bit, 64-bit)

[Figure 3-2] Display example of evaluation software

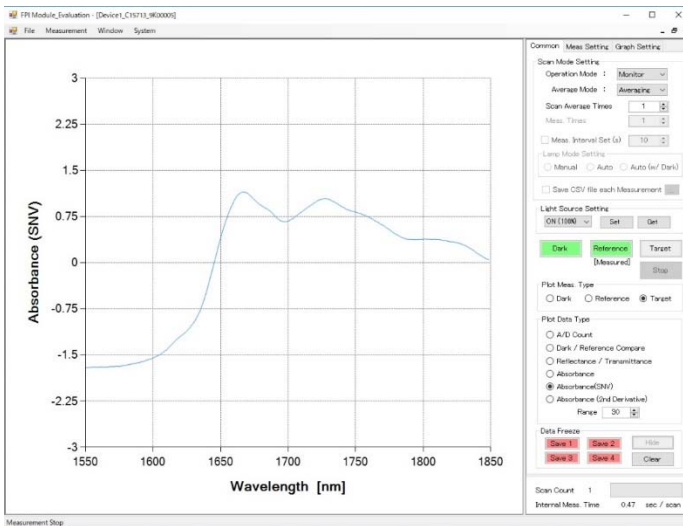

The CD-ROM included in the spectroscopic module contains evaluation software, DLL, and sample software. The evaluation software uses the DLL to control the spectroscopic module. Because the evaluation software cannot directly access I/O and memory, it calls necessary functions from the DLL to control the spectroscopic module, via the device driver and USB interface. Furthermore, using the DLL, users can develop their own original software. The function specifications and software instruction manual are on the CD-ROM.

[Figure 3-3] Software configuration

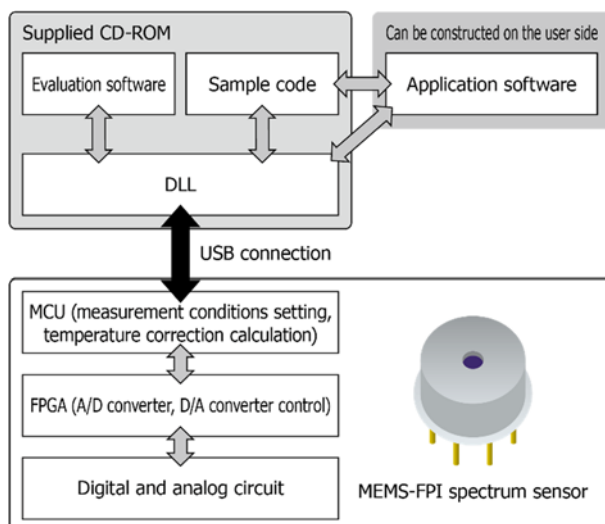

KACCC1040EA

3-3 Optical fiber adapter (sold separately)

An adapter [Figure 3-4] is available for easily coupling an optical fiber with an SMA connector to the spectroscopic

module. Fix it to the spectroscopic module using the screws (included). Do not use the built-in lamp. Instead, use this when coupling the sensor and optical fiber (such as when doing transmitted light measurement). An optical fiber and optical components such as a condenser lens are not installed in the optical fiber adapter.

[Figure 3-4] Optical fiber adapter A15719



3-4 Characteristics

A peak transmission wavelength of a MEMS-FPI spectrum sensor has temperature dependence (see "2-2 Characteristics | Temperature characteristics"). Figure 2-11 shows the relationship between the ambient temperature around the MEMS-FPI spectrum sensor and the peak transmission wavelength, when no correction is made for the effect of temperature change. In contrast, Figure 3-5 shows the relationship between the ambient temperature and the peak transmission wavelength of this module, where the influence of temperature change has been corrected.

The control circuit in this module does feedback control to voltage applied to the MEMS-FPI tunable filter in response to changes in ambient temperature (operating temperature range), suppressing peak transmission wavelength shift. The wavelength temperature dependence in center wavelength (C15712: $\lambda=1500$ nm, C15713: $\lambda=1700$ nm, C15714 : $\lambda=1950$ nm) is ± 0.1 nm/ $^{\circ}$ C or lower.

[Figure 3-5] Peak transmission wavelength vs. ambient temperature (typical example)

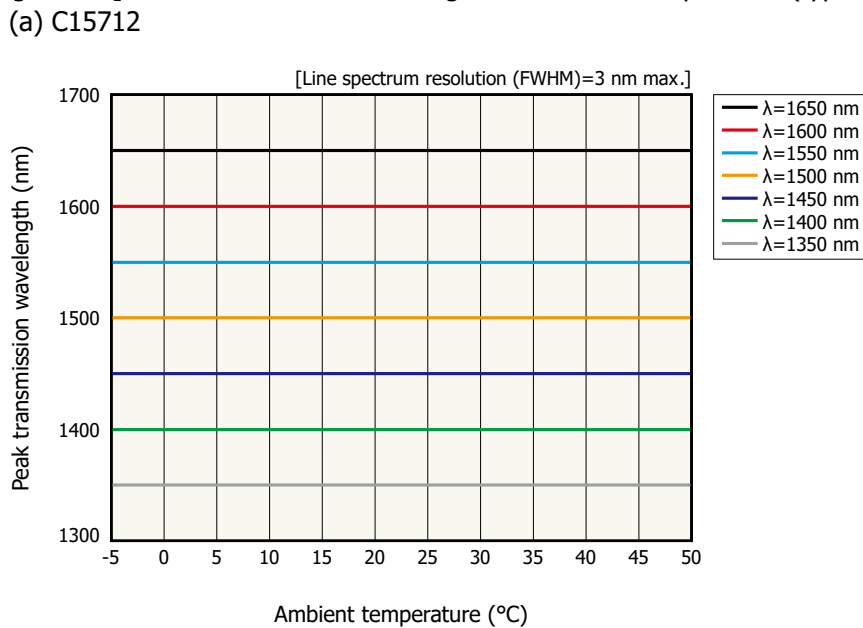

KACCB0633EA

(b) C15713

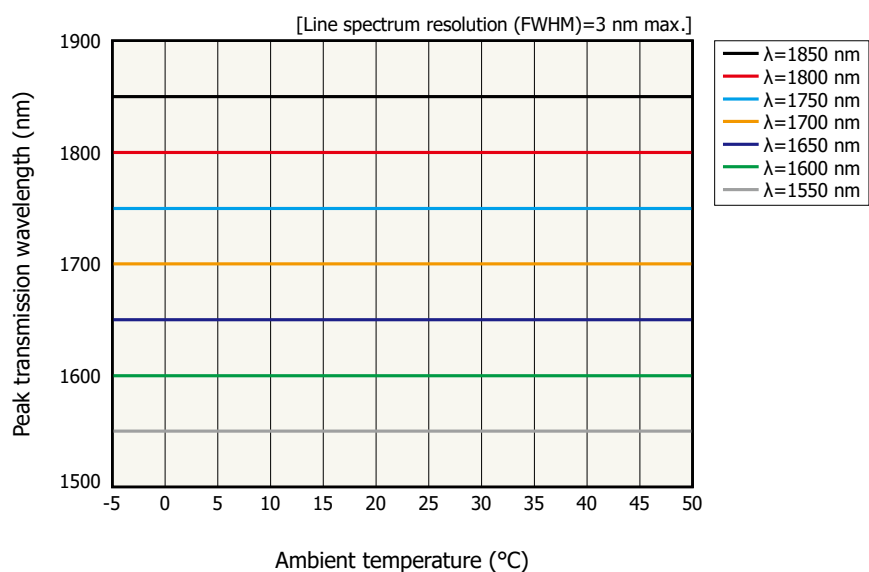

(c) C15714

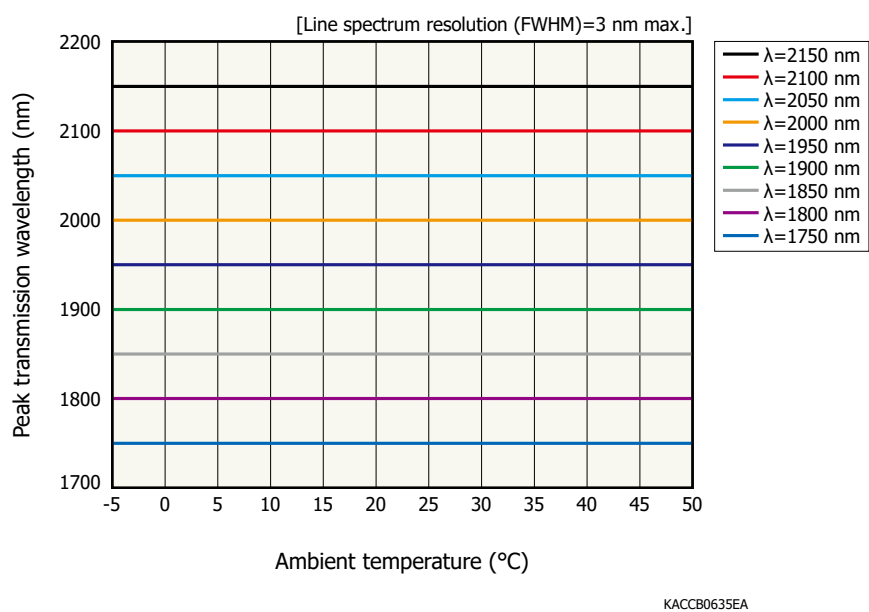

Temperature dependence of the spectral resolution (FWHM) is shown in Figure 3-6. The spectral resolution is almost constant even when the temperature changes.

[Figure 3-6] Spectral resolution vs. ambient temperature (typical example)

(a) C15712

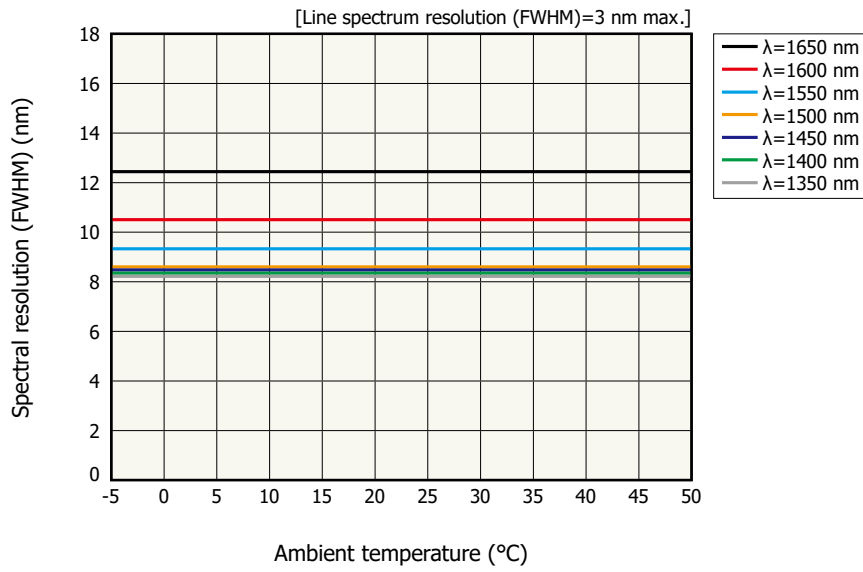

KACCB0636EA

(b) C15713

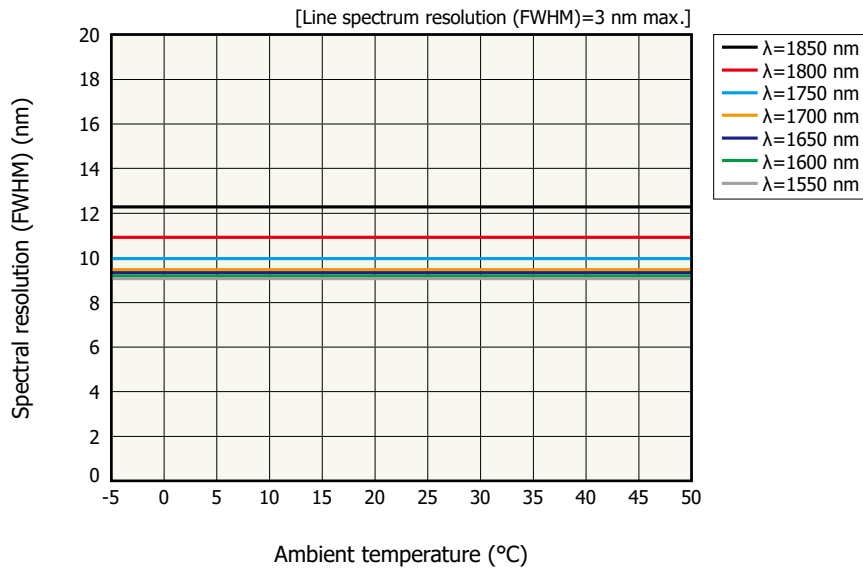

KACCB0637EA

(c) C15714

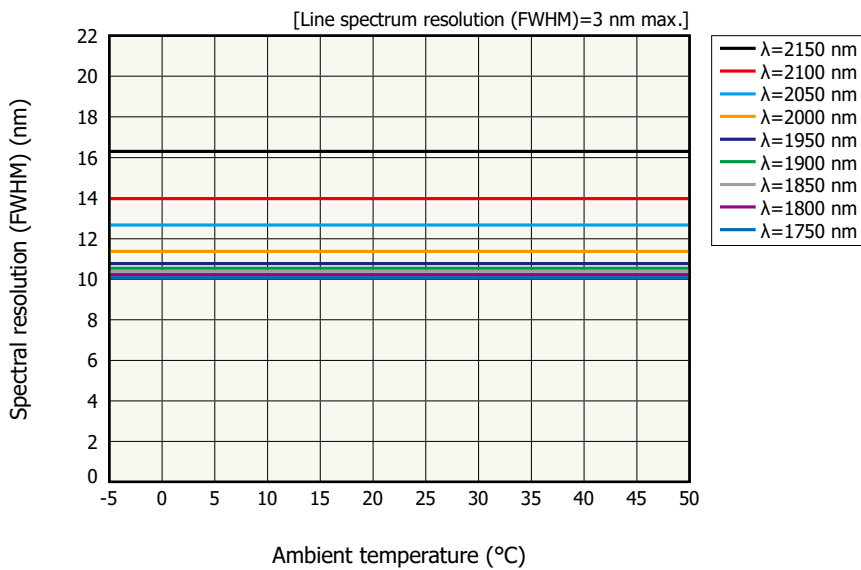

KACCB0638EA

3-5 Measurement example

With near-infrared spectrophotometry, absorbance is converted from the measured optical spectrum, then data analysis is done using methods such as standard normal variate (SNV) and secondary differentiation.

Reflected light measurement

You can measure reflected light using the lamp built into this module. Figure 3-7 shows a measurement example.

[Figure 3-7] Example of reflected light measurement

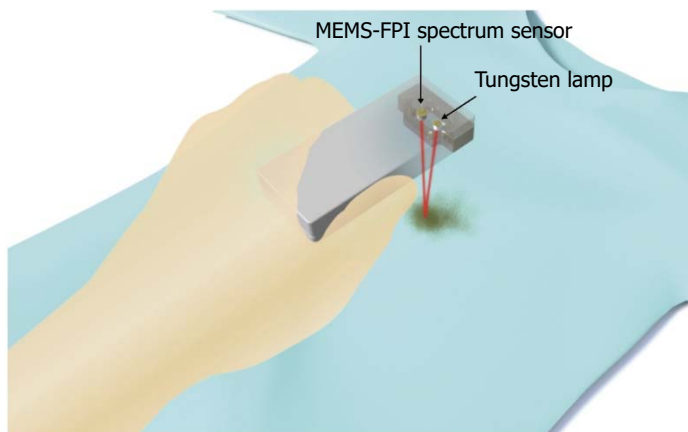

Measurement examples of textile/plastic absorbance are shown in figures 3-8 and 3-9. In the near infrared region, different spectra are seen depending on the material, so it is possible to identify materials.

[Figure 3-8] Absorbance spectra of textile (measurement example)

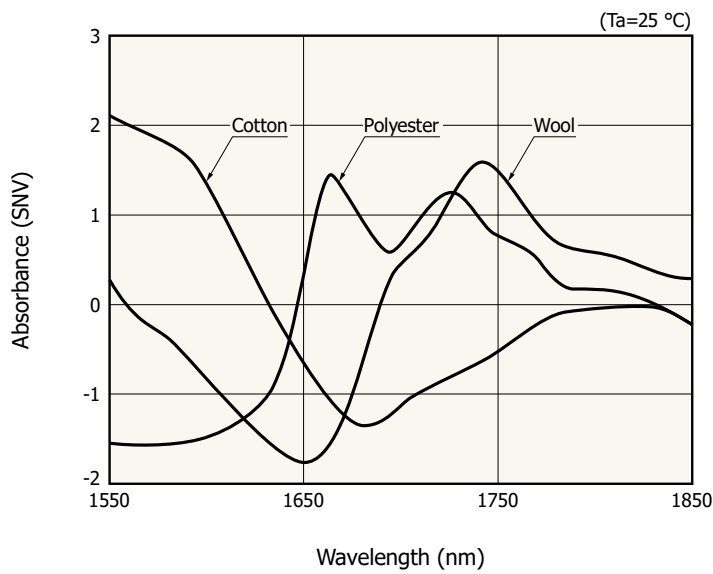

KACCB0628EA

[Figure 3-9] Absorbance spectra of plastic (measurement example)

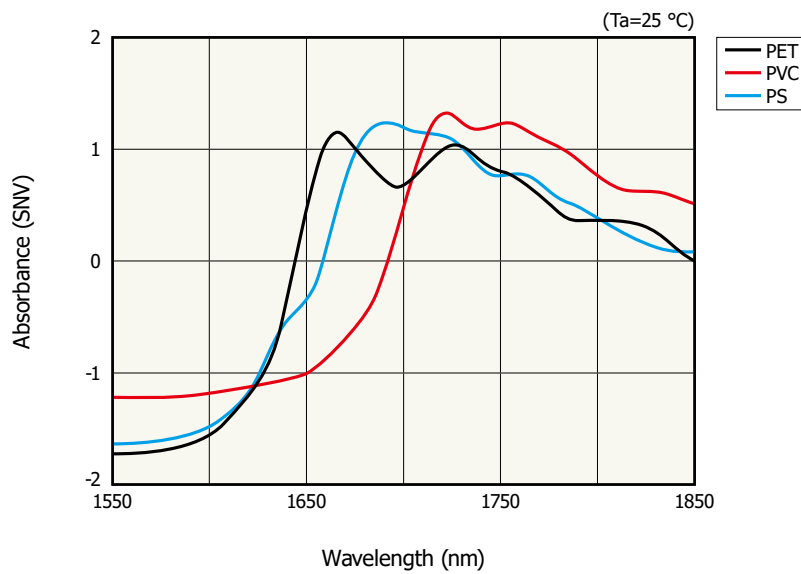

KACCB0639EA

Transmitted light measurement

Figure 3-10 shows the measurement system of spectra for transmitted light. The light source built into this module is not used at this point. The light source must be prepared separately.

[Figure 3-10] Measurement system of transmitted light measurement

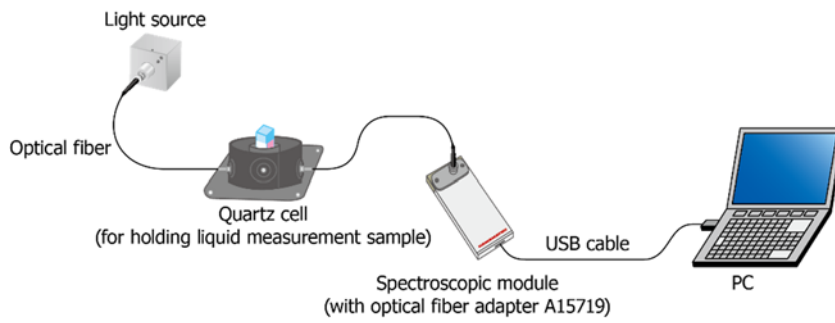

KACCC1034EA

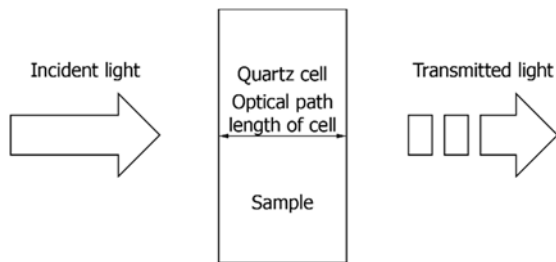

KACCC1023EA

Figure 3-11 shows an absorbance measurement example of pure water. It has detected absorption by OH groups with peaks around 1450 nm and 1940 nm. Ethanol [Figure 3-12] has absorbance spectra different from pure water, such as around 1700 nm.

[Figure 3-11] Pure water absorbance spectra (measurement example)

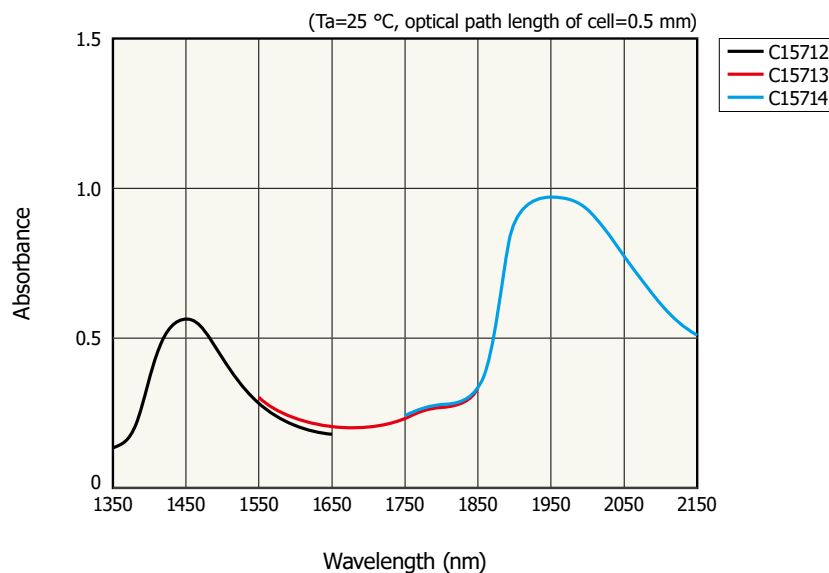

KACCB0640EA

[Figure 3-12] Ethanol absorbance spectra (measurement example)

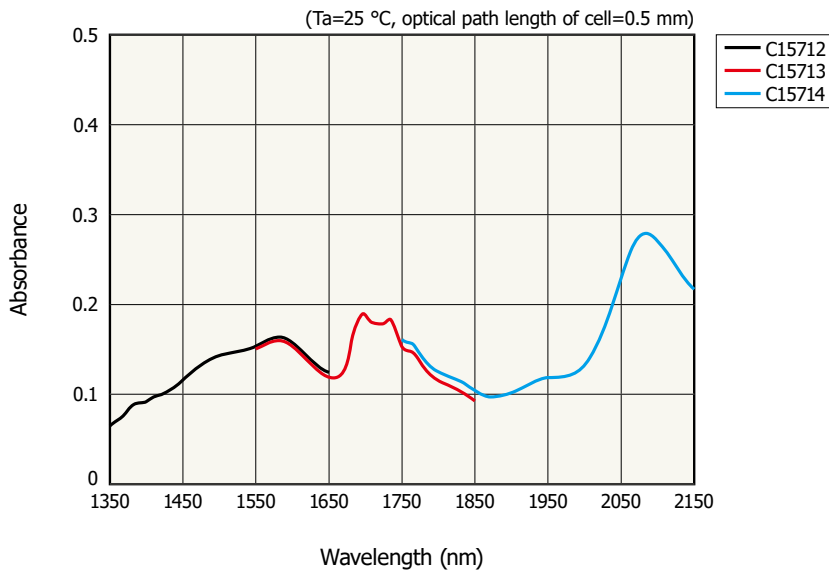

KACCB0641EA

4. Q&A

Q1 What is the difference between a spectroscopic module and an FTIR engine?

Table 4-1 shows the comparison between the spectroscopic module and the FTIR engine. The spectroscopic module is a compact, low-cost module with built-in MEMS-FPI spectrum sensor, light source, and control circuit. The FTIR engine has a wide spectral response range and offers excellent spectral resolution.

The MEMS-FPI spectrum sensor has a simple structure using a single-element photodiode. It has the advantage of a compact package that is easy to incorporate into a detection device.

[Table 4-1] Comparison between spectroscopic module and FTIR engine

Parameter	Spectroscopic module			FTIR engine
	C15712	C15713	C15714	C15511-01
Type no.	C14272	C13272-03	C14273	-
Built-in sensor	C14272	C13272-03	C14273	-
Spectral response range	1.35 to 1.65 μm	1.55 to 1.85 μm	1.75 to 2.15 μm	1.1 to 2.5 μm
Spectral resolution (FWHM) max.	18 nm	20 nm	22 nm	8 nm
Compact size		◎		○
Low cost		◎		○

Q2 Does the spectral resolution of the MEMS-FPI spectrum sensor vary with the transmission wavelength ?

Yes, the spectral resolution varies with the transmission wavelength. A typical example is shown in the Figure 3-3.

Q3 Are there any particular cautions needed to prevent a MEMS-FPI tunable filter from damage?

Be sure to keep the filter control voltage from exceeding the absolute maximum rating. If this value is exceeded, the MEMS-FPI tunable filter will break. Note that the absolute maximum rating of the filter control voltage varies by product and change depending on the temperature.

As a typical example, the temperature characteristics of $V_{\lambda 1550\text{nm}}$ (filter control voltage for transmitting light with $\lambda=1550\text{ nm}$) on the C13272-03 are shown in Figure 4-1. The absolute maximum rating of the C13272-03 filter control voltage is $V_{\lambda 1550\text{nm}} + 0.5\text{ V}$. This indicates that adding 0.5 V or more to $V_{\lambda 1550\text{nm}}$ at a given temperature may damage the MEMS-FPI tunable filter.

[Figure 4-1] Temperature characteristics of $V_{\lambda 1550\text{nm}}$ (C13272-03, typical example)

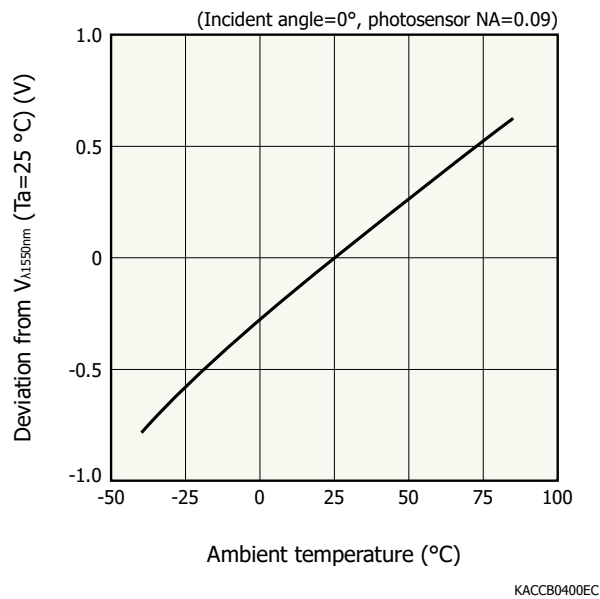

Use of the software attached with the evaluation circuit C13294-02 should relieve such a risk. The sensor calibration coefficient attached with a sensor should be inputted on the software. It is noted that the sensor calibration coefficient provided are from our measurement at room temperature ($T_a=25\text{ °C}$). Due countermeasures against electrostatic discharge should be taken by referring to the operational manual as a photodiode built in the MEMS-FPI spectrum sensor is very weak to the static electricity. The details about electrostatic discharge resistance should be referred to datasheets or an operational manual.

When using the spectroscopic module, the control circuit automatically adjusts the filter control voltage of the MEMS-FPI tunable filter according to changes in ambient temperature, so there is no risk of filter damage.

Q4 How does the ambient temperature affect the MEMS-FPI spectrum sensor's characteristics?

The MEMS-FPI spectrum sensor has a temperature characteristic, so there is a characteristic change with the temperature. An example of the C13272 series temperature characteristic is shown in the Figure 2-11 and 2-14. It is possible to compensate the temperature using a calculation formula (2-2 Characteristics | Filter control voltage and peak transmission wavelength | Compensation of temperature characteristics of filter control voltage and peak transmission wavelength). Due compensation should be done by a user as necessary for improving the measurement accuracy.

When using the spectroscopic module, the control circuit can do correction for influence of changes in ambient temperature.

Q5 What is a relation between MEMS-FPI tunable filter's transmission wavelength and filter control voltage?

High reflection upper and lower mirrors of the MEMS-FPI tunable filter are faced each other via an air gap, and the transmission wavelength is to be varied by tuning the gap with the filter control voltage. The transmission wavelength gets shorter by narrowing the air gap with filter control voltage increase. There are some individual differences on the mirrors and the air gap, so a relation between the peak transmission wavelength and the filter control voltage differs from unit to unit. Therefore, the inspection data showing the filter control voltages ($T_a=25\text{ °C}$) for the minimum and maximum values within the spectral response range is to be attached with a product to deliver. The reference data of four constants (sensor calibration coefficient) for calculating the relationship between the transmission wavelength and the filter control voltage is also to be added. It is noted these data provided are from our own measurement conditions, so no guarantee on a user's operating environments (optical environments, temperature, etc.) are given. For enhancing the measurement accuracy, calibration on a user's own operating conditions may be required. Furthermore, the filter control voltage has to be tuned at the absolute maximum rating or less.

Q6 What should be prepared for evaluating the MEMS-FPI spectrum sensor?

The evaluation circuit C13294-02 (sold separately) is to be prepared for evaluating the MEMS-FPI spectrum sensor. In addition, a light source (e.g., a white light source like halogen) should be prepared.

The MEMS-FPI spectrum sensor can be easily evaluated using spectroscopic modules C15712, C15713, and C15714 (sold separately) which have a built-in MEMS-FPI spectrum sensor, tungsten lamp, and control circuit.

Q7 Could you suggest a suitable light source?

A suitable light source should differ with measurement methods (e.g., reflection, transmission), measurement objects, etc. In general, a white light source like halogen is suggested. A near infrared LED (L10660 series by Hamamatsu, 1450 nm in peak emission wavelength, 120 nm in FWHM, L12509 series, 1550 nm in peak emission wavelength, 120 nm in FWHM, or L13895 series, 1450 nm in peak emission wavelength, 120 nm in FWHM) may be appropriate on some applications. However, near infrared LEDs cannot emit light over the entire spectral response range of the MEMS-FPI spectrum sensor.

Q8 How can measurement time be shortened?

We recommend that you evaluate the spectroscopic module first in order to achieve high-speed operation. The default single measurement time of the spectroscopic module is approximately 0.4 s with the C15712 and C15713 (when measuring 300 nm width in 1 nm steps) and approximately 0.6 s with the C15714 (when measuring 400 nm width in 1 nm steps). (This excludes time required to calculate and display graph data, because it depends on PC performance.)

Measurement time can be made even shorter by reducing the point average times. In that case noise may increase, so settings must be changed appropriately.

3 to 12 seconds are total measurement time on default when the MEMS-FPI spectrum sensor is operated with the evaluation circuit C13294-02 (sold separately) in general.

Note: Default settings of the evaluation software of spectroscopic modules

- Min. Wavelength (nm): lower limit of spectral response range
- Max. Wavelength (nm): upper limit of spectral response range
- Step (nm) : 1
- Point Average Times: 128
- Meas. Interval (μ s): 2.5

Q9 Can the evaluation circuit C13294-02 realize selective measurement by arbitrary wavelength points?

The spectroscopic modules C15712, C15713, C15714 can perform measurement with up to 10 wavelength points specified.

The evaluation circuit C13294-02 does not have such a function.

The following shows reference examples of the response speed (when using the C13272-02) on conducting a step operation by varying the filter control voltage, for the purpose of circuit and software design for MEMS-FPI spectrum sensor.

<Reference values>

1 step for 300 nm range (e.g., 1550 nm to 1850 nm)

→ 1 ms typ. in settling time (99%)

4 steps for 5 nm range (e.g., 1550 nm to 1555 nm, 1645 nm to 1650 nm, 1745 nm to 1750 nm, 1845 nm to 1850 nm)

→ 0.2 ms typ. in settling time (99%) at each step

The settling time must also be considered when using other MEMS-FPI spectrum sensors. The measurement time on an actual use greatly depends upon the circuit and the software to be designed by a user.

Q10 How can the evaluation circuit C13294-02 be operated?

The flow of a measurement using the evaluation circuit C13294-02 (software attached) is herein explained.

① Dark measurement

The dark data from a MEMS-FPI spectrum sensor in a dark state with a specified wavelength range is to be acquired (incidence of the light to a sensor should be interrupted). This dark data is to be subtracted from the sample measurement data at a later step.

[Figure 4-2] Dark measurement

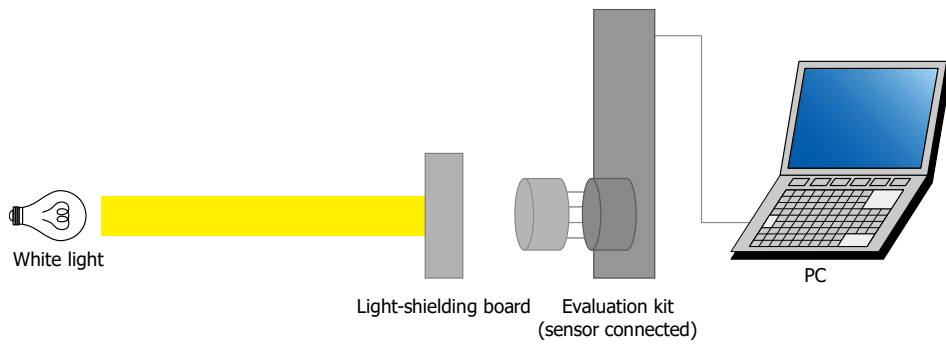

KACCC0826EB

② Reference measurement

The reference data from a MEMS-FPI spectrum sensor with light input within a specified wavelength range is to be acquired.

[Figure 4-3] Reference measurement

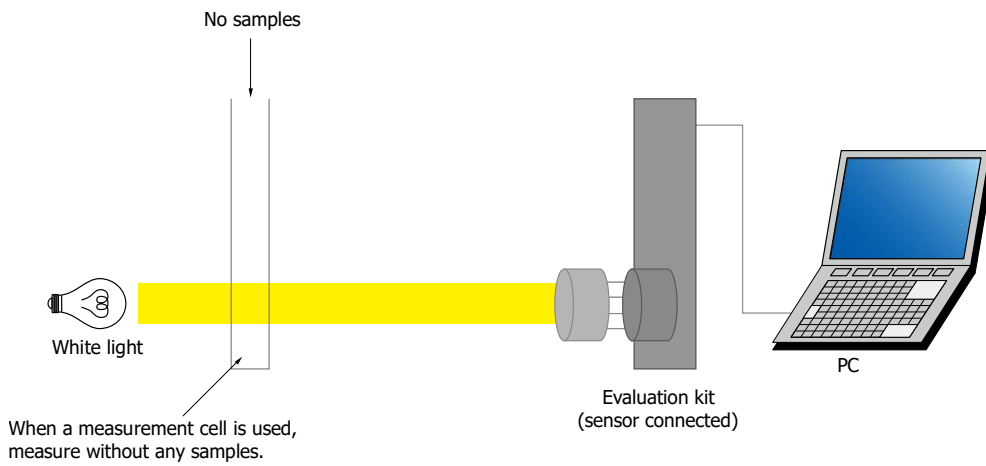

KACCC0827EB

③ Sample measurement

The sample data from a MEMS-FPI spectrum sensor while a sample is placed between a light source and the sensor within a specified wavelength range is to be acquired. On a multi-sample measurement, the sample measurement is to be repeated in the same way for the number of settings.

[Figure 4-4] Sample measurement

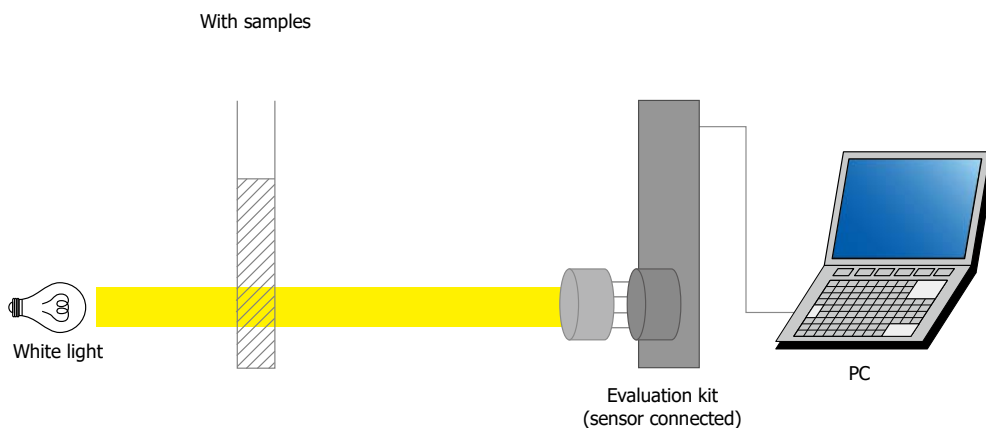

KACCC0828EB

④Graph output

The output of transmission or absorbance can be obtained by a graph [A/D counts (PD output amplified by an amp) being possible to obtain], and the acquired data can be stored in the CSV format.

Q11 Is DLL for the spectroscopic modules C15712, C15713, C15714 and the evaluation circuit C13294-02 available?

The DLL is available for spectroscopic modules, so users can create their original software programs. For the evaluation circuit C13294-02, DLL is not available because it is not intended to be incorporated into a measuring system.

Q12 Do you have a plan to develop a large-area MEMS-FPI spectrum sensor?

We have no plan at this point. There are two types of the MEMS-FPI tunable filter, and each feature is summarized in Table 4-2. We are focusing on the advantages (low cost and low voltage operation) of an electro-static type, and are planning to develop a new product by utilizing these features.

[Table 4-2] Comparison between electro-static actuator and piezo-actuator methods (MEMS-FPI tunable filter)

Parameter	Electro-static actuator (Hamamatsu Photonics K.K.)	Piezo-actuator
Advantage	Low cost, low voltage operation	Suitable for large size
Disadvantage	Difficult for large size	High cost, high voltage operation

Q13 Is it possible to manage the serial numbers with 2D codes when the MEMS-FPI spectrum sensor is used in mass-production equipment?

DataMatrix (2D code), the type number, the serial number and the lot number are to be marked on a top surface of a metal package, and the DataMatrix includes information on the type number and the serial number, so it should be utilized. The details about the marking information should be referred to the datasheet or the operational manual.

Q14 Is it possible to make a custom product to cover a new spectral response range?

We would like you to use the standard product as much as possible. If the wavelength ranges of our current lineup cannot cover your wishes, please consult with the Hamamatsu office. Customization is to be considered by learning the requirements (wavelength range, application, expected business scale, etc).

Q15 Can the spectral response range be widened by about 300 to 400 nm?

The MEMS-FPI tunable filter uses the principle of a Fabry-Perot interferometer and cannot theoretically extend the spectral response range. When the air gap between the upper and lower mirrors is $m\lambda/2$, the n-th order light component relative to the detection wavelength also passes through the MEMS-FPI tunable filter, since it functions as a filter that transmits approximately the wavelength λ (m : integer). The n-th order light component is blocked from the outside of the package by the built-in band-pass filter.

Q16 Are there any demo units (MEMS-FPI spectrum sensors or spectroscopic modules) available? The basic characteristics are needed to see before purchase.

Yes, a few demo units have been prepared, so consult with our sales representative, please.

Q17 What are the contents of the final inspection sheet and reference datasheet attached to the MEMS-FPI spectrum sensor and what kind of data format are they in?

The final inspection sheet contains the following inspection items.

[C14272]

- Peak voltage ($\lambda=1650$ nm)
- Peak voltage ($\lambda=1350$ nm)
- Dark current ($V_R=0.5$ V)
- Thermistor resistance

[C13272-02/-03]

- Peak voltage ($\lambda=1850$ nm)
- Peak voltage ($\lambda=1550$ nm)
- Dark current ($V_R=0.5$ V)

- Thermistor resistance

[C14273]

- Peak voltage ($\lambda=2150$ nm)
- Peak voltage ($\lambda=1750$ nm)
- Dark current ($V_R=0.5$ V)
- Thermistor resistance

Measurement conditions are as follows: incident angle: 0°, photosensor NA: 0.09, incident light's line spectrum resolution (FWHM): 3 nm max., ambient temperature: 25 °C. The final inspection sheet is attached to the product as a paper document.

The reference datasheet contains the room temperature compensation constant and the temperature compensation constant (see "2-2 Characteristics | Filter control voltage and peak transmission wavelength") under the above measurement conditions for each serial number. A CD containing the reference datasheet (Microsoft Excel data) is attached to the product.

Q18 There are three different wavelength band types for the spectroscopic modules. Can I buy one and replace the MEMS-FPI spectrum sensor with another type of sensor?

You cannot replace the MEMS-FPI spectrum sensor in the spectroscopic module. You must purchase a spectroscopic module with the required wavelength band.

Q19 What is the service life of the lamp built in spectroscopic module?

The estimated service life of the lamp is approximately 40000 hours. The service life varies depending on the use conditions.

Q20 What is the S/N of the spectroscopic module?

With ambient temperature: 25 °C, gain setting: middle (initial setting), S/N=10000 typ. (about the same for C15712, C15713, C15714).

S/N is given by equation (4-1).

$S/N = (\text{Count value when incident light is 75\% of maximum range} - \text{Dark average value}) / \text{Dark standard deviation}$
 ... (4-1)

In order to reduce the noise component, increase the point average times (this will increase measurement time).
 In order to further reduce the noise component, increase the scan average times.

• Initial setting

Min. Wavelength (nm): lower limit of spectral response range

Max. Wavelength (nm): upper limit of spectral response range

Step (nm): 1

Point Average Times: 128

Meas. Interval (μ s): 2.5