

Technical note

MAY 2021



ORCA[®]-Quest

qCMOS[®] camera

C15550-20UP

Table of contents

Introduction	P3	8. Various Timing Charts	P18
1. Key Features	P3	8-1. Explanation of timing charts	
1-1. Readout noise		8-2. Standard and Ultra quiet scan mode	
1-2. Photon number resolving		8-3. Normal area and photon number resolving modes	
2. Sensor Features	P7	8-4. Light sheet mode	
2-1. Sensor readout structure		9. Understanding SNR	P22
2-2. Back illuminated sensor		9-1. SNR	
2-3. Deep trench isolation structure		9-2. rSNR	
2-4. On-chip micro lens		9-3. Camera Simulation Engine	
2-5. Quantum efficiency		10. Application Examples	P23
2-6. MTF (Modulation Transfer Function)		10-1. Quantum technology (Neutral atom, Ion trap)	
2-7. Etaloning-desensitized		10-2. Astronomy (Lucky / Speckle imaging)	
2-8. Sensor size		10-3. Life science (Delayed fluorescence of plants)	
2-9. Digitization		10-4. Raman spectroscopy	
2-10. Simultaneous dual-row readout with single direction		11. Specifications	P25
3. Camera Features	P10	11-1. Specification chart	
3-1. Readout and frame rate		11-2. Dimensional Outlines	
3-2. Camera structure and features		11-3. System Configuration	
4. Readout Modes	P12	11-4. Options	
4-1. Readout modes			
4-2. Scan modes			
4-3. Operation modes			
4-4. Other readout modes			
5. Synchronization	P14		
5-1. Synchronization with other instruments			
5-2. Trigger input			
5-3. Trigger output			
5-4. Master pulse			
6. Data Managements	P16		
6-1. Selectable pixel bit depth			
6-2. User selectable Look Up Table (LUT)			
6-3. Real-time defect pixel correction			
7. Software Support	P17		
7-1. DCAM-API			
7-2. DCAM-SDK & DCIMG-SDK			
7-3. Hamamatsu software			
7-4. Third party software support/options			

Introduction

The ORCA[®]-Quest is the first quantitative CMOS (qCMOS[®]) camera which has photon number resolving capability. Photon number resolving is unique and quite different from photon counting (more precisely the method resolves the number of photoelectrons. However, since single photon counting instead of single photoelectron counting has been used as a comparable method in this field, we will use the term “photon number resolving” in this technical note).

Photon counting is well-known as a quantitative method of measurement because it can mitigate the readout noise (electronic circuit noise) and multiplication noise (excess noise). It is often used with photomultiplier tubes (PMT) and 2D sensors such as EM-CCD and Intensified CCD cameras. They all have the electron multiplication function which enables photon counting and the ability to distinguish between zero or one photon. However they cannot count multiple photon numbers like one, two, three, etc., because the electron multiplication function generates noise which detrimentally effects the ability to count multiple photons.

The ORCA[®]-Quest has extremely low readout noise and can therefore realize photon counting. Since the ORCA[®]-Quest can achieve photon counting without an electron multiplication function, it can also count multiple photons (This is called “Photon number resolving”). This photon number resolving method enables accurate and quantitative measurements in a wider range of photons than a standard photon counting method. Additionally, the ORCA[®]-Quest has not only photon number resolving but also a large pixel number of 9.4 megapixels. It is much larger than the EM-CCD’s pixel number of 1 megapixel. (Refer to Hamamatsu’s white paper, “qCMOS[®]: Quantitative CMOS technology enabled by Photon Number Resolving”).

The ORCA[®]-Quest has a lot of unique features ideal for a wide range of imaging applications in addition to photon number resolving, and we will introduce them in this technical note.



qCMOS[®] sensors

1. Key Features

1-1. Readout noise

1-1-1. Readout noise

Fundamentally, a camera has three to four types noise sources: readout noise, dark current noise, photon shot noise and in the case of electron multiplying cameras, excess noise. (Refer to the white paper “ORCA[®]-Flash4.0 Changing the Game”, https://www.hamamatsu.com/resources/pdf/sys/e_flash4_whitepaper.pdf). The excess noise is a unique to EM-CCDs, and is not present in CCD and CMOS cameras. In the absence of excess noise, the readout noise becomes the noise which determines the low light performance of the camera. Especially for qCMOS[®], the readout noise is the most important as photon number resolving capability can only be performed with extremely low readout noise.

The dominant factor of readout noise is the noise generated at the floating diffusion amplifier (FDA) of the sensor. The qCMOS[®] is designed to minimize the readout noise using cutting edge technology. Not only in optimizing the FDA but also the correlated double sampling (CDS) and other electronics, give the ORCA[®]-Quest the lowest readout noise which has never been seen before.

1-1-2. Readout noise measurement method

Since the CCD image sensor has one readout amplifier per sensor, the readout noise of multiple pixels in a single image can be utilized to measure the read noise.

In contrast, as the CMOS image sensor has an amplifier for each pixel, the readout noise is different for each pixel. Therefore, the readout noise in each pixel (called pixel readout noise) must be measured from hundreds of images first. The median and root mean square (rms) noises are statistically calculated from the distribution of those pixel readout noises. In CMOS cameras of other manufacturers, Median readout noises are used for camera readout noises. Since the median ignores the shape of the distribution of readout noise present in CMOS cameras, especially for sCMOS cameras, the RMS is used for the metric which includes the shape of the distribution recently. Together, both metrics provide an estimate for the noise distribution across the sensor, which can be seen in Fig. 1-1. In some sCMOS cameras the medians are significantly lower than RMS, therefore it is important to compare cameras by the same metric.

1-1-3. Readout noise performance

Fig. 1-1 shows typical pixel readout noise distributions of qCMOS® (in red), Gen III sCMOS (in green) and Gen II sCMOS (in blue). It clearly shows that distribution shapes are different for each sensor. The distribution of qCMOS® has the lowest peak, the narrowest FWHM and a short thin tail. The distribution of Gen III sCMOS has the second lowest peak, the second narrowest FWHM and a short thick tail. The distribution of Gen II sCMOS has the highest peak, the widest FWHM and a long thick tail.

The anti-symmetrical shape of the distribution results in a wide variation of statistical readout noise values. The RMS readout noises of qCMOS® is 0.27 electrons, mean readout noise is 0.24 electrons, median readout noise is 0.21 electrons and mode readout noise is 0.19 electrons. They show a half of pixel readout noises are less than 0.21 electrons and peak pixel readout noise is 0.19 electrons.

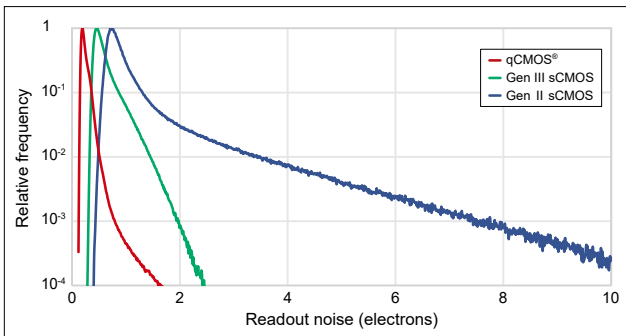

Fig. 1-1. Typical pixel readout noise distributions

1-1-4. Cumulative pixel number ratio for readout noises

Fig. 1-2 shows typical cumulative pixel number ratio for readout noises of qCMOS®. It shows 95.5 % of pixels are less than 0.40 electrons rms, 82.5 % are less than 0.3 electrons and 75.1 % are less than 0.27 electrons rms.

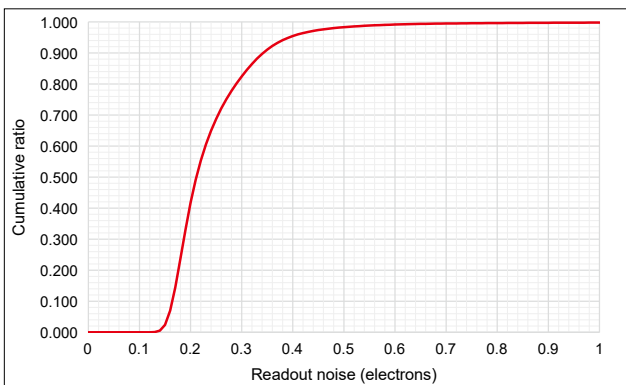

Fig. 1-2. Typical cumulative pixel number ratio for readout noises of qCMOS®

1-2. Photon number resolving

1-2-1. Photon number resolving

As mentioned, photon number resolving is quite different from photon counting. Photon counting cameras which use multiplication gain such as EM-CCDs or ICCDs to accomplish the low noise needed for counting photons can never realize photon number resolving because of their excess multiplication noise. On the contrary, qCMOS® achieves the low noise for photon counting without the multiplication gain, and therefore without the multiplication noise.

Fig. 1-3 shows the probability distribution of the observed photoelectrons for a Poisson distribution $P_3(k)$ with a mean of $N = 3$ photoelectrons, and three different values of the readout noise: $\sigma_R = 0.5$ electrons rms (blue curve), $\sigma_R = 0.3$ electrons rms (red curve), and $\sigma_R = 0.15$ electrons rms (green curve). The smaller the readout noise is the deeper the valleys between the photoelectron peaks. If the CMOS sensor can reduce the readout noise, it enables photon number resolving.

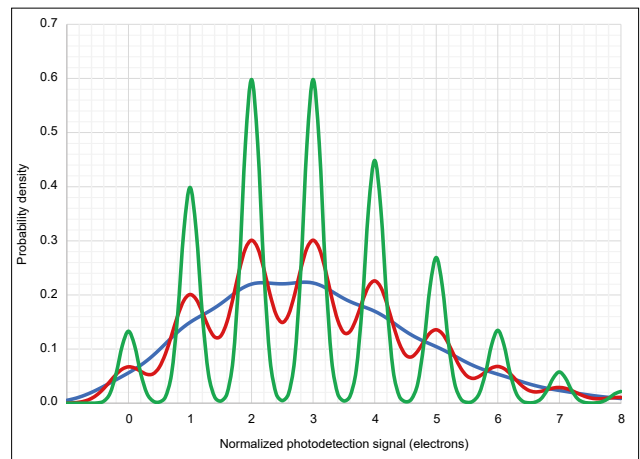

Fig. 1-3. Probability distribution of the observed photoelectrons for a Poissonian distribution $P_3(k)$ with a mean of $N=3$ photoelectrons, and three different values of the readout noise: $\sigma_R=0.5$ electrons (blue curve), $\sigma_R=0.3$ electrons (red curve), and $\sigma_R=0.15$ electrons (green curve).

The following graph is real qCMOS® data measured with a single pixel and hundreds of frames. The readout noise of the pixel is 0.16 electrons. The average generated photoelectron number is 2 electrons. The real distribution at approx. 2 electrons seems almost the same as the simulated distribution.

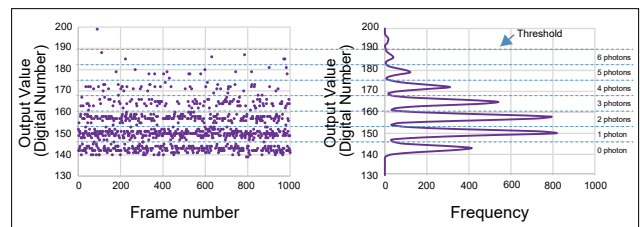

Fig. 1-4. Average generated photoelectron number: approx. 2 electrons, Readout noise: 0.16 electrons

The following graph is also real qCMOS® data measured with a single pixel, the readout noise of which is 0.16 electrons. The average generated photoelectron number is 55 electrons. Even with a large photoelectron number, the distribution can show the valleys clearly.

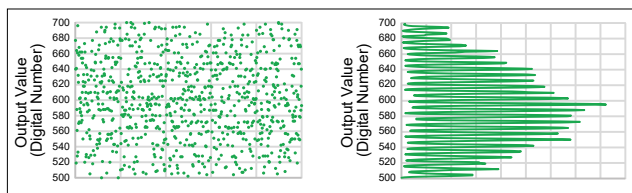

Fig. 1-5. Average generated photoelectron number: 55 electrons, Readout noise: 0.16 electrons

1-2-2. Error rate

The error rate is the percent probability that each data sample can be classified as an incorrect photon number, or false data. As this error rate increases, the valleys between the photoelectron peaks become shallower and the photon number becomes more difficult to resolve. This probability that the data sample will be classified as the next higher, or next lower photoelectron number is dependent the sample distribution caused by the readout noise. To make photon number resolving possible there should be a high probability that the data sample will be within ± 0.5 electrons of the nominal number. Conversely, this means that the error rate needs be low that the data sample will fall outside of this range.

Fig. 1-6 shows the -0.5 electrons to $+0.5$ electrons error rates vs readout noise for a range of readout noises to include those shown in Fig. 1-3. From this curve it can be noted that for a readout noise of 0.5 electrons rms, then 31.7 % of the data samples will be false. If the readout noise is 0.25 electrons rms, then 4.6 % of the data samples will be false, and if the readout noise is 0.167 electrons rms, then 0.3 % of the data samples will be false.

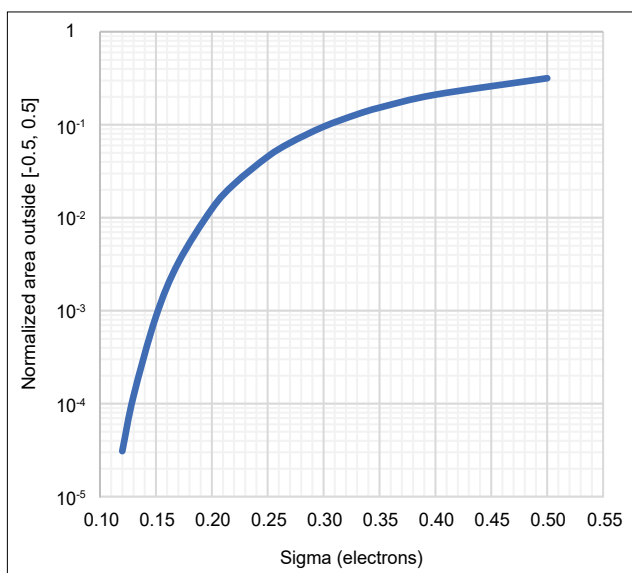

Fig. 1-6. Error rates vs readout noise

1-2-3. Readout noise at photon number resolving

Photon number resolving (PNR) is a method that converts output signals of the electron number from real number to an integral number. As we can estimate from Fig. 1-3, the numbers after the decimal point are made by the readout noise. If the readout noise is very small, the numbers after the decimal point can be removed by the PNR method. On the contrary, if the readout noise is not small, then the readout noise is detected in its error rates.

Fig. 1-7 shows simulated readout noise when it is measured with the PNR method. If the original readout noise is less than 0.3 electrons, then the readout noise with PNR method is smaller than original. If the original readout noise are 0.2 electrons, the readout noise with the PNR method become approximately 0.1 electrons. If the original readout noise is 0.1 electrons, the readout noise with the PNR method becomes approximately 0 electron.

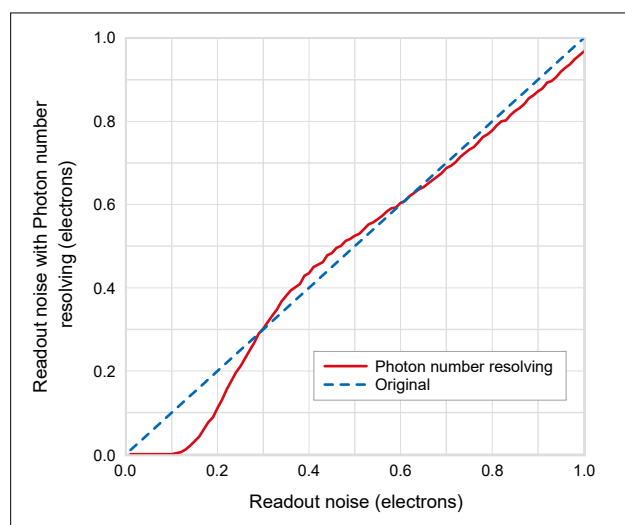

Fig. 1-7. Readout noise at photon number resolving

1-2-4. Photon number resolving mode

The ORCA®-Quest has a photon number resolving mode which can output the electron number by adapting the photon number resolving method inside the camera. When the photon number resolving mode is selected, the scan speed is set to Ultra quiet scan mode and one count of output data becomes one electron. The sensor pixel gains are different in pixel by pixel, but the photon number resolving mode can output the more precise photon number by correcting pixel gain differences inside the camera. As photon number resolving is valid to only a high gain amplifier with low noise, the maximum output of photon number resolving mode becomes 200 counts which is equivalent to 200 electrons.

1-2-5. Merit of photon number resolving mode

The merit of photon number resolving mode is that it has a wider detectable photon number range when compared to traditional photon counting cameras. It has the potential to provide superior measurement in linearity.

With the photon counting camera, the input photon number for each pixel must be less than one pixel/frame to keep good linearity. However, it is very difficult for photon counting cameras to keep less than one electron/pixel/frame on all pixels because it can output just zero or one electron. The users try to estimate whether all pixels are less than one electron/pixel/frame or not by calculating the mean of some frames. If not, they must reduce the input photon number to less than one electron/pixel/frame by any means or give up the measurement with good linearity.

With the photon number resolving mode of the ORCA[®]-Quest, the camera outputs photon numbers and it can be used at signal level less than 200 electrons/pixel/frame while keeping good linearity.

The photon number resolving mode is very useful for precise imaging when there are both high and low photon number regions.

1-2-6. Binning in photon number resolving mode

As described in section “4-4-2 Binning readout”, the binning is a method of adding the signal of adjacent pixels together to achieve high sensitivity at the cost of resolution. This binning for CMOS sensors which is called digital binning, adds not only signals but also readout noises. However, ORCA[®]-Quest’s readout noise is very small even when increased by binning. Additionally, as Fig. 1-7 shows, readout noises with the PNR method become smaller than the original readout noises.

In terms of binning and PNR method, we have two alternatives, the first is performing the PNR method before binning, and the second is performing binning before PNR method. Since the PNR method has higher merit for low readout noise, the ORCA[®]-Quest performs the PNR method before increasing the readout noise by binning.

2. Sensor Features

2-1. Sensor readout structure

The following figure is the readout structure of the ORCA[®]-Quest qCMOS[®] sensor very similar to standard sCMOS sensor. Each pixel has a photodiode (PD) and Floating Diffusion Amplifier (FDA). At the PD the photons are converted to photoelectrons and at the FDA the photoelectrons are converted to voltages. The FDA is the dominant source of readout noise of the sensor. Each column has two Correlated Double Samplings (CDSs) and column Analog to Digital Converters (ADCs). Even and odd rows are readout simultaneously from top to bottom. Even and odd rows are readout through different CDSs and ADCs.

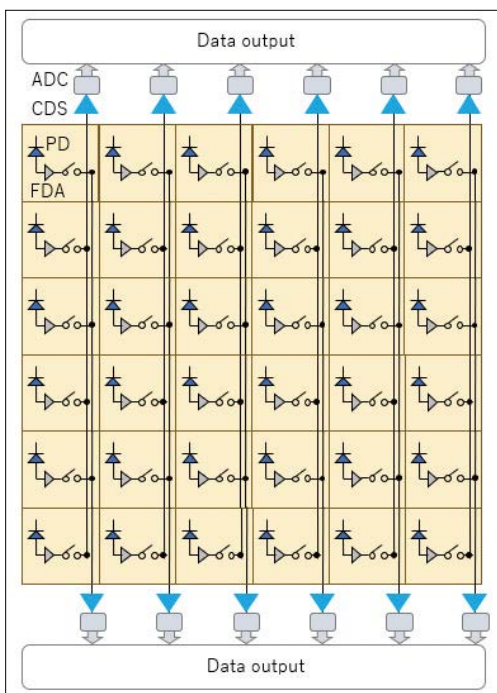

Fig. 2-1. Sensor structure

2-2. Back illuminated sensor

The ORCA[®]-Quest qCMOS[®] sensor has a cutting edge back illuminated sensor which has not only high QE, but also high resolution.

2-3. Deep trench isolation structure

The ORCA[®]-Quest features a deep trench pixel structure, an innovation in scientific image sensors. The back illuminated sensor is thinned to less than 20 μm thickness to achieve higher resolution in short and visible wavelengths. For a sensor with a small pixel size, a thinner sensor is necessary for good resolution. On the contrary, thinner sensors cause the lower quantum efficiency in near infra-red wavelength (NIR). So there is a trade-off between resolution and quantum efficiency depending on the sensor thickness.

The ORCA[®]-Quest has a sensor which has enough thickness for NIR-QE with a deep trench structure in each pixel, and it enables both good resolution and NIR-QE with the small sensor size of 4.6 μm square even. The trench structure can reflect the input photons and prevent them from reaching the adjacent pixels. It prevents not only the input photons, but also the photoelectrons from migrating to the adjacent pixels.

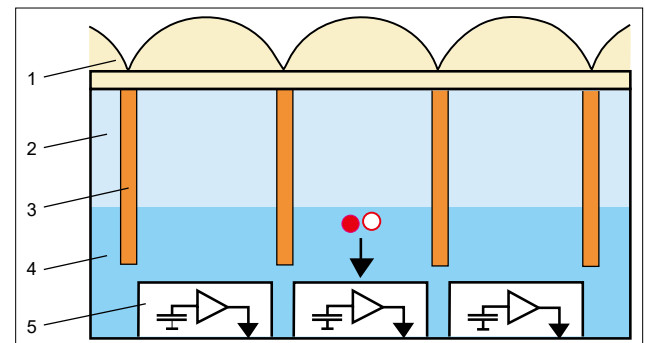

Fig. 2-2. Schematic cross section through the back-illuminated qCMOS[®] image sensor showing DTI (Deep Trench Isolation) structures and microlenses on top.

1: Microlenses, 2: Field-free region (photocharge transport through diffusion), 3: DTI (Deep Trench Isolation) structures, 4: Electric field region (photocharge transport through drift), 5: Pixel structure for electronic photocharge detection

2-4. On-chip micro lens

The ORCA[®]-Quest has an on-chip micro lens in each pixel. The microlenses compensate for the loss in active area due to the DTI structures and therefore maximize QE.

2-5. Quantum efficiency

The following figure is the QE curve of the ORCA®-Quest. The peak QE is 90 % at 475 nm, 33 % at 900 nm and the QE in the infrared between 750 nm and 1000 nm is quite high, even with the small pixel size of 4.6 μm square.

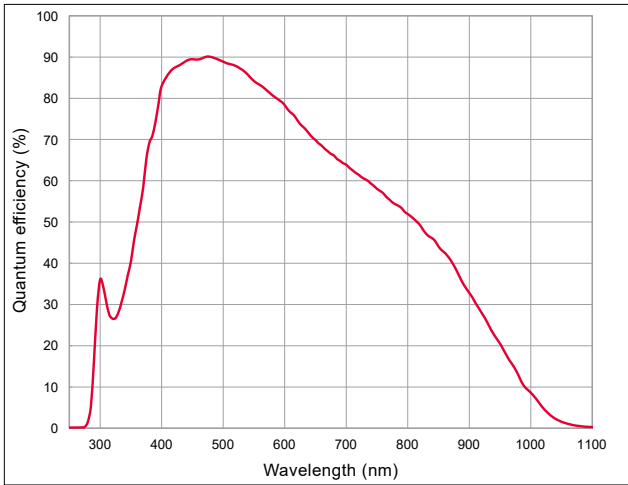

Fig. 2-3. QE curve

2-6. MTF (Modulation Transfer Function)

The qCMOS® sensor has a deep trench structure which isolates pixels and limits the electrons transferring to neighboring pixels. It causes the increase of MTF. Fig. 2-4 shows MTF comparison at 565 nm between qCMOS® and BSI Gen II sCMOS where the qCMOS® shows better MTF. Since the pixel sizes of the two sensors are different, this graph shows normalized MTF compensating for the difference in pixel sizes.

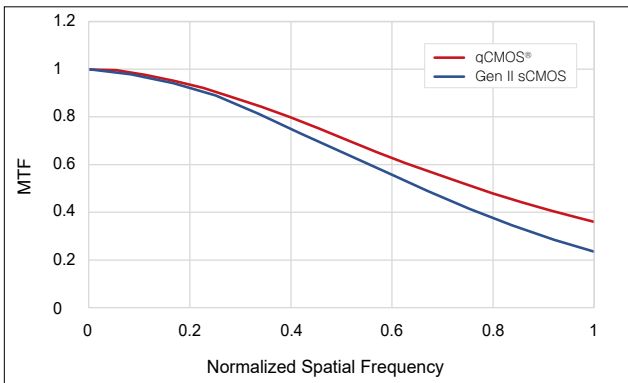

Fig. 2-4. Comparison of MTF normalized to Nyquist at 565 nm between qCMOS® camera and BSI Gen II sCMOS camera

2-7. Etaloning-desensitized

Etaloning is a phenomenon that the sensitivity varies depending on the spatial and spectral position when the incident light interferes with the reflected light from the back surface of the silicon.

Fig. 2-5 shows image difference between a BSI EM-CCD and qCMOS® with uniform monochrome light input. While the EM-CCD shows fringe patterns even with uniform monochrome light input, the qCMOS® does not shows them clearly.

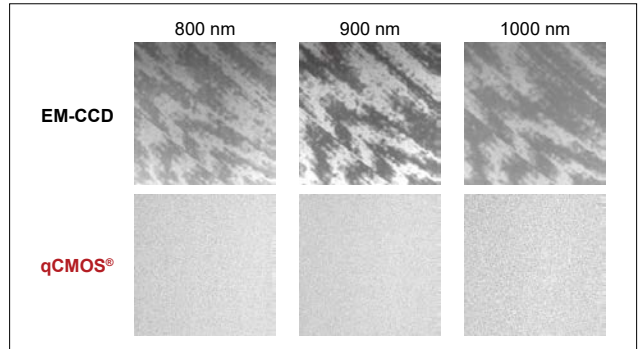

Fig. 2-5. Etaloning-desensitized

2-8. Sensor size

While the pixel size of the qCMOS® sensor is smaller than most other scientific sensors, the pixel number is higher. A diagonal of 21.6 mm has good compatibility with a microscope objective with a field number of 22 and a Four Thirds lens with an image circle of 21.63 mm.

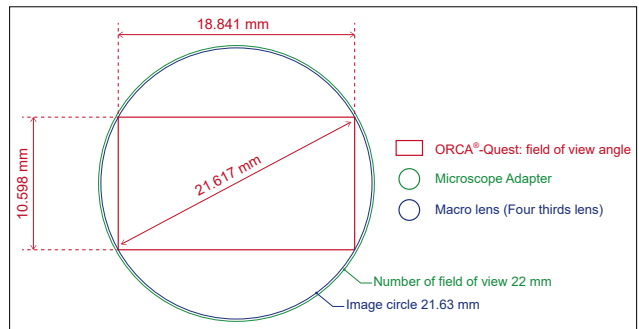

Fig. 2-6. Sensor size

Fig. 2-7 shows the pixel number difference of qCMOS®, Gen II sCMOS and EM-CCD. If the pixel resolutions are adjusted the same optically, the qCMOS® can acquire the wider area than other cameras.

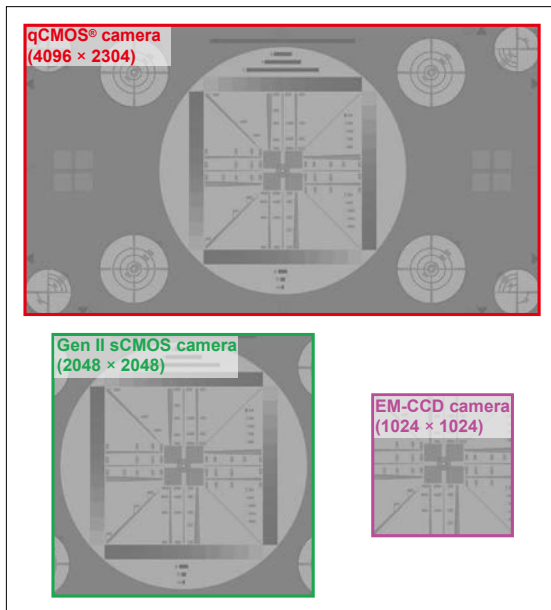

Fig. 2-7. Comparison of the pixel number between qCMOS® camera, Gen II sCMOS camera and EM-CCD camera when pixel sizes are optically matched

2-9. Digitization

As explained in sensor readout structure, the ORCA®-Quest qCMOS® sensor has two column ADCs in upper and bottom side for each column. A column ADC has both an AMP and ADC for high gain and for low gain. The ADCs for high and low are 11 bit, and 16 bit output is provided by combining both high and low 11 bits in the Field Programmable Gate Array (FPGA).

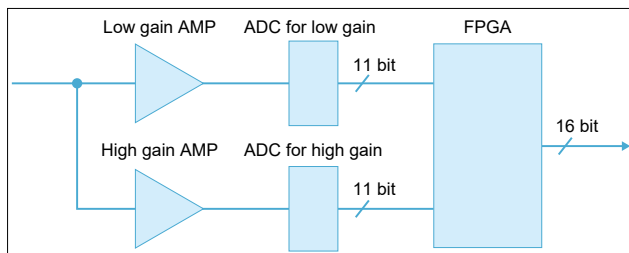

Fig. 2-8. Digitization structure

2-10. Simultaneous dual-row readout with single direction

As explained in sensor readout structure, the ORCA®-Quest qCMOS® sensor has two column ADCs in top and bottom side for each column. The dual rows are readout simultaneously with a single direction from top to bottom (or bottom to top) and it is quite different from the dual directions of a Gen II CMOS sensor. The ORCA®-Quest qCMOS® sensor is designed as a rolling shutter sensor instead of a global shutter sensor, to attain a readout noise even lower than the Gen II CMOS sensor.

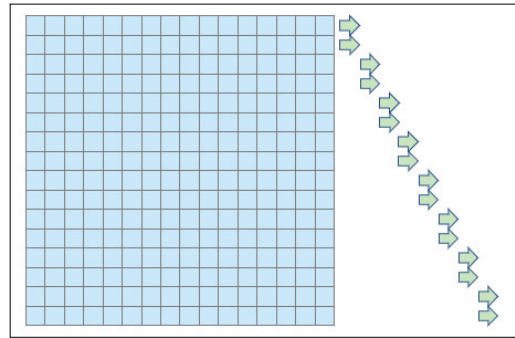

Fig. 2-9. Simultaneous dual-row readout with single direction

3. Camera Features

3-1. Readout and frame rate

3-1-1. Frame rate (readout speed)

The frame rate (readout speed) refers to the number of images that can be continuously produced and is specified in frames per second (fps). The maximum full frame rate of the ORCA[®]-Quest is 120 frames/s (at 4096 × 2304 pixels) and is achieved using a simultaneous dual-row readout with single direction.

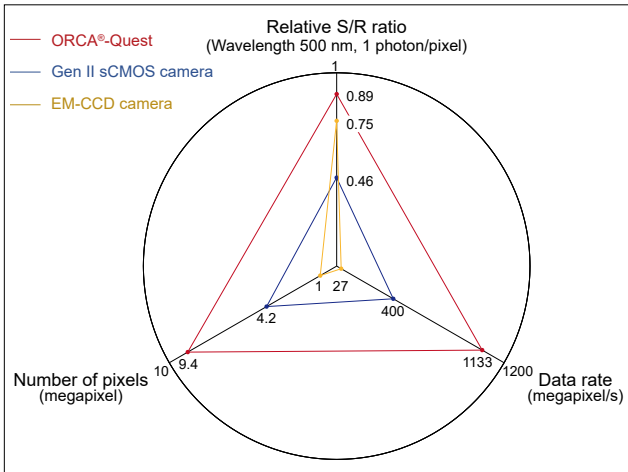

Fig. 3-1. Frame rate and pixel number

3-1-2. CoaXpress and USB 3.1 Gen 1 interfaces

The need to image at speeds higher than 30-40 fps is highly dependent on the experimental conditions and scientific questions. Since high speed imaging comes with additional costs and considerations, the ORCA[®]-Quest was designed to be versatile. Every ORCA[®]-Quest can be used with either USB 3.1 Gen 1 or CoaXpress. CoaXpress boards and cables can be added at the time of purchase or later as experimental needs evolve. CoaXpress is the state-of-the-art high speed camera interface that enables capturing large quantities of image data quickly. Our DCAM drivers are optimized for either interface and the chart below shows the speed tradeoff for a range of common ROI sizes.



Fig. 3-2. CoaXpress and USB 3.1 Gen 1

3-1-3. CoaXPress interface

When connecting with the CoaXPress interface, images of 9.4 megapixel and 16 bit each can be transferred to a computer in 120 frames/s (full frame). The interface speed is even higher than the sensor readout speed and it means there is no compromise in speed with the CoaXPress interface.

3-1-4. USB 3.1 Gen 1 interface

The USB 3.1 Gen 1 interface is a general-purpose interface with a maximum speed of 500 MB/sec. It comes as standard with many computers and is equipped in many notebook computers. The maximum frame rate in USB is 17.7 frame/s with full frame. However, the ORCA[®]-Quest offers user-controllable Look Up Tables (LUT) for 8 bit or 12 bit data in order to record only the necessary range of digital output. With this capability, users can not only reduce image data volume but also improve the camera frame rates by eliminating the need to record unnecessary image data.

Table 3-1. Maximum frame rates with sub-array

ROI	Scan modes	CoaXPress	USB		
		16 bit	8 bit	12 bit	16 bit
4096 × 2304	Standard	120	35.3	23.5	17.7
	Ultra quiet	5.0	5.0	5.0	5.0

3-2. Camera structure and features

3-2-1. Water and air (fan) cooling

In a design similar to the ORCA®-Flash4.0 and ORCA®-Fusion/ORCA®-Fusion BT, the ORCA®-Quest is enabled for either fan or water cooling. In most cases the cooling achieved by the fan is sufficient to reduce the dark current to insignificant levels. Water cooling also reduces vibrations from the fan.



Fig. 3-3. Water and air (fan) cooling

3-2-2. Dark current

The ORCA®-Quest has two target temperatures, stable cooling and maximum cooling. When stable cooling is selected, the sensor temperature goes down to -20°C and the typical dark current achieved is 0.016 electrons/pixel/s. When maximum cooling is selected, the sensor temperature goes down to -35°C and the typical dark current achieved is 0.006 electrons/pixel/s.

3-2-3. Fan vibration

The fan vibration of the ORCA®-Quest is designed to be sub-pixel level with 100x objective on an inverted microscope. Fig. 3-4 shows the vibration difference between Fan-on and Fan-off. The pure vibration of the fan is estimated by subtracting Fan-off from Fan-on.

In the case the minimal fan vibration is too much for the experiment, the water cooling becomes another alternative.

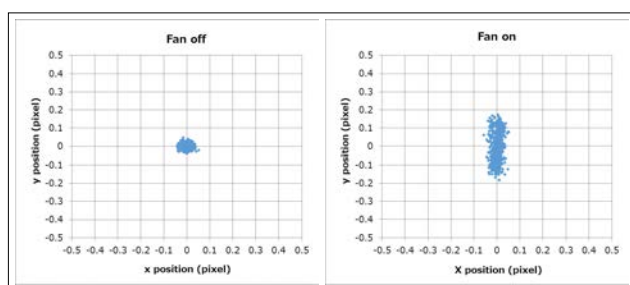

Fig. 3-4. Fan vibration

3-2-4. Wide operation temperature

In a perfect lab environment, the temperature and humidity would be tightly controlled and stable. Unfortunately, this is often not the case especially in labs in tropical and/or humid summer climates. In these conditions, if the room humidity exceeds the operating humidity specification of the camera, the front window of the camera can develop condensation and destroy image quality. To prevent this the ORCA®-Quest was designed with a wide operating temperature and humidity range.

Table 3-2. Operating temperature and humidity

Operating temperature	0 °C to +40 °C
Operating humidity	30 % to 80 % without condensation

4. Readout Modes

A camera is just one piece of a complicated imaging system. To successfully integrate the ORCA®-Quest into many imaging scenarios we offer numerous camera modes which are realized with the combination of readout modes, scan modes and operation modes.

4-1. Readout modes

Readout modes offered are normal area mode, photon number resolving mode and light sheet mode.

4-1-1. Normal area mode

Normal area mode is a fundamental mode offered by all standard 2D cameras.

4-1-2. Photon number resolving mode

Photon number resolving mode is a unique mode of the ORCA®-Quest which can count the number of photons (photoelectrons).

4-1-3. Light sheet mode

Light sheet mode is a special mode which is applicable for the readout of Digital Scanned Light sheet Microscopy (DSLM). By synchronizing the camera row scan speed with the beam scanning speed and arranging the exposing row widths with the beam width, the high contrast image is acquired by removing the fluorescent light from the out-of-focus plane.

4-2. Scan modes

The ORCA®-Quest has two scan modes, Standard scan mode and Ultra quiet scan mode. The readout noise is the most important noise for low light imaging, and it is well-known slower scan speed gives lower readout noise. However, since the slower scan speed also gives a slower frame rate, the scan speed should be selected according to the imaging scenario.

4-2-1. Standard scan mode

In Standard scan mode, the ORCA®-Quest can achieve a fast frame rate of 120 fps with the full frame of 9.4 megapixels. It is equivalent to a pixel rate of 1.13 gigapixels per second. Even at the fast frame rate and pixel rate, the readout noise of 0.5 electrons rms is the higher level of that offered by CMOS cameras.

4-2-2. Ultra quiet scan mode

In Ultra quiet scan mode, the ORCA®-Quest can achieve the lowest readout noise which enables photon number resolving. In this mode the frame rate is 5 fps with a full frame of 9.4 megapixels.

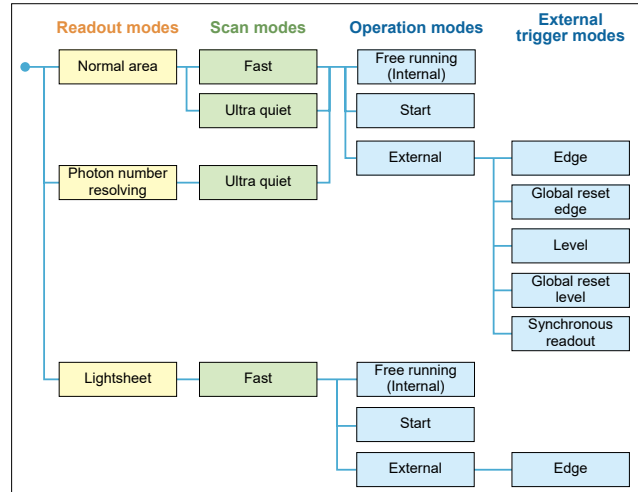

Fig. 4-1. Various readout modes

4-3. Operation modes

As a camera is just one piece of a complicated imaging system, it is used with other instruments. With some instruments e.g. light source, shutter, x-y stage, camera synchronization is sometimes necessary. The ORCA®-Quest has three operation modes for the trigger.

4-3-1. Free running mode (internal trigger mode)

In free running mode, which is sometimes called internal mode, the camera operation timing is synchronized with the internal trigger generated inside the camera. If synchronization is needed, other instruments can use the output trigger from the camera for synchronization. In this synchronization the camera is master and other instruments are slaves. The ORCA®-Quest has many output triggers which are described later.

4-3-2. Start trigger mode

In start trigger mode, the camera operation is started synchronizing with one pulse (one trigger) from the other instruments. The first exposure of the camera is synchronized with the input of the external trigger, but the second and later exposures are synchronized by the internal timing of the camera.

4-3-3. External trigger mode

In external trigger mode, the camera waits for the input trigger from the other instruments. Once the trigger is input, then the camera exposure for one frame starts, more triggers are required for more frames. The ORCA[®]-Quest has five external trigger modes, edge, global reset edge, level, global reset level and synchronous readout trigger.

All of them are selectable in normal area and photon number resolving modes. Only edge trigger mode is selectable in light sheet mode. The best external trigger mode is uniquely dependent on the application. The timing charts are described in the chapter "Various Timing Charts". The fine timing details of these modes are also described in the ORCA[®]-Quest camera manual and our worldwide sales and technical teams are available worldwide to provide customized support.

4-4. Other readout modes

4-4-1. Sub-array readout or Region of Interest (ROI)

Sub-array readout is a method of reading the sensor in which the output images are comprised of only the pixels in the user selectable region of interest (ROI). Since less data is being readout and transferred, this method can offer increased maximum frame rates with no increase in readout noise. Since CoaXPress speed is higher than the fastest sensor speed, the fastest frame rates are limited by sensor speeds that depend on both sub-array sizes and scan speeds. On the contrary, since USB speed is slower than the fastest sensor speed, frame rate with USB are limited by the interface speed and can be improved with sub-array sizes and scan speeds. Table 4-1 shows maximum frame rates of CoaXPress and USB at standard scan speed. When the horizontal pixel number is less than 512 pixels at USB, maximum frame rates are the same with those of CoaXPress. It indicates maximum frame rates are limited by the sensor speed when the horizontal pixel number of less than 512.

Table 4-1. Maximum frame rates of CoaXPress and USB at standard scan mode

Number of pixels in vertical direction	CoaXPress	USB			
	Number of pixels in horizontal direction				
	4096	512	1024	2048	4096
2304	120	120	70.7	35.3	17.6
2048	134	134	79.5	39.8	19.9
1024	268	268	158	79.3	39.9
512	532	532	315	157	78.9
256	1044	1044	622	312	156
128	2012	2012	1218	609	304
4	19841	19841	19841	8169	4084

4-4-2. Binning readout

Binning is a method of adding the signal of adjacent pixels together to achieve high sensitivity at the cost of resolution. Binning can improve the signal to noise ratio, the maximum frame rates with USB connection and the image data sizes. The ORCA[®]-Quest does in-camera binning of either 2×2 or 4×4 pixels with a resultant increase in S/N of 2× and 4×, respectively. A 2×2 bin of the entire sensor (4096 × 2304) would result in a quadrupling of the signal in each pixel, a 2 fold increase in S/N and an image that is 2048 × 1152 pixels. The resultant increase in speed would depend on the output interface being used as shown in Table 4-2. The image data size are reduced to 1/4 with 2×2 binning and 1/16 with 4×4 binning.

Table 4-2. Readout speed of binning readout method

Number of pixels in vertical direction	CoaXPress	USB		
	1×1, 2×2, 4×4	1×1	2×2	4×4
2304	120	17.6	35.3	70.7
2048	134	19.9	39.8	79.5
1024	268	39.6	79.3	158
512	532	78.9	157	315
256	1044	156	312	622
128	2012	304	609	1218
4	19841	4084	8169	15432

5. Synchronization

5-1. Synchronization with other instruments

As a camera is just one piece of a complicated imaging system, it is often necessary for it to be used in synchronization with other instruments. In some cases, the other instrument is a camera. The fastest synchronization is established with an electrical signal by connecting the cable between the instruments. In synchronization, only one instrument becomes a master, including cameras, and all others become slave instruments.

5-1-1. Use the camera as a slave instrument

External trigger mode is the operation mode used when the ORCA[®]-Quest is a slave instrument. The camera has a trigger input connector and is synchronized with the pulse from other instruments.

5-1-2. Use the camera as a master instrument

There are three operation modes in which the ORCA[®]-Quest is used as a master instrument. The first is free running mode, the second is start trigger mode and the last is external trigger mode with the master pulse. They all use the internal trigger generated inside the camera. The camera has three trigger output connectors and three types of trigger output signals are selectable for synchronizations with other instruments.

5-2. Trigger input

To synchronize the camera with other instruments, the camera uses the trigger input signal from the other instruments through the trigger input connector. The signal level needs TTL or 3.3 V LVCMOS and both positive and negative polarity is selectable. The input trigger can be delayed with the programable delayed time of 0 μ s to 10 s by 1 μ s step. Trigger times is a function that allows the number of enabled triggers to be reduced by the ratio of the times number. For example, if the Trigger times is four, three trigger inputs are ignored, and the next trigger input is enabled.

5-3. Trigger output

To synchronize other instruments with the camera, ORCA[®]-Quest has three trigger output connectors and various trigger output signals.

5-3-1. Global exposure timing output

The camera simultaneously outputs the period where all rows are exposed. Since the timing of the exposure in each row is different for the rolling shutter, it is possible that a phenomenon may be observed partially in each of two consecutive frames. Global exposure timing allows for synchronizing of the event to the time when all rows are exposing, therefore moving the event into a single frame. Exposure should be set to longer than the readout to take advantage of this synchronization.

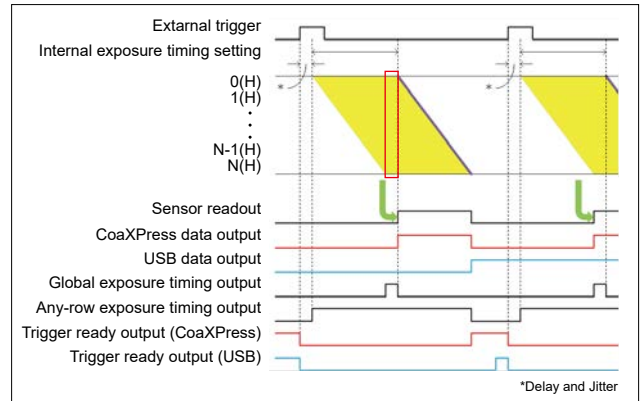

Fig. 5-1. Global exposure timing output

5-3-2. Any row exposure timing output

Since the timing of the exposure in each row is different for the rolling shutter, the total exposure period from the start to the end of all rows is longer than the exposure time of a single row. Any row exposure timing output gives the start and end timing of the total exposure period of all rows and it is useful for synchronizing with other instruments.

5-3-3. Trigger ready output

When operating in external trigger mode, the interval from one exposure to the next can be shortened with the use of the trigger ready output. When the camera is operating in external trigger mode, for example for the edge trigger, the next exposure will start only after the sensor readout has ended. For this reason, a trigger for the start of the next exposure cannot be accepted during an exposure or readout. By monitoring the output signal at the end of readout the input trigger may be sent immediately to start the next exposure, to reduce the dead time as much as possible.

5-3-4. Programmable timing output

For the programmable timing output, pulses with a delay time and pulse width are set by a command, and referenced to the user selection of the end of the sensor readout, Vsync (vertical synchronous signal) or Hsync (horizontal synchronous signal). By using the programmable timing output, simple synchronization with external devices will be enabled, allowing it to replace a simple delay unit or pulse generator. The setting range of the time delay is 0 μ s to 10 s, and pulse width is 10 μ s to 10 s.

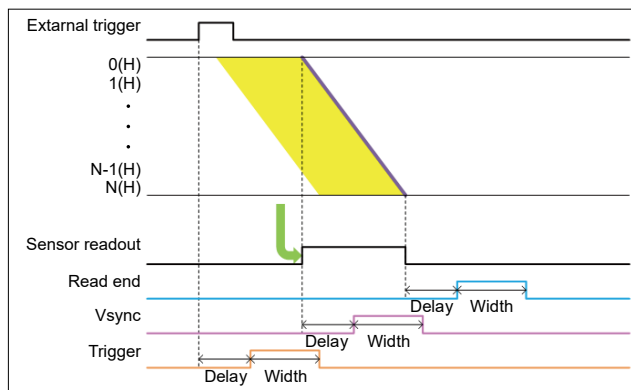

Fig. 5-2. Programmable timing output (normal area mode, edge trigger)

5-3-5. Pre-Hsync

In light sheet mode, a timing signal referenced to the row readout may be output by setting the Hsync output trigger. The delay and width are set by command. In addition, the start of the light sheet mode may be delayed by setting a number of Pre-Hsync pulses.

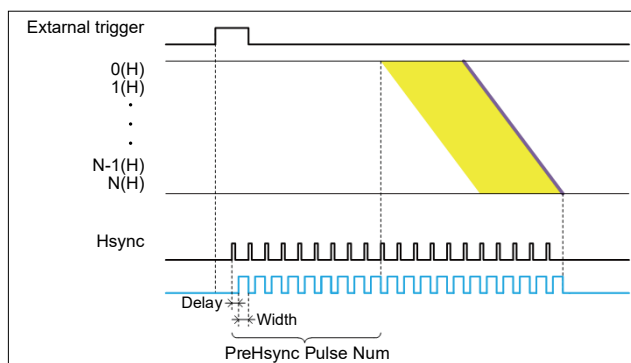

Fig. 5-3. Pre-Hsync

5-4. Master pulse

5-4-1. Master pulse

In some conventional systems, an additional external pulse generator is required to synchronize the camera and other instruments. The ORCA[®]-Quest has a master pulse function which can generate pulses that are independent of the exposure or readout timing of the image sensor. The camera can be synchronized with the master pulse in external trigger mode, except for Lightsheet readout mode. The camera can also output triggers which are synchronized with the master pulse.

5-4-2. Two cameras simultaneous exposure without an external pulse generator

The master pulse can realize simultaneous exposure of two cameras without an external pulse generator. When two cameras are connected with a trigger cable, the first camera is synchronized with its master pulse, the first camera outputs the trigger pulse synchronized with the master pulse, the second camera is synchronized with the output trigger from the first camera, the exposure of two cameras can be controlled to be the same timing.

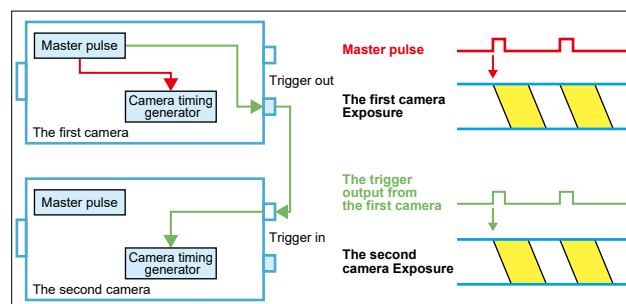

Fig. 5-4. Two cameras simultaneous exposure without an external pulse generator

5-4-3. Master pulse function

The master pulse function can be turned ON and OFF (Default is OFF). The master pulse has three modes, free running mode, start trigger mode and burst mode. The range of interval time is 10 μ s to 10 s, and the step is 1 μ s for the master pulse.

6. Data Managements

6-1. Selectable pixel bit depth

Using 8 bit (256 gray levels) or 12 bit (4096 gray levels) depth is a method to reduce the image data volume to a user significant intensity resolution. 12 bit digital output: The data is reduced to 3/4, of the 16 bit output. 8 bit digital output: The data is reduced to 1/2, of the 16 bit output. Thus 8 bit or 12 bit digital output can also boost the USB interface frame rates, while reducing image data volume.

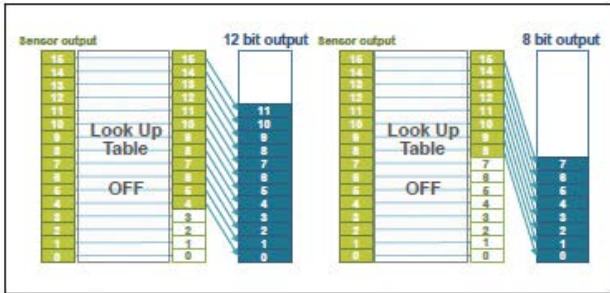

Fig. 6-1. LUT OFF

6-2. User selectable Look Up Table (LUT)

The reduced 8 or 12 bit-depth acquisition can result in the compression of pixel intensity data, thereby reducing intensity resolution. The user-controllable Look Up Table (LUT) can be used to regain intensity resolution by allowing a selectable, reduced range, of intensities to be mapped into the reduced bit-depth. Selectable LUT is adjustable up to 16 bit-depth resolution.

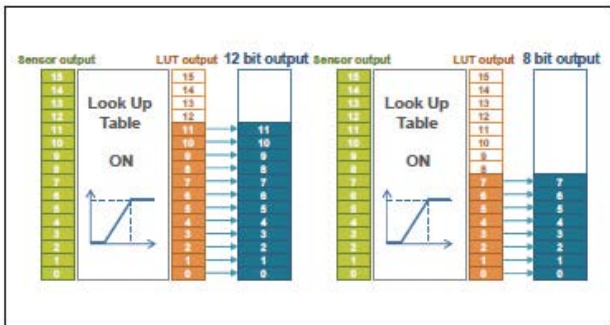

Fig. 6-2. LUT ON

6-3. Real-time defect pixel correction

As all CMOS image sensors have defect pixels, the sensor utilized in the ORCA®-Quest has a very small ratio of defect pixels to normal pixels. To reduce the effect of the defect pixels, the ORCA®-Quest has a real-time variant pixel correction feature. This correction is performed in real-time with no impact on image readout speed. The correction function can be turned on or off using the software, and the camera defaults to the ON condition when powered up. User selectable correction levels and associated exposure time examples are listed below.

Table 6-1. Ratio of defect pixel number to be corrected

Correction level for white spots	Number of pixels to be corrected
High	Thousands of pixels
Medium	Tens of pixels
Low	Several pixels

7. Software Support

7-1. DCAM-API

ORCA[®]-Quest is supported by DCAM-API, which is provided as driver software. DCAM-API supports many Hamamatsu digital cameras for scientific measurement, including the ORCA[®]-Quest, and is designed to absorb the difference in their properties and to allow control by a common calling method. DCAM-API supports Microsoft Windows and Linux. Please refer to Hamamatsu software information page at the link below.

<https://dcam-api.com/structure/>

For the latest detailed information such as compatible OS, I/F card and application software, please contact your local sales representative.

7-2. DCAM-SDK & DCIMG-SDK

SDK is a Software Development Kit for the integration of Hamamatsu digital cameras with the customer software. Users, depending on their requirements, may develop their own application software, for camera control with the DCAM-SDK and for recording DCIMG files with the DCIMG-SDK. DCAM-SDK and DCIMG-SDK can be downloaded from the link below after completion of user registration. The current DCAM-SDK4 and DCIMG-SDK supports C/C++ with increased language support expected in near future (including Python). Please refer to the Hamamatsu software information page at the link below.

<https://dcam-api.com/dcam-sdk-login/>

For the latest detailed information, please contact your local sales representative.

7-3. Hamamatsu software

Hamamatsu offers software products for use with all DCAM based Hamamatsu cameras, dedicated to life science applications: HCLImage and HoKaWo; for (bio-) physics and for industrial application, our HiPic software is the optimum choice. HSR software has limited functions and is easy. For the full range of Hamamatsu software, please refer to the following link:

https://camera.hamamatsu.com/all/en/software/hamamatsu_software/index.html

7-4. Third party software support/options

As imaging setups become more complex, software has to not only to control a camera, but many other devices such as microscopes, stages and filter wheels... Therefore, software companies have integrated Hamamatsu DCAM based cameras into their software products. Currently the ORCA[®]-Quest is supported in LabVIEW, MATLAB, and μ Manager. Third party software is listed on here.

http://camera.hamamatsu.com/all/en/software/third_party_software/index.html

8. Various Timing Charts

8-1. Explanation of timing charts

In Chapter 8, each imaging mode is described with reference to a timing chart. First, the chapter discusses how to read the timing charts. The horizontal axis in Fig. 8-1 represents the passage of time. The part colored in yellow represents the exposure condition of the CMOS sensor. The top of the figure represents the top of the image of the CMOS sensor, and the bottom of the figure represents the bottom of the image of the CMOS sensor. As the CMOS sensor controls the exposure in row increments, the transverse timing of the CMOS sensor is omitted in the figure. This figure shows the external trigger is input. After inputting an external trigger (1), a sensor readout (readout of the data in the previous frame) is started (2), and the first and second rows (0H, 1H) of the screen will start exposing at the same time. Refer to the section of "Simultaneous dual-row readout with single direction". At the end of exposure the sensor reads out and for the frame grabber interface the data output also starts (3). With the passage of time, the sequential readout of previous frames on a row-by-row basis and exposure of the next frame starts. In the period where all rows are exposed (red square in the figure), the global exposure timing output (4) is enabled. In addition, a trigger ready output (5) will be output once the readout of one frame is completed and the next external trigger reception is enabled, and if USB is connected, USB data output will be output (6).

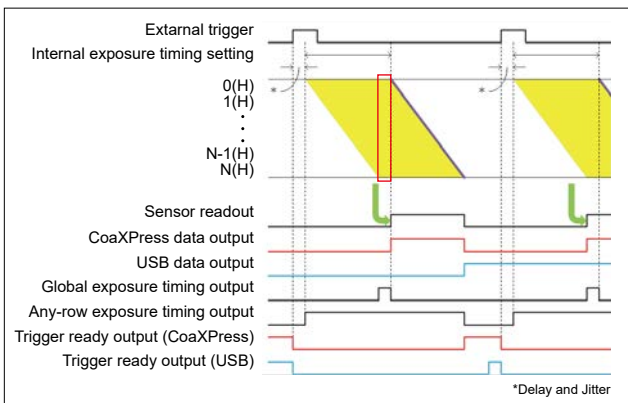

Fig. 8-1. Camera operation mode

8-2. Standard and Ultra quiet scan mode

In the Ultra quiet scan mode, the readout slope can be adjusted from 8.3 ms to 20 ms, and the fastest frame rate is 5.0 frames/s. As there is no change in the relationship of each trigger input and output other than the readout slope, please see the timing diagrams of Fig. 8-2 for the Ultra quiet scan.

The normal area mode has both Standard and Ultra quiet scan modes. Photon number resolving mode only has Ultra quiet scan mode. The Light sheet readout mode has only Standard scan mode

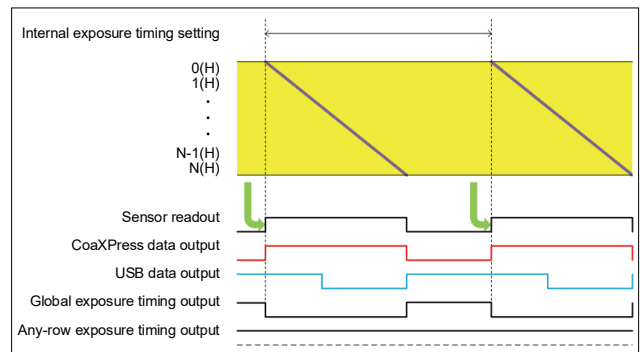

Fig. 8-2. Ultra quiet scan mode in free running mode

8-3. Normal area and photon number resolving modes

The normal area mode has both Standard and Ultra quiet scan modes. Photon number resolving mode has only Ultra quiet scan mode. The timing of both the normal area mode with Ultra quiet scan and photon resolving mode with Ultra quiet scan are the same. The difference between Standard and Ultra quiet scans is the slope of readout.

8-3-1. Free running mode

ORCA[®]-Quest allows the exposure time to be set by software and is equipped with a free running mode that operates in the camera itself. The free running mode is equipped with normal readout mode (when the exposure time is longer than the readout time of one frame) and electrical shutter mode (when the exposure time is shorter than the readout time of one frame). These modes automatically switch according to the exposure time setting.

8-3-1-1. Normal readout mode

The normal readout mode is a mode where the set exposure time is either the same as, or longer than the frame readout time. In this case there is the period called global exposure timing in which all pixels are exposed at the same. In that timing the global exposure timing output signal will be high. In normal readout mode there is no time when the pixels are not exposing (dead time) because exposure of the next image starts as soon as the pixel is read out.

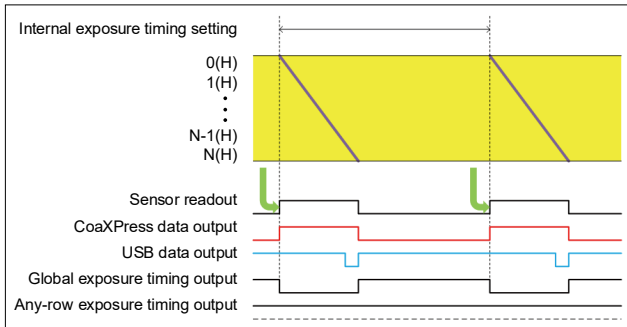

Fig. 8-3. Normal readout mode

8-3-1-2. Electrical shutter mode

The electrical shutter mode is used when the light intensity is too high and the output signal overflows in the normal readout mode. By adjusting the exposure time to shorter than the frame readout, the output signal can be reduced to a suitable signal level. As the exposure time is shorter than the frame readout time, there is no global exposure timing. The frame rate is at the maximum.

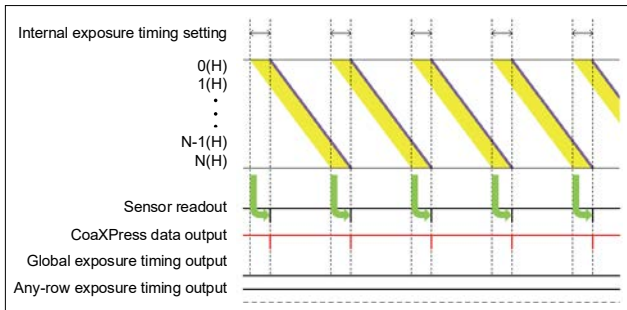

Fig. 8-4. Electrical shutter mode

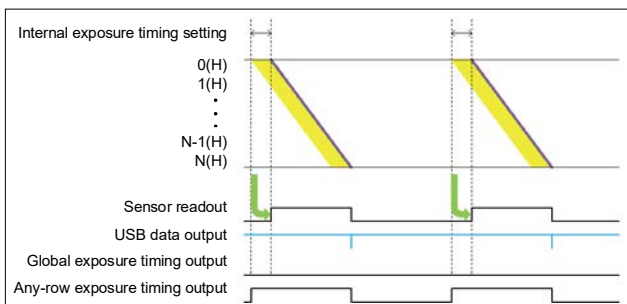

Fig. 8-5. Electrical shutter mode (USB)

8-3-2. External trigger mode

As described in the chapters of Readout modes and synchronizations, the ORCA®-Quest has various external trigger modes for synchronization with the input trigger from the other instruments.

8-3-2-1. Edge trigger mode

The edge trigger mode is used when performing exposure in synchronization with an external trigger signal. The exposure time is externally set using the software. In edge trigger mode, the exposure of the top row (0 H in the figure below) is started by the edge (rising/falling edge) timing of the trigger signal input to the camera. Then, after the readout time of the row, exposure of the next row (1 H) starts, after which each row successively starts exposure. Fig. 8-6 shows the timing chart of the rising edge example.

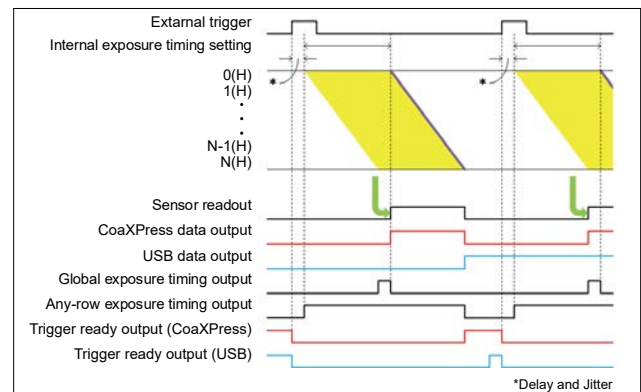

Fig. 8-6. Edge trigger mode

8-3-2-2. Global reset edge trigger mode

In global reset edge trigger mode, the global reset is made by the edge (rising/falling edge) of the trigger signal input to the camera. At the same time, global exposure is started, and the readout is made by normal readout mode. The timing, other than reset, is the same as the edge trigger mode.

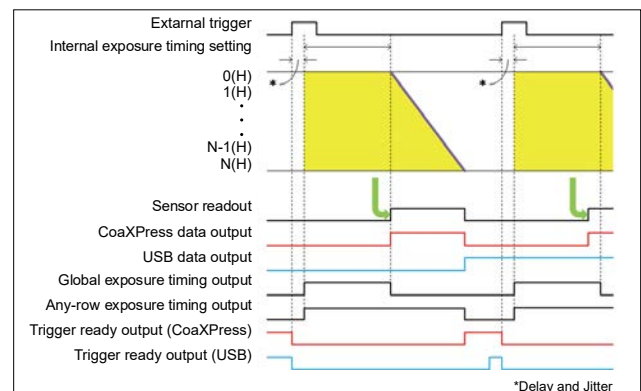

Fig. 8-7. Global reset edge mode

8-3-2-3. Level trigger mode

Level trigger mode is used when performing exposure in synchronization with an external trigger signal and externally controlling the exposure time with a trigger signal. The level trigger mode is a mode where the exposure starts when the input trigger signal switches from low to high (or high to low), and continues until the end of the period of high (or low). An example of the “high” trigger level is shown below. When the trigger signal goes to high, the exposure of the top row (0 H) starts, then after the readout time of one row, exposure of the next row starts, after which each row successively starts exposure. The exposure of the first row stops at the moment the signal level goes to low to start the readout of the signal. The exposure time of each row is the time from when the trigger level goes to high until it goes to low.

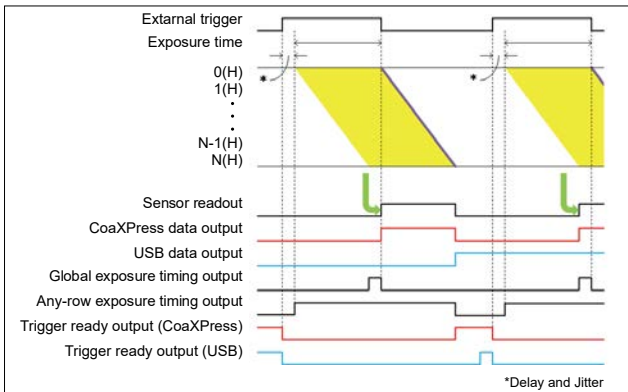

Fig. 8-8. Level trigger mode

8-3-2-4. Global reset level trigger mode

In global reset, the level trigger mode is a mode where the global reset is performed and exposure is started when the input trigger signal switches from low to high (or high to low), and the exposure continues until the end of the period of high (or low). As with the edge trigger mode, the readout is done by normal readout mode. The timing, other than the reset, is the same as the level trigger mode.

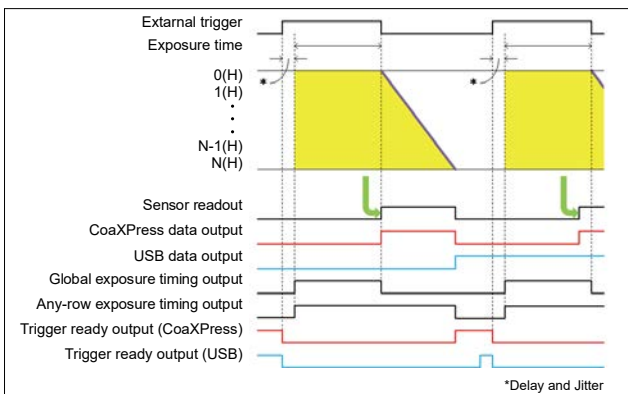

Fig. 8-9. Global reset level trigger mode

8-3-2-5. Synchronous readout trigger mode

In synchronous readout trigger mode, both the exposure end and readout start of the camera are made by the edge (rising/falling edge) of the trigger signal input to the camera. Both the next exposure end and next readout start of the camera are done by the next edge of the trigger signal input to the camera. That is, the exposure time will be the interval between the edges of an external trigger.

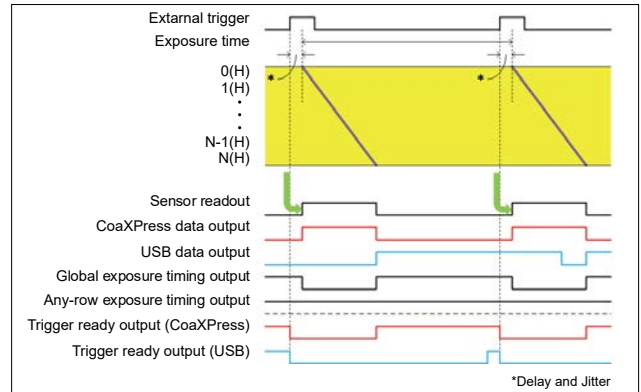

Fig. 8-10. Synchronous readout trigger mode (rising edge)

8-3-2-6. Trigger times

Trigger times is a function that allows the number of enabled triggers to be reduced by the ratio of the times number selected. For example, if the trigger time is four, three trigger inputs are ignored, and the next trigger input is enabled.

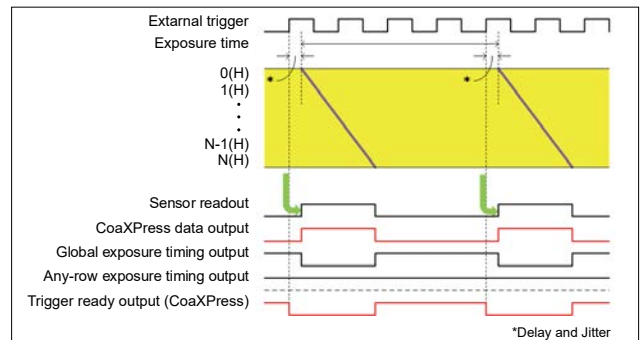

Fig. 8-11. Synchronous readout trigger mode (pulse count)

8-3-2-7. Start trigger mode

Start trigger mode captures continuous images with one external trigger pulse, by switching the camera operation to free running mode. It is capable of operating at the fastest frame rate. The exposure of the first frame is synchronized to the external input trigger (rising/falling edge).

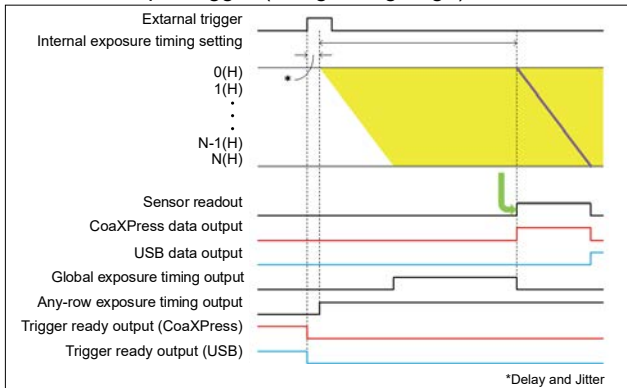

Fig. 8-12. Start trigger mode (rising edge)

8-4. Light sheet mode

8-4-1. Free running mode

As with the normal area mode, this allows the exposure time to be set using the software and is equipped with a free running mode that operates within the camera. In free running mode, the exposure time, readout slope (line interval) and readout direction can be set by the software. In the top to bottom readout, exposure is performed from row 0 H of the sensor top to 2303 H in 2 H increments. When the exposure ends, readout continues sequentially from row 0 H. The readout slope is used for synchronizing the readout timing in rows with the light beam scan speed.

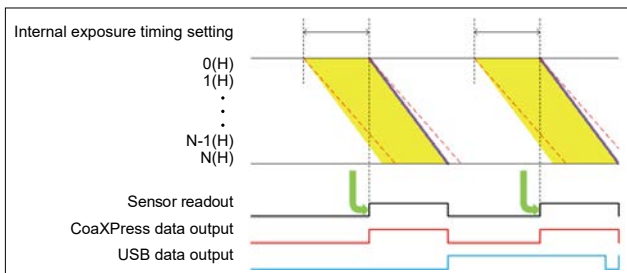

Fig. 8-13. Free running mode (top to bottom readout)

8-4-2. Edge trigger mode

In edge trigger mode, exposure is made sequentially from 0 H by the edge (rising/falling edge) of the trigger signal input to the camera. When the exposure ends, readout is performed by each row.

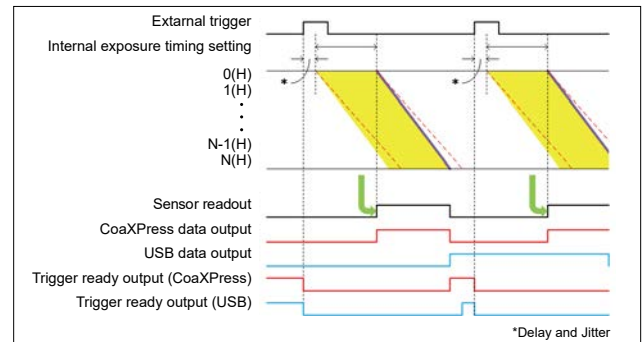

Fig. 8-14. Edge trigger mode (top to bottom readout)

8-4-3. Start trigger mode

The start trigger mode is used when controlling the timing for externally starting the image capture as with the normal area mode. In the start trigger mode, the exposure of the camera is started at the same time as the camera is switched to the free running by the edge (rising/falling edge) of the trigger signal input to the camera.

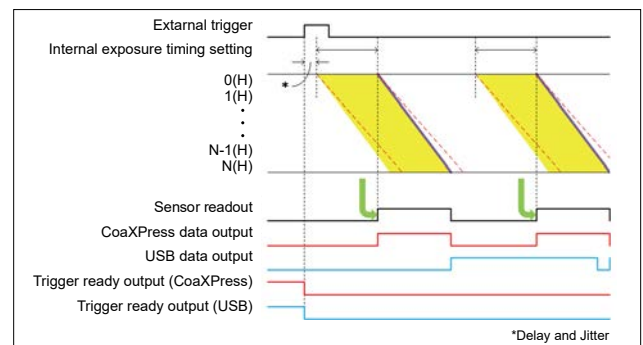

Fig. 8-15. Start trigger mode (top to bottom readout)

9. Understanding SNR

9-1. SNR

No single technical specification can provide all the information needed to match a camera to an application. However when quantum efficiency and noise characteristics of a camera are considered in light of the signal and signal noise, we can understand the theoretical limits of a camera under the full range of light conditions. The signal to noise ratio (SNR) provides tremendous value in predicting which camera performs best for certain applications, assuming the light levels for that application are known.

SNR is defined as the ratio of the total signal to the total noise. SNRs including EM-CCDs are calculated with Equation 9-1. In the equation, QE is quantum efficiency (%/100), S is input photon number (photons/pixel), Fn is the excess noise factor (EM-CCD Fn=1.4, others Fn=1), Ib is background (photons/pixel), Nr is readout noise (electron rms), M is the multiplication gain of EM-CCD (M=1 for CCD or sCMOS). The equation omits the dark current and also applies when the dark current is much smaller than the signal or background such as a short exposure time. For more detailed info please see our [ORCA®-Flash4.0 White Paper](#).

$$SNR = \frac{QE \times S}{\sqrt{F_n^2 \times QE \times (S + I_b) + (N_r/M)^2}}$$

Equation 9-1. Equation of SNR

9-2. rSNR

To make SNR data even more approachable, a useful variation is to look at relative SNR (rSNR), where all data is normalized to an imaginary “perfect camera” that has 100 % QE and zero readout noise.

With this transformation, it is easy to see that at all light levels which are 0.1 photons per pixel or higher with 0 background, the ORCA®-Quest has better SNR than EM-CCDs. Especially at light levels below 3 photons per pixel, the ORCA®-Quest delivers the best SNR of all sCMOS cameras.

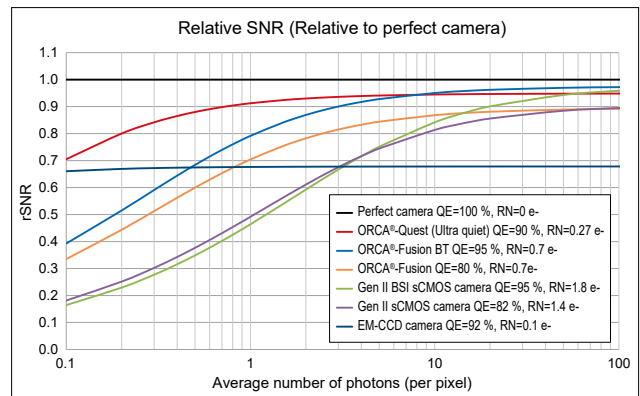

Fig. 9-1. Relative SNRs of various cameras

9-3. Camera Simulation Engine

To help to easily understand SNR, a “Camera Simulation Engine” is available in our website, please see the following link:

https://camera.hamamatsu.com/all/en/camera_simulation_engine/index.html

This engine can produce simulation images by selecting the parameters of QE, readout noise, dark noise, excess noise, exposure time, input photon numbers, etc. The images are made by calculating signal and noises that are based on an SNR equation. It provides a easy to follow, visual SNR comparison of many cameras.

10. Application Examples

10-1. Quantum technology (Neutral atom, Ion trap)

Neutral atoms and ions can be regarded as so-called qubits because they can take on a superposition state in which even a single atom has multiple properties. This property is being actively investigated to realize quantum computing and quantum simulation. Observing the fluorescence from trapped ions and neutral atoms with a low-noise camera is often used for determining the state of the qubit.

Fig. 10-1. shows a simulated image example of Rb atoms. Twenty-five Rb atoms are positioned in a 5×5 array with $5 \mu\text{m}$ distance each. In this simulation, each atom is the source for 2000 photons at 780 nm and is imaged by a $20\times$ (NA: 0.4) objective onto an ORCA[®]-Quest pixel array, with an added 5 photons/pixel background signal.

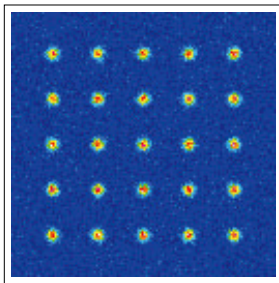

Fig. 10-1. A simulated image example of neutral atoms

10-2. Astronomy (Lucky / Speckle imaging)

When observing stars from the ground, it is very hard to capture clear star images with long exposure because the images are blurred by atmospheric turbulence. In contrast, clear images are sometimes captured with short exposure when those exposures match with atmospheric conditions. Lucky imaging is a method of acquiring a large stack of images. It then uses a subset of these images which have the least amount of atmospheric turbulence, shifts the brightest points to the same reference position and then averages the subset together to make a higher resolution image.

Fig. 10-2. shows an example image of Orion Nebula captured by lucky imaging with 3 color filters.



Fig. 10-2. Lucky imaging of Orion Nebula

10-3. Life science (Delayed fluorescence of plants)

Plants release a very small portion of the absorbed light energy, through photosynthesis, as photons over a long time. This phenomenon is known as delayed fluorescence. Detecting those photons makes it possible to observe the effects of chemicals, pathogens, the environment, and other stress factors on plants.

Fig. 10-3. shows a delayed fluorescence example of ornamental plants. The image is taken with 10 s exposure after 10 s has passed from when the excitation light is turned off.



Fig. 10-3. Plant photon (delayed fluorescence)

10-4. Raman spectroscopy

Raman effect is a scattering of light, the wavelength of which is shifted away from that of the incident light, and Raman spectroscopy is a technique for determining the material properties by measuring this wavelength shift. Raman spectroscopy enables structural analysis at the molecular level, which provides information on chemical bonding, crystallinity, etc.

Fig. 10-4. shows an example of a Raman effect image and the resulting spectrum for acetone. Since Raman scattering is very weak, low noise cameras are necessary for detecting. In addition, since the wavelength shift is small, high resolution and large pixel numbers are necessary for this application.

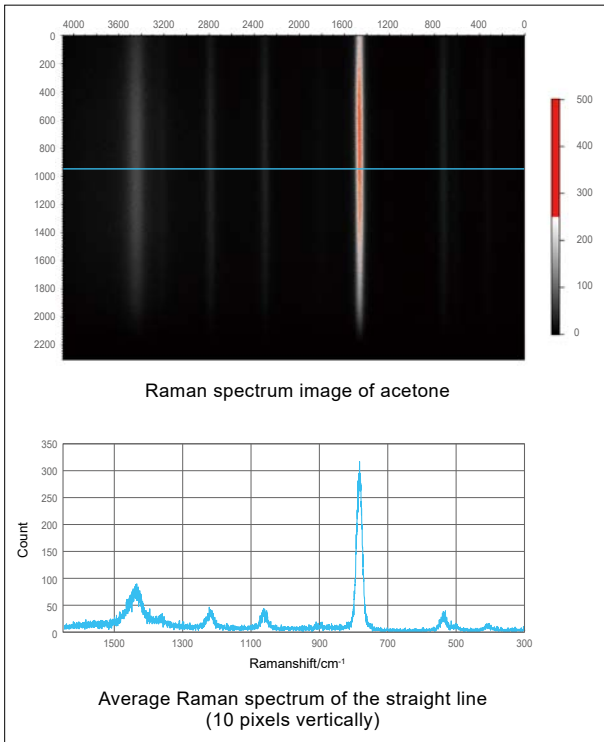

Fig. 10-4. An example of Raman spectrum

11. Specifications

11-1. Specification chart

Product number	C15550-20UP	
Imaging device	qCMOS® image sensor	
Effective number of pixels	4096 (H) × 2304 (V)	
Pixel size	4.6 μm (H) × 4.6 μm (V)	
Effective area	18.841 mm (H) × 10.598 mm (V)	
Quantum efficiency	90 % (peak QE)	
Full well capacity (typ.)	7000 electrons	
Readout noise (typ.)	Standard scan	0.43 electrons rms
	Ultra quiet scan	0.27 electrons rms
Dynamic range (typ.) ¹⁾	25 900 : 1	
Linearity error	EMVA 1288 standard (typ.)	0.5 %

Cooling method (Peltier cooling)	Sensor temperature	Dark current (typ.)
Forced-air cooled (Ambient temperature: +25 °C)	-20 °C	0.016 electrons/pixel/s
Water cooled (Water temperature: +25 °C)	-20 °C	0.016 electrons/pixel/s
Water cooled (max cooling)	Less than -35 °C ²⁾	0.006 electrons/pixel/s

Frame rate	CoaXPress		USB 3.1 Gen 1
Frame rate at full resolution	Standard scan	120 frames/s	17.6 frames/s
	Ultra quiet scan	5 frames/s	5 frames/s

Modes		
Sensor mode	Area readout	
	Lightsheet readout ³⁾	
	Photon number resolving	
Readout mode	Full resolution	
	Digital binning (2×2, 4×4)	
	Sub-array	

Digital output		
Digital output	16 bit / 12 bit / 8 bit	
Exposure time	Standard scan	7.2 μs to 1800 s
	Ultra quiet scan	172.8 μs to 1800 s
Interface	USB 3.1 Gen 1, CoaXPress (Quad CXP-6)	
Lens mount	C-mount	
Master pulse	Pulse mode	Free running / Start trigger / Burst
	Pulse interval	5 μs to 10 s in 1 μs steps
	Burst count	1 to 65 535
Image processing function	Defect pixel correction (ON or OFF, hot pixel correction 3 steps)	
Power supply	AC100 V to AC240 V, 50 Hz/60 Hz	
Power consumption	Approx. 155 VA	
Ambient operating temperature	0 °C to +40 °C	
Ambient operating humidity	30 % to 80 % (With no condensation)	
Ambient storage temperature	-10 °C to +50 °C	
Ambient storage humidity	90 % Max. (With no condensation)	

11. Specifications

Trigger input		
External trigger input mode	Area readout, Photon number resolving	Edge / Global reset edge / Level / Global reset level / Sync readout / Start
	Lightsheet readout	Edge / Start
Software trigger function	Area readout, Photon number resolving	Edge trigger / Global reset edge trigger / Start trigger
	Lightsheet readout	Edge trigger / Start trigger
Trigger input connector		SMA
Trigger delay function		0 s to 10 s in 1 μ s steps

Trigger output	
Trigger output	Global exposure timing output / Any-row exposure timing output / Trigger ready output / 3 programmable timing outputs / High output / Low output
Trigger output connector	SMA

*1: Calculated from the ratio of the full well capacity and the readout noise in Ultra quiet scan

*2: The water temperature is +20 °C and the ambient temperature is +20 °C

*3: Software such as HCImage is required. For details, please contact your local Hamamatsu representative or distributor.

11-2. Dimensional Outlines

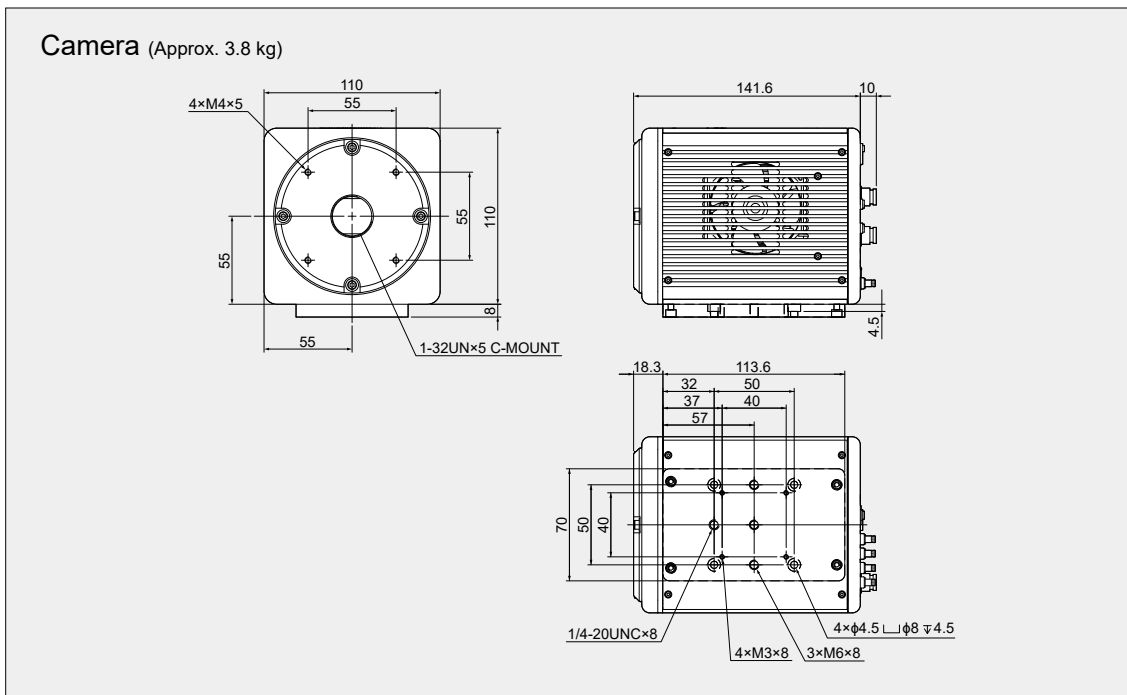

Fig. 11-1. Dimensional outlines

11-3. System Configuration

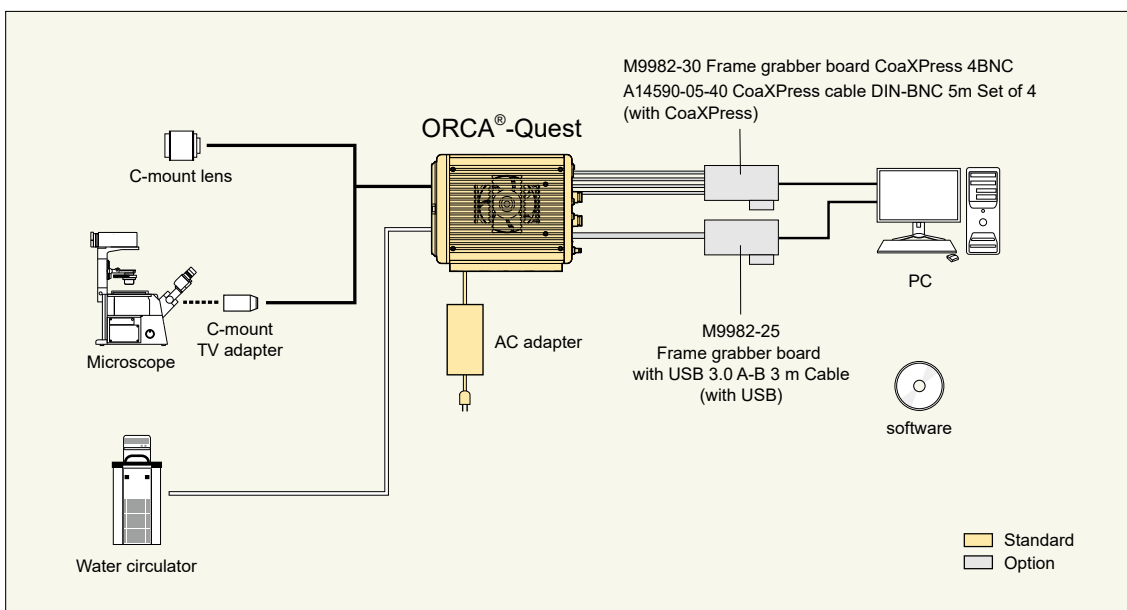

Fig. 11-2. Configuration example

11-4. Options

Product number	Product name
M9982-30	Frame grabber board CoaXPress 4BNC
A14590-05-40	CoaXPress cable DIN-BNC 5 m Set of 4
M9982-25	Frame grabber board with USB 3.0 A-B 3 m Cable
A12106-05	External trigger cable SMA-BNC 5 m
A12107-05	External trigger cable SMA-SMA 5 m

- ORCA is registered trademark of Hamamatsu Photonics K.K. (China, France, Germany, Japan, U.K., U.S.A.)
- qCMOS is registered trademark of Hamamatsu Photonics K.K. (EU, U.K.)
- Product and software package names noted in this documentation are trademarks or registered trademarks of their respective manufacturers.
- Subject to local technical requirements and regulations, availability of products included in this promotional material may vary. Please consult your local sales representative.
- Information furnished by HAMAMATSU is believed to be reliable. However, no responsibility is assumed for possible inaccuracies or omissions. Specifications and external appearance are subject to change without notice.

© 2021 Hamamatsu Photonics K.K.

HAMAMATSU PHOTONICS K.K. www.hamamatsu.com

Systems Division

812 Joko-cho, Higashi-ku, Hamamatsu City, 431-3196, Japan, Telephone: (81)53-431-0124, Fax: (81)53-433-8031, E-mail: export@sys.hpk.co.jp

U.S.A.: Hamamatsu Corporation: 360 Foothill Road, Bridgewater, NJ 08807, U.S.A., Telephone: (1)908-231-0960, Fax: (1)908-231-1218 E-mail: usa@hamamatsu.com

Germany: Hamamatsu Photonics Deutschland GmbH.: Arzbergerstr. 10, D-82211 Herrsching am Ammersee, Germany, Telephone: (49)8152-375-0, Fax: (49)8152-265-8 E-mail: info@hamamatsu.de

France: Hamamatsu Photonics France S.A.R.L.: 19, Rue du Saule Trapu, Parc du Moulin de Massy, 91882 Massy Cedex, France, Telephone: (33)1 69 53 71 00, Fax: (33)1 69 53 71 10 E-mail: infos@hamamatsu.fr

United Kingdom: Hamamatsu Photonics UK Limited: 2 Howard Court, 10 Tewin Road, Welwyn Garden City, Hertfordshire AL7 1BW, UK, Telephone: (44)1707-294888, Fax: (44)1707-325777 E-mail: info@hamamatsu.co.uk

North Europe: Hamamatsu Photonics Norden AB: Torshamnsgatan 35 16440 Kista, Sweden, Telephone: (46)8-509 031 00, Fax: (46)8-509 031 01 E-mail: info@hamamatsu.se

Italy: Hamamatsu Photonics Italia S.r.l.: Strada della Moia, 1 int. 6, 20044 Arese (Milano), Italy, Telephone: (39)02-93 58 17 33, Fax: (39)02-93 58 17 41 E-mail: info@hamamatsu.it

China: Hamamatsu Photonics (China) Co., Ltd.: 1201 Tower B, Jiaming Center, 27 Dongsanhuan Beilu, Chaoyang District, 100020 Beijing, P.R. China, Telephone: (86)10-6586-6006, Fax: (86)10-6586-2866 E-mail: hpc@hamamatsu.com.cn

Taiwan: Hamamatsu Photonics Taiwan Co., Ltd.: 8F-3, No.158, Section 2, Gongdao 5th Road, East District, Hsinchu, 300, Taiwan R.O.C. Telephone: (886)3-659-0080, Fax: (886)3-659-0081 E-mail: info@hamamatsu.com.tw

Cat. No. SCAS0154E01
MAY/2021 CR
Created in Japan