



C13015-01

For CMOS linear image sensor S11639-01, etc.

The C13015-01 is a driver circuit developed for Hamamatsu CMOS linear image sensor S11639-01, etc. By connecting the C13015-01 to a PC through the USB 2.0 interface, you can control the C13015-01 from the PC and acquire 16-bit digital output numeric data converted from the sensor's analog video signal. The C13015-01 consists of a sensor circuit board that drives the sensor and an interface circuit board that drives the sensor circuit board and performs data communication with the PC. The two circuit boards are connected via a flexible cable. The sensor circuit board is compact, making it easy to be installed in optical systems. The interface circuit board has an external trigger I/O connectors that can be used to synchronize with external devices. This product comes with application software (DcIc-USB) that runs on Microsoft® Windows® 10 (32-bit, 64-bit). It can be used to easily control the C13015-01 from the PC. The product also includes a DLL that the user can use to create original C13015-01 control programs.

Features

- Built-in 16-bit A/D converter
- Compact sensor circuit board: Easy to install in optical systems
- Interface: USB 2.0
- External synchronization capable
- Single power supply: USB bus powered (+5 VDC)

Note) Microsoft and Windows are either registered trademarks or trademarks of Microsoft Corporation in the United States and/or other countries.

Application

- Spectrometers
- CMOS linear image sensor S11639-01, etc. control and data acquisition

The C13015-01 is compatible with the following CMOS linear image sensor. Note that the C13015-01 does not include a sensor.

Type no.	Number of pixels	Number of effective pixels	Pixel size (μm)	Image size [mm (H) × mm (V)]	Package
S11639-01	2048	2048	14 × 200	28.672 × 0.200	LCP (liquid crystal polymer)
S11639-11		2004		28.056 × 0.200	LCP
S11639-21*1		2048		28.672 × 0.200	Surface mount type ceramic
S15739-1024	1024	1024	14 × 200	14.336 × 0.200	LCP
S15739-1024-20*1		1024		14.336 × 0.200	Surface mount type ceramic
S15796-1024*2	1024	1024	7 × 200	7.168 × 0.200	LCP
S15796-1024-20*1		1024		7.168 × 0.200	Surface mount type ceramic
S15796-2048		2048		14.366 × 0.200	LCP
S15796-2048-20*1	2048	2048		14.366 × 0.200	Surface mount type ceramic
S13496	4096	4096	7 × 200	28.672 × 0.200	LCP
S13496-11		4008		28.056 × 0.200	LCP
S13496-20*1		4096		28.672 × 0.200	Surface mount type ceramic
S12706		4096		28.672 × 0.007	LCP

*1: A conversion board is needed when using in combination with the surface mount ceramic type. Contact us for detailed information.

*2: A conversion board is needed when using the S15796-1024. Contact us for detailed information.

Structure

Parameter	Specification	Unit
Output type	Digital	-
A/D resolution	16	bit
Interface	USB 2.0	-

➤ Absolute maximum ratings

Parameter	Symbol	Condition	Value	Unit
Supply voltage	Vdd	Ta=25 °C	0 to +6.0	V
Input signal voltage*3	Vi	Ta=25 °C	0 to +Vdd	V
Operating temperature	Topr	No dew condensation*4	0 to +50	°C
Storage temperature	Tstg	No dew condensation*4	-20 to +70	°C

*3: Trigger input

*4: When there is a temperature difference between a product and the surrounding area in high humidity environment, dew condensation may occur on the product surface. Dew condensation on the product may cause deterioration in characteristics and reliability.

Note: Exceeding the absolute maximum ratings even momentarily may cause a drop in product quality. Always be sure to use the product within the absolute maximum ratings.

➤ Electrical characteristics (Ta=25 °C)

Parameter	Symbol	Condition	Min.	Typ.	Max.	Unit
Readout frequency	fop		-	10	-	MHz
Conversion gain	Gc	Gain=1	-	31	-	μV/ADU
Trigger output voltage	High level	Vdd=+5 V	3.8	-	Vdd	V
	Low level		-	-	0.6	V
Trigger input voltage	High level	Vdd=+5 V	+3.5	-	Vdd	V
	Low level		-	-	1.5	V
Current consumption	Ic		-	300	500	mA
High start pulse period*5 *6	thp(ST)		10	-	tpi(ST) - 200	clocks*7

➤ Electrical and optical characteristics (Ta=25 °C)

■ When mounted with S11639-01/-11/-21 (2048 pixels)

Parameter	Symbol	Min.	Typ.	Max.	Unit
Readout noise	Nread	-	14	-	ADU rms
Saturation output	Dsat	-	56000	65535	ADU
Dynamic range*8	DR	-	4000	-	-
Line rate*9	-	-	-	4	kHz
Start pulse period*5 *10	tpi(ST)	2500	-	4294967295	clocks*7

■ When mounted with S15739-1024/-1024-20 (1024 pixels)

Parameter	Symbol	Min.	Typ.	Max.	Unit
Readout noise	Nread	-	14	-	ADU rms
Saturation output	Dsat	-	56000	65535	ADU
Dynamic range*8	DR	-	4000	-	-
Line rate*9	-	-	-	6.6	kHz
Start pulse period*5 *10	tpi(ST)	1500	-	4294967295	clocks*7

■ When mounted with S15796-1024/-1024-20 (1024 pixels)

Parameter	Symbol	Min.	Typ.	Max.	Unit
Readout noise	Nread	-	14	-	ADU rms
Saturation output	Dsat	-	56000	65535	ADU
Dynamic range*8	DR	-	4000	-	-
Line rate*9	-	-	-	6.6	kHz
Start pulse period*5 *10	tpi(ST)	1500	-	4294967295	clocks*7

*5: $thp(ST) < tpi(ST)$

*6: A maximum value exists when the synchronization mode is internal mode, external edge mode, or external gate mode.

*7: 1 clock = 1/fop

*8: $DR = Dsat/Nread$

*9: Theoretical line rate value determined by the internal operation timing of the driver circuit. This is different from the line rate defined in the sensor specifications. This is also different from the rate (system rate) in a series of processes that acquire data into the PC via the USB 2.0 port.

*10: A maximum value exists when the synchronization mode is internal mode or external gate mode.

■ When mounted with S15796-2048/-2048-20 (2048 pixels)

Parameter	Symbol	Min.	Typ.	Max.	Unit
Readout noise	Nread	-	14	-	ADU rms
Saturation output	Dsat	-	56000	65535	ADU
Dynamic range*11	DR	-	4000	-	-
Line rate*12	-	-	-	4	kHz
Start pulse period*13 *14	tpi(ST)	2500	-	4294967295	clocks*15

■ When mounted with S13496/-20 or S13496-11 (4096 pixels)

Parameter	Symbol	Min.	Typ.	Max.	Unit
Readout noise	Nread	-	16	-	ADU rms
Saturation output	Dsat	-	58300	-	ADU
Dynamic range*11	DR	-	3600	-	-
Line rate*12	-	-	-	2.2	kHz
Start pulse period*13 *14	tpi(ST)	4500	-	4294967295	clocks*15

■ When mounted with S12706 (4096 pixels)

Parameter	Symbol	Min.	Typ.	Max.	Unit
Readout noise	Nread	-	33	-	ADU rms
Saturation output	Dsat	-	55700	-	ADU
Dynamic range*11	DR	-	1700	-	-
Line rate*12	-	-	-	2.2	kHz
Start pulse period*13 *14	tpi(ST)	4500	-	4294967295	clocks*15

*11: DR = Dsat/Nread

*12: Theoretical line rate value determined by the internal operation timing of the driver circuit. This is different from the line rate defined in the sensor specifications. This is also different from the rate (system rate) in a series of processes that acquire data into the PC via the USB 2.0 port.

*13: thp(ST) < tpi(ST)

*14: A maximum value exists when the synchronization mode is internal mode or external gate mode.

*15: 1 clock = 1/fop

Functions

Function	Description
Trigger mode change	The following trigger modes are available. For the detailed timing of each mode, see "Trigger mode" in "Timing chart" (P.4). <ul style="list-style-type: none"> · Internal mode · External edge mode · External level mode · External gate mode
Gain adjustment	The gain can be set to a value between 1 and 6 with a 6-bit number ranging from 0 to 63. The preset gain is calculated by the following equation. The default gain is 1. $\text{Gain} = \frac{6}{1 + 5 \left(\frac{63 - G}{63} \right)}$ G: 6-bit value
Offset adjustment	The offset can be set in the range of -255 to +255. The offset increment per step is approximately 1.2 mV. The offset is set by writing a 9-bit value to the C13015-01 internal register. If the most significant bit (MSB) of the 9-bit value is zero, the offset is positive. Otherwise, the offset is negative. The bit values other than the MSB are the magnitude of the offset. Note that because the offset circuit is arranged before the amplifier stage, the actual offset is equal to the offset value set above × gain.
Integration time change	The sensor integration time is changed by changing the high period of the ST pulse.
Start pulse period change	A maximum value exists for internal mode or external gate mode.

Block diagram

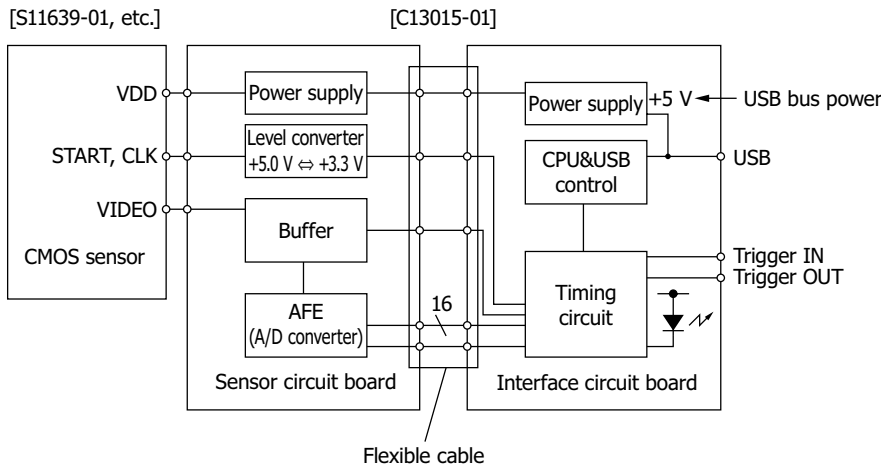

KACCC0807EA

Timing chart

Sensor drive timing

The two parameters that can be changed in the sensor drive timing are the ST pulse width $thp(ST)$ and the line period $tpi(ST)$. For the $thp(ST)$ and $tpi(ST)$ setting ranges in internal mode, external edge mode, and external gate mode (explained later), see "Electrical characteristics" (P.2, 3). The timings of T1, T2, and T3 when the S11639-01 is connected are as follows.

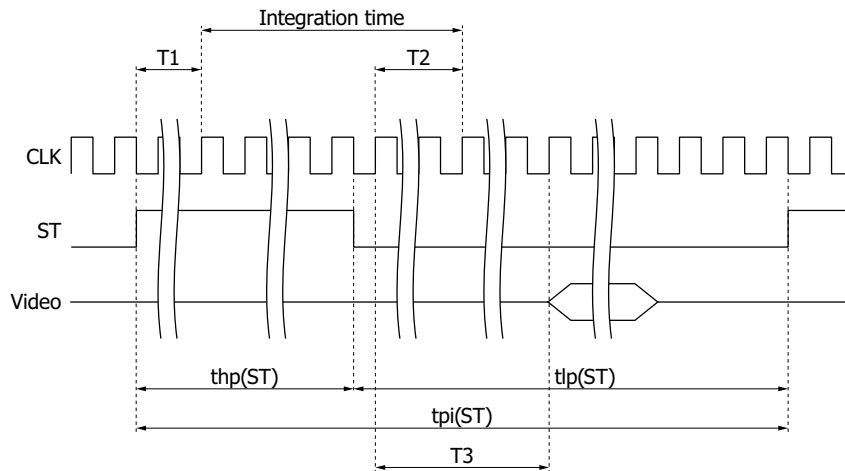

KACCC0780EA

- T1=4CLK
- T2=52CLK
- T3=87CLK
- (1CLK=0.1 μs)
- Integration time= $thp(ST) + 48CLK$

The following condition must be met.
 $tpi(ST) > thp(ST)$

Trigger mode

■ Internal mode

When a Start command is received from the PC, the C13015-01 starts sensor integration and outputs acquired image data.

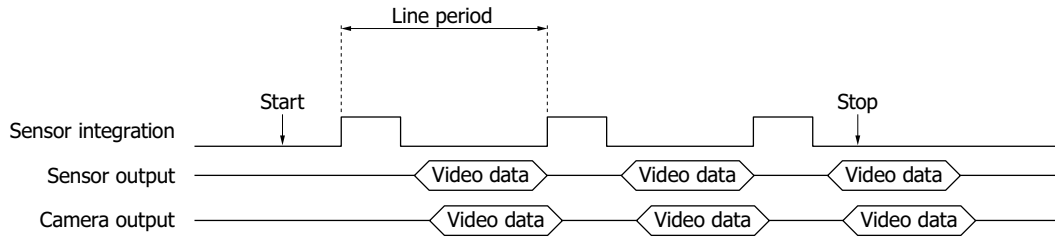

KACCC0775EA

■ External edge mode

The sensor integration is synchronized to the edges of an external input trigger signal. When the circuit receives an external trigger after having received a Start command, the circuit sends the image data output from the sensor to the PC.

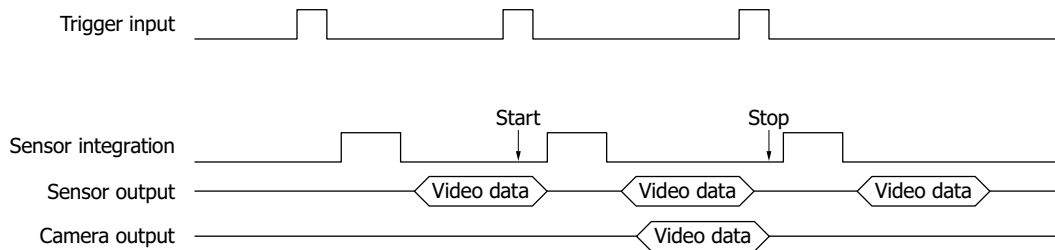

KACCC0776EA

■ External level mode

Integration time and line transmission period are controlled using an external trigger signal.

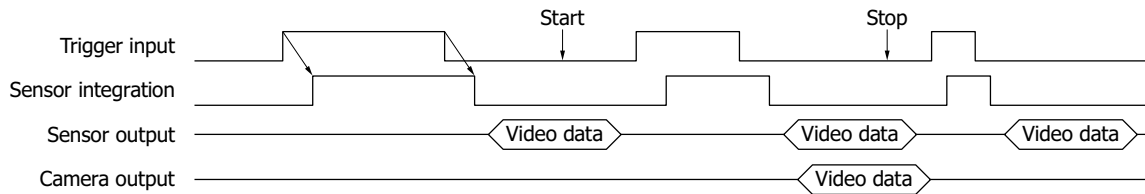

KACCC0777EA

■ External gate mode

Integration is performed only while the external trigger is valid.

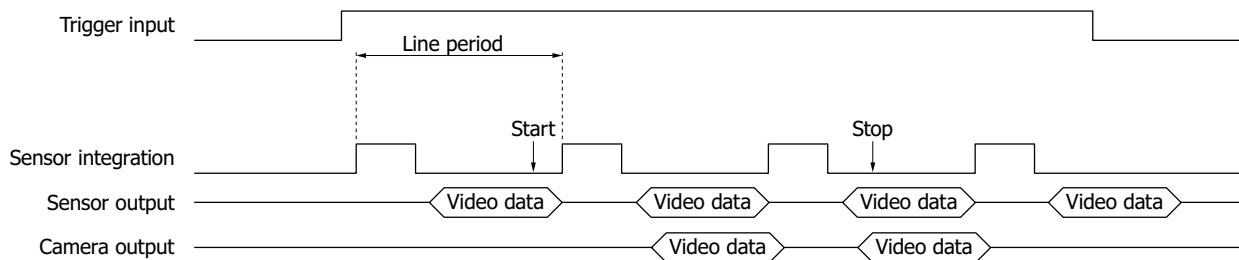

KACCC0778EA

Dimensional outline (unit: mm)

■ Sensor circuit board

[Sensor attachment side]

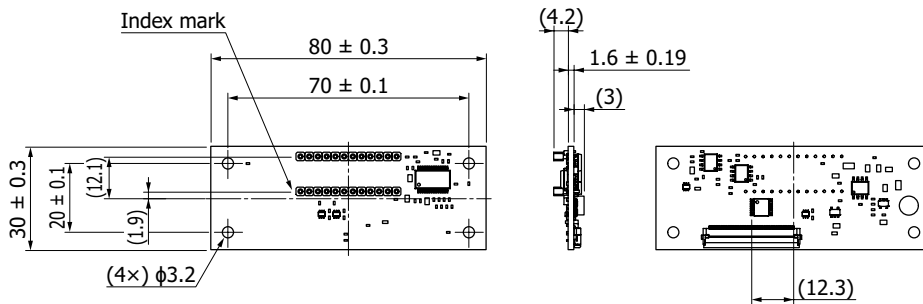

■ Interface circuit board

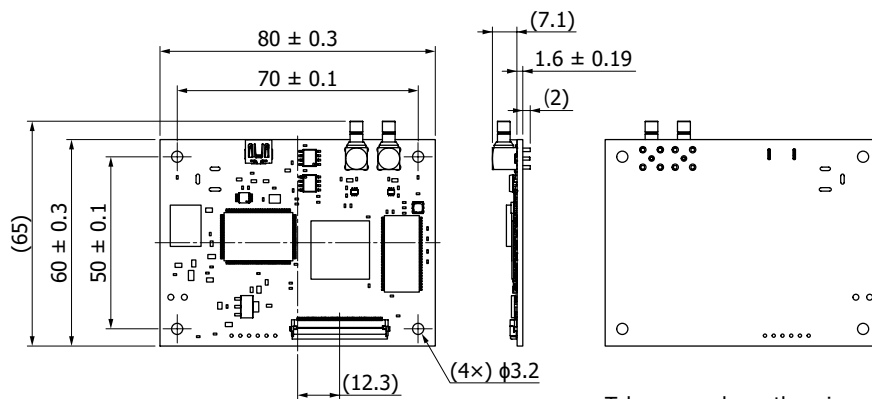

Tolerance unless otherwise noted complies with JIS B 0408-B.

KACCA0373EA

Weight: approx. 40 g (including the flexible cable but not the sensor)

Connection example

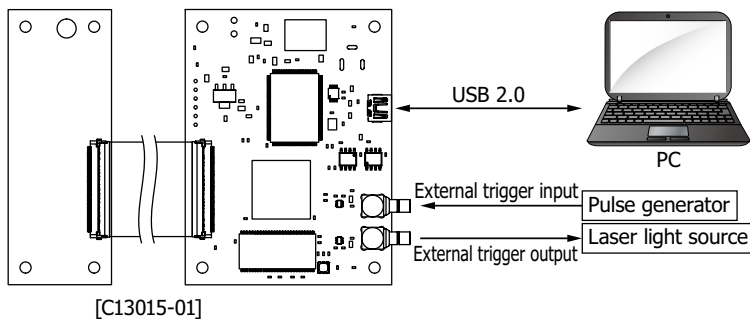

KACCC0808EA

Accessories

- CD-ROM (includes the instruction manual, application software, and DLL file)
- USB (Mini B) cable
- Flexible cable for connecting sensor circuit board and interface circuit board (length: 100 mm)

Related information

www.hamamatsu.com/sp/ssd/doc_en.html

- Precautions
 - Disclaimer
 - Image sensor

Information described in this material is current as of April 2022.

Product specifications are subject to change without prior notice due to improvements or other reasons. This document has been carefully prepared and the information contained is believed to be accurate. In rare cases, however, there may be inaccuracies such as text errors. Before using these products, always contact us for the delivery specification sheet to check the latest specifications.

The product warranty is valid for one year after delivery and is limited to product repair or replacement for defects discovered and reported to us within that one year period. However, even if within the warranty period we accept absolutely no liability for any loss caused by natural disasters or improper product use. Copying or reprinting the contents described in this material in whole or in part is prohibited without our prior permission.

HAMAMATSU

www.hamamatsu.com

HAMAMATSU PHOTONICS K.K., Solid State Division

1126-1 Ichino-cho, Higashi-ku, Hamamatsu City, 435-8558 Japan, Telephone: (81)53-434-3311, Fax: (81)53-434-5184

U.S.A.: HAMAMATSU CORPORATION: 360 Foothill Road, Bridgewater, NJ 08807, U.S.A., Telephone: (1)908-231-0960, Fax: (1)908-231-1218 E-mail: usa@hamamatsu.com

Germany: HAMAMATSU PHOTONICS DEUTSCHLAND GMBH.: Arzbergerstr. 10, 82211 Herrsching am Ammersee, Germany, Telephone: (49)8152-375-0, Fax: (49)8152-265-8 E-mail: info@hamamatsu.de

France: HAMAMATSU PHOTONICS FRANCE S.A.R.L.: 19, Rue du Saule Trapu, Parc du Moulin de Massy, 91882 Massy Cedex, France, Telephone: (33)1 69 53 71 00, Fax: (33)1 69 53 71 10 E-mail: infos@hamamatsu.fr

United Kingdom: HAMAMATSU PHOTONICS UK LIMITED: 2 Howard Court, 10 Tewin Road, Welwyn Garden City, Hertfordshire AL7 1BW, UK, Telephone: (44)1707-294888, Fax: (44)1707-325777 E-mail: info@hamamatsu.co.uk

North Europe: HAMAMATSU PHOTONICS NORDEN AB: Torshamnsgatan 35 16440 Kista, Sweden, Telephone: (46)8-509 031 00, Fax: (46)8-509 031 01 E-mail: info@hamamatsu.se

Italy: HAMAMATSU PHOTONICS ITALIA S.R.L.: Strada della Moia, 1 int. 6, 20044 Arese (Milano), Italy, Telephone: (39)02-93 58 17 33, Fax: (39)02-93 58 17 41 E-mail: info@hamamatsu.it

China: HAMAMATSU PHOTONICS (CHINA) CO., LTD.: 1201 Tower B, Jiaming Center, 27 Dongsanhuan Beilu, Chaoyang District, 100020 Beijing, P.R. China, Telephone: (86)10-6586-6006, Fax: (86)10-6586-2866 E-mail: hpc@hamamatsu.com.cn

Taiwan: HAMAMATSU PHOTONICS TAIWAN CO., LTD.: 8F-3, No.158, Section 2, Gongdao 5th Road, East District, Hsinchu, 300, Taiwan R.O.C. Telephone: (886)3-659-0080, Fax: (886)3-659-0081 E-mail: info@hamamatsu.com.tw